



# TESTING MACHINE TOOLS

By

DR. GEORG SCHLESINGER

Seventh Edition  
(Second Impression)

Revised by  
F. KOENIGSBERGER  
D.Sc., Dipl.-Ing., M.I.Mech.E.

For the use of Machine Tool Makers,  
Users, Inspectors and Plant Engineers

# TESTING MACHINE TOOLS

For the use of Machine Tool Makers,  
Users, Inspectors and Plant Engineers

By

DR. GEORG SCHLESINGER

Seventh Edition  
(Second Printing)

Revised by  
F. KOENIGSBERGER  
D.Sc., Dipl.-Ing., M.I.Mech.E.

---

With 44 Inspection Charts

---



THE MACHINERY PUBLISHING CO., LTD.

*Head Office:* NEW ENGLAND HOUSE, NEW ENGLAND STREET, BRIGHTON, 1

*Registered Office:* CLIFTON HOUSE, 83-117, EUSTON ROAD, LONDON, N.W.1

*Distributors for the U.S.A.:*

THE INDUSTRIAL PRESS, 93, WORTH STREET, NEW YORK, 10013, N.Y.

WHEELS INDIA LTD.

10 JAN 1977

PADI, MADRAS-600050.

WHEELS INDIA LIMITED

Plant Eng. & Eng. Dept

Date: 19.1.77

First Published ("Inspection Tests on Machine Tools")	1932
Second Edition ("Testing Machine Tools") .. .. .	1938
Third Edition .. .. .	1940
Fourth Edition .. .. .	1945
Fifth Edition .. .. .	1949
Fifth Edition (Second Printing) .. .. .	1951
Fifth Edition (Third Printing) .. .. .	1954
Sixth Edition .. .. .	1961
Seventh Edition .. .. .	1966
Seventh Edition (Second Printing) .. .. .	1970

© THE MACHINERY PUBLISHING CO., LTD.

*All rights of reproduction reserved by the Publishers by virtue of the Universal Copyright and International Copyright (Brussels and Berne) Conventions and throughout the World.*

Printed in Great Britain by  
The Whitefriars Press Ltd.,  
London and Tonbridge

## Preface to the Seventh Edition

THE original German Edition of the "Prüfbuch für Werkzeugmaschinen" as well as its translations in many languages have been intimately connected with the personality of the author. In 1901 Schlesinger started the work of establishing acceptance standards for machine tools, and in 1927 he published for the first time a comprehensive series of acceptance test specifications for machine tools. Today this work has been carried on both in the national and international field, and after several countries have developed national standards it would appear that agreement on an international basis will be reached in the not too distant future.

Schlesinger himself was a great believer in the importance of international standardisation, and before the Second World War he was an active member of the I.S.A. Committee 39 (now Committee I.S.O./TC39, Machine Tools). It is to be hoped that this work will soon lead to the publication of I.S.O. standards.

Nevertheless, the continuing demand for Schlesinger's book would appear to indicate the need for a further edition. This, however, is not intended to compete in any way with the I.S.O. or any other standards but should serve as a complementary publication in which Schlesinger's ideas of specifying and executing acceptance tests are shown in their logical development. For this reason the work of revising the Fifth Edition was concentrated on the introductory text, pages 1-44, and especially on those points which appeared to have given rise to doubts or misunderstanding, rather than on modification of the actual Test Charts. Changes in the latter were introduced only if either errors or difficulties in the application of existing specifications had been reported to the undersigned.

No attempt has been made to adapt the form or contents of the Test Charts in any way to existing national or international standards. Such an adaptation would be of little if any value; if acceptance tests in accordance with definite standards are specified by a supplier or a customer, only the latest issue of the appropriate standard specification must be employed for carrying out the tests. As, however, most existing standard specifications appear to be based on ideas laid down in the original Schlesinger Test Charts, the discussion of the basic principles and the explanation of testing procedures retain their general value. The new edition is intended to continue the tradition of previous editions to the effect that it should not only assist in teaching the beginner but also advise the more experienced test engineer when he encounters problems outside his field of experience.

Mention may be made of a discrepancy between the English and German versions of

Test Chart 13, Figs. 8A, 8B and 11A. If these are compared and reference is also made to previous editions, the following will be found:

Edition	Fig. 8A	Fig. 8B	Fig. 11A
First (1932) .. ..	0 to 0.01 per 300 mm.	0 to 0.01 per 300 mm.	0 to 0.01 per 300 mm.
Second (1938) and following	0 to 0.01 per 300 mm.	0 to 0.005 per 300 mm.	0 to 0.01 per 300 mm.

In the German version, these tolerances were as follows:

Edition	Fig. 8A	Fig. 8B	Fig. 11A
First (1927) .. ..	0 to 0.01 per 300 mm.	0 to 0.01 per 300 mm.	0 to 0.01 per 300 mm.
Second (1931) .. ..	0 to 0.01 per 300 mm.	0 to 0.01 per 300 mm.	0 to 0.01 per 300 mm.
Third (1939) .. ..	0 to 0.02 per 300 mm.	0 to 0.01 per 300 mm.	0 to 0.02 per 300 mm.
Fourth (1949) .. ..	0 to 0.02 per 300 mm.	0 to 0.01 per 300 mm.	0 to 0.02 per 300 mm.
Fifth (1951) .. ..	0 to 0.02 per 300 mm.	0 to 0.01 per 300 mm.	0 to 0.02 per 300 mm.

From the above it would appear that Schlesinger left the tolerances for Figs. 8A and 11A in the English version and halved the tolerances for Fig. 8B, probably at the request of British manufacturers. On the other hand, in 1939, *i.e.* one year later, the tolerances for Figs. 8A and 11A in the German version were increased, probably at the request of the German industry. It would seem, therefore, that Schlesinger had a definite reason for increasing the tolerances in the German version. However, the undersigned has advised the publishers of the German version to bring the tolerances in the German version in line with the English version if this appears desirable.

The undersigned is grateful to the many firms who assisted him by critical comments on previous editions. They appear to indicate that even today, over 30 years after the publication of the First Edition, the Schlesinger standards are still widely and satisfactorily used.

Finally, the undersigned would like to express his thanks to his friend and colleague, Dr. J. H. Lambie, for reading through the script.

F. KOENIGSBERGER.

# Index to Contents

	PAGE		PAGE
Introduction .. .. .	5	18a. Multi-spindle Automatics (Rotary Work and Stationary Tools) .. .. .	63
Principles of Acceptance Tests .. .. .	5	18b. Multi-spindle Automatics (Stationary Work and Rotary Tools) .. .. .	65
The Machine Tool under Load .. .. .	6	19. Vertical Boring Mills (Vertical Lathes) .. .. .	66
Execution of Acceptance Tests .. .. .	7	20. Double-standard Vertical Boring Mills .. .. .	68
Measuring Equipment and Methods:		GRINDING MACHINES (21-26)	
Dial Gauges .. .. .	8	21. Cylindrical Grinding Machines .. .. .	70
Test Mandrels .. .. .	9	22. Planer-type Surface Grinders .. .. .	71
Straight-edges and Squares .. .. .	10	23. Vertical Surface Grinders .. .. .	72
Spirit Levels .. .. .	10	24. Surface Grinders with Horizontal Wheel Axis .. .. .	73
Level Measurement by Water Level .. .. .	12	25. Surface Grinders with Vertically Adjustable Horizontal Wheel Spindle .. .. .	74
Alignment by Wire and Measuring Microscope .. .. .	13	26. Universal Tool and Cutter Grinders .. .. .	75
Alignment by Telescope and Target .. .. .	13	DRILLING AND HORIZONTAL BORING MACHINES (31-38)	
Magnitude and Direction of Tolerances .. .. .	14	31. Upright Drilling Machines .. .. .	76
Straightness of Slideways and Flatness of Tables .. .. .	14	32. Pillar Type Drilling Machines .. .. .	77
Alignment and True Running of Shafts .. .. .	16	33. Multi-spindle Drilling Machines .. .. .	78
Lead or Pitch Error of Lead-screws .. .. .	17	34. Radial Drilling Machines .. .. .	79
Pitch Errors of Gears and Dividing Errors of Dividing Heads .. .. .	19	35. Horizontal Boring Machines with Spindles up to 80 mm. (about 3 $\frac{1}{8}$ in.) diameter .. .. .	81
Details for Testing Various Machine Tools .. .. .	20	36. Horizontal Boring Machines with Spindles more than 80 mm. (about 3 $\frac{1}{8}$ in.) diameter .. .. .	82
Surface Quality .. .. .	44	37. Horizontal Boring Machines with Adjustable Columns .. .. .	82
Power Requirements, Speeds and Feeds .. .. .	44	38. Horizontal Boring Machines with Fixed Headstocks .. .. .	83
MILLING MACHINES (1-4) AND GEAR CUTTING MACHINES (6-7)		PLANING, SHAPING, AND SLOTTING MACHINES (41-44)	
1. Knee-type Horizontal Milling Machines and Universal Milling Machines .. .. .	45	41. Planing Machines (Double Standard) .. .. .	84
1a. Dividing Heads .. .. .	46	42. Opside Planing Machines .. .. .	85
2. Surface Milling Machines .. .. .	47	43. Shaping Machines .. .. .	87
3. Vertical Milling Machines .. .. .	48	44. Slotting Machines .. .. .	88
4. Thread Milling Machines .. .. .	49	SHEARING, PUNCHING, STAMPING MACHINES AND PRESSES (51-53)	
6. Spur, Worm and Helical Gear-hobbing Machines .. .. .	50	51. Open-fronted Power Presses and Punching Machines .. .. .	89
7. Gear Shapers .. .. .	52	52. Double Standard Power Presses and Punching Machines .. .. .	90
CENTRE LATHES, TURRET LATHES, MULTI-SPINDLE AUTOMATICS, VERTICAL BORING MILLS (11-20)		53. Shearing Machines and Guillotines .. .. .	90
11. Finish Turning Lathes up to 400 mm. (about 15 $\frac{1}{2}$ in.) Height of Centres .. .. .	54	WOODWORKING MACHINES (61-70)	
12. Finish Turning Lathes with from 400 to 800 mm. (about 15 $\frac{1}{2}$ in. to 32 in.) Height of Centres .. .. .	55	61. Circular Saws, Edging Saws, Cross Cutting and Trenching Machines .. .. .	91
13. Tool-room Lathes (highest degree of accuracy) up to 200 mm. (about 8 in.) Height of Centres .. .. .	56	62. Band Saws .. .. .	92
14. Backing-off or Relieving Lathes .. .. .	57	63. Fret Saws .. .. .	93
15. Facing Lathes .. .. .	58	64. Frame Saws, Multi-blade .. .. .	93
16. Turret Lathes arranged for Cylindrical Tool Shanks in the Turret Heads, and Single-spindle Automatic Turret Lathes up to 300 mm. (about 12 in.) Height of Centres .. .. .	60	65. Surface Planing Machines .. .. .	94
16a. Turret Lathes with Hollow Turret Heads provided with Centring Recesses for Tool Holders up to 300 mm. (about 12 in.) Height of Centres .. .. .	61	66. Thicknessing Machines .. .. .	94
17. Turret Lathes arranged of Cylindrical Tool Shanks in the Turret Heads and Single-spindle Automatic Turret Lathes with more than 300 mm. (12 in.) Height of Centres .. .. .	62	67. 4-Cutter Planing and Moulding Machines .. .. .	95
17a. Turret Lathes with Hollow Turret Heads provided with Centring Recesses. Height of Centres more than 300 mm. (12 in.) .. .. .	63	68. Vertical Spindle Moulders .. .. .	95
		69. Chain Mortising Machines .. .. .	96
		70. Wood Turning Lathes .. .. .	96

# INTRODUCTION

THE instructions for the inspection and testing of machine tools specified in this book are intended to serve as a basis for acceptance tests of high-quality machine tools. The experience of machine-tool manufacturers and users has been used in their compilation. Although the instructions were originally intended only for application to new machines, they have also been successfully used for the testing of reconditioned machine tools and for general maintenance work.

## Closer Tolerances than those Specified

Machine tools which satisfy the accuracies specified in this book will produce components which will meet the requirements of modern production in accordance with standard limits and fits. If, however, closer tolerances are needed, these can only be obtained by expensive additional operations and tedious selective assembly.

This may be the case, for example, if special lead-screws

for lathes or dividing heads for milling and grinding machines are to be produced. Such requirements, which are necessary only in exceptional cases, will result in additional cost.

## Wider Tolerances than those Specified

For the manufacture of components to medium or coarse tolerances, the use of the high-precision machine tools covered by this book may not be necessary. In such cases wider tolerances, which may exceed the limits specified in this book by 50 or even 150 per cent in accordance with the machining accuracy required, may be permissible. This widening of tolerances will, however, not apply to all values specified in the test charts. It would then be necessary, therefore, for manufacturers and purchasers to come to a detailed agreement on the tolerance values prior to a purchasing contract being signed, as the price of the machine will, of course, depend on the arrangements made.

## PRINCIPLES OF ACCEPTANCE TESTS

### Where and How the Tests are to be carried out

In general, the tests should be carried out at the manufacturer's works. It is hardly possible for the machine-tool manufacturer to assume the responsibility for the consequences of treatment to which machine tools are subjected whilst being transported from the works to their destination. Machine tools are very sensitive to impact or shock; even heavy castings are not always solid and rigid enough to withstand stresses caused by a fall during transportation, which may result in deformations and possibly cracks, thereby rendering the entire machine useless.

Moreover, the machine is always carefully adjusted and aligned during assembly or on the test stand at the manufacturer's works, whereas experience has shown that erection in the workshop of the user is not always carried out with sufficient care. Sometimes, for reasons of economy, particularly in the case of heavy machines, foundations are made too light and are not extended to a sufficient depth. Faulty erection may cause working inaccuracies which may then wrongly be blamed on the machine.

Also, at the manufacturer's plant, skilled men are available together with the necessary testing equipment, which is only obtainable with difficulty outside the testing department.

Obviously, the purchaser of a machine is fully entitled to repeat the tests in his own works, but if it is his intention to do so he should have at his disposal all the necessary testing equipment and an experienced inspection staff. The manufacturer's test chart, a copy of which is supplied to the buyer, should serve as a guarantee that the machine has been tested in the manufacturer's works under precisely the conditions (on a concrete foundation or cast-iron base plate) under which it will later have to work. As a rule cast-iron base plates are unsuitable for heavy machines because they cannot be provided with access openings which may often be required. On the other hand, it is undesirable to install expensive permanent foundations which may have to be removed at a later date.

In the event of any complaint, the manufacturer can refer to his own test records, and insist that in the user's plant the same conditions are established as those under which the machine was originally tested. Tests carried out by the user are to be regarded merely as a confirmation of the results supplied by the manufacturer.

THE PRECISION TESTS COVER THE GRADE OF ACCURACY OF THE MACHINE TOOL ITSELF, AND, WHENEVER FEASIBLE, ALSO ITS WORKING ACCURACY. Primarily, the degree of the manufacturing accuracy of the machine tool itself is to be tested, *i.e.* the accuracy with which the machine has been assembled. This is measured while the machine is idle and free of any load.

In the majority of cases, working limits to be attained with the machine in operation are specified at the end of the test charts. These apply to finishing operations only. A finishing cut on a lathe, for example, has been defined as one producing a chip of about 0.1 to 0.2 millimetre (0.004 to 0.008 inch) depth and 0.05 to 0.1 millimetre (0.002 to 0.004 inch) feed, taken with the highest speed which is permissible for the material of the workpiece and the tool. The resulting machined surface must be smooth and without chatter marks which would indicate inadmissible vibration.

During such cutting tests the various surfaces of the machine cannot be kept free from coolant, swarf and chips, and these tests should be carried out before the final painting operations. In cases where, in view of high costs, because of the lack of the necessary foundation for heavy machines or for other reasons, it is not practicable to carry out cutting operations, the degree of working accuracy may be "assured" or "promised".

The manufacturing accuracy of the machine and the accuracy of the finished workpiece are interconnected. When a machine tool is assembled from components which have been machined to gauges, the unavoidable machining errors have to be adjusted during assembly in such a manner that the finished machine tool will produce workpieces within the required limits. The accuracy performance of the machine is specified at the end of each

chart. Recommended procedures for testing the working accuracy of lathes, milling, grinding and drilling machines are given on page 42 *et seq.*

The author considers it wrong to draw a dividing line between practical and geometrical tests. The so-called practical tests check the accuracy of the finished component, whilst the geometrical tests cover the manufacturing accuracy of the machine. Both measurements are practical and both form part of one indivisible whole. Neither the user nor the manufacturer can dispense with either of these tests. The reason for giving prominence to the manufacturing accuracy of the machine in the test procedure lies in the fact that it covers the whole machine and can be carried out unambiguously and without difficulty. The cutting tests can only be carried out for random sizes and conditions, for otherwise the time necessary for their execution and their costs would be prohibitive.

The degree of working accuracy of the machine, besides depending on the machine itself, is also influenced by such other factors as:

1. The type of cutting tool and its condition (rake angles, hardness, eccentricity in the case of milling cutters, etc.);
2. The tool holder (*e.g.* milling arbors);
3. The cutting speed, feed and chip section;
4. The material to be machined;
5. The shape, size and rigidity of the workpiece;
6. The chucking or clamping equipment;
7. The skill of the operator.

It is, therefore, not always practicable to guarantee the obtainable degree of working accuracy. Limited or conditional "assurances" or "promises", not binding in law, frequently can only be given to the effect that the machine, when properly erected and applied in conformity with its design and when proper tools are used, will meet the specified degrees of working accuracies.

In the case of the *lathe*, the cutting tests cover mainly the turning of cylindrical parts and the cutting of screw threads close to the headstock. This procedure is adopted whether short or very long machines are being tested. As the latter may have to be used over their full length, even a number of random cutting tests would not give sufficient guarantee for their accuracy at any part of the bed. It is still more difficult to check the screw-cutting accuracy over the full length of the machine, in order to make certain that accurate screw threads can be cut in spite of possible errors in the spindle, the feed drive, the lead-screws, the slideways, etc. The test of the accuracy with which the machine has been manufactured covers, however, every point of the machine over its full length.

In the case of *milling machines*, the factors previously stated have as much influence as the quality of the machine itself, and promises concerning the degree of working accuracy can only be made with certain reservations. Nevertheless, reputable milling-machine manufacturers test their machines very thoroughly, using a large variety of tools and different workpiece materials before starting a full programme of production.

*Planing machines* are often used for the machining of castings which may not be free of internal stresses and which are liable to possible deformation caused by excessive clamping forces. In order to achieve the working accuracies

obtainable on the machines, special precautions have to be taken. The method by which internal stresses of castings are relieved and the way in which a cast workpiece is clamped to the machine table may greatly affect the accuracy of the planing operation. In order to eliminate such sources of error which may have a greater influence than the manufacturing inaccuracy of the machine itself, the workpiece is replaced by a straight-edge. This represents a stress-free workpiece. A precision dial gauge clamped to the tool is guided over its top edge thus replacing the planing tool (see Fig. 7, page 13).

### The Machine Tool Under Load

Deformations and vibrations are created in the frames and other parts of the machine tool during machining operations. In spite of considerable research work done in this field, tests which cover the vibration behaviour of any machine tool are difficult for the following reasons:

1. The deformations of beds and other main members of the machine tool are not easy to calculate because the sections are usually complicated and the textbook conditions for beam calculations rarely apply. Only actual measurements of deformations caused under various loading conditions can make up for the lack of accurate calculations, and results of such measurements are still scarce.

2. The stresses and deformations which are due to finishing cuts taken on small and medium-size machine tools are very small and, therefore, difficult to measure, especially in an ordinary machine shop where changes of temperature, sources of vibration and the lack of suitable skilled testing staff may affect the accuracy of the results. Stresses and distortions greater than those specified for the precision tests would, of course, occur during roughing cuts, and machine tools are employed for roughing as well as for finishing operations. However, the permissible stresses caused by roughing cuts are limited only by the consideration that permanent deformation must not be caused even after several years of continual use. Moreover, it is the final result of the finishing operation which determines the accuracy performance of a machine, and only finishing tests are therefore essential, the result of the roughing operation being of little importance as regards accuracy and surface finish.

With regard to vibrations, various investigations concerning the causes and elimination of chatter on different machine tools have been carried out.\* Some of them serve for determining the conditions under which a machine tool can be used without the danger of chatter, others serve for the testing and improving of newly designed and prototype machines. As far as acceptance tests for standard machines rather than prototypes are concerned, it is suggested that, for the time being, finishing cuts be still taken for determining the performance of the machine. This method reveals not only the geometrical accuracy of the shape produced, but also the quality of surface finish, the tests being at once simple and severe. It must be remembered that sometimes the high cost of testing a machine must be borne by the user, and it would appear that for an ordinary good quality machine tool it is sufficient to carry out a finishing test on a workpiece specified by the user and accepted by the supplier of the machine.

In the case of machines intended for roughing operations

\* See the publications by S. A. Tobias in Great Britain, and by J. Tlustý in Czechoslovakia.



only, the specified rate of metal removal obtainable without undue noise, deformation and vibration should be tested. The performance, as far as power requirements, load transmission, etc., are concerned, depends mainly on the design, and design faults cannot be corrected by the best workmanship during manufacture. Any company manufacturing machines, no matter how accurately produced, which do not provide the required performance, will soon be eliminated from the market. The standard of accuracy depends on the quality of the manufacturer's workshop, on the equipment used, and on the craftsmen on the job. This has to be tested on each machine as purchased, and errors found can be corrected when necessary.

#### Layout of Test Charts

A short text in the charts describes each test, the charts being arranged in such a manner that at first the manufacturing accuracy of the machine is tested, and then the accuracy of its performance. Each test is further explained by a sketch in which the method of measurement is also indicated. In the third column of the charts the values of the permissible errors are specified.

#### Execution of Acceptance Tests

##### 1. *Levelling the Machine before Starting the Test*

Before any tests are started, the machines must be carefully levelled by means of a precision spirit level. The correct installation of a machine is the basis for any test. No design can be such as to prevent deformations beyond permissible tolerances if an upright, a bed or a frame is put down wrongly on its foundation. Spirit levels must be placed on finished (scraped, ground or finish-planed) surfaces only.

##### 2. *Zero Lines*

Zero lines are only to be used for general setting purposes. High precision setting and aligning measurements should be carried out solely by means of a dial gauge or an equivalent instrument.

##### 3. *Auxiliary Equipment*

Any auxiliary testing equipment required which may have to suit particular machines, has to be provided at the manufacturer's works.

##### 4. *Substitution of a Testing Procedure by an Equivalent Method*

If the instruments shown in the test chart are not available, they may be substituted by others as long as these are equivalent. It may be necessary to calibrate such alternative instruments for the occasion.

##### 5. *Testing of Special-purpose Machines*

Special-purpose machines which differ from standard machines, and are, therefore, not covered by the test charts must be tested by a reasonable application of the principle rather than the letter of the test specifications.

##### 6. *Conversion of Tolerances from One Reference Length to Another*

In the case of very small machines, it is often impossible or impracticable to refer errors to the basic lengths stated in the test charts, *i.e.* 1,000 millimetres (approximately

40 inches); 300 millimetres (approximately 12 inches) or 100 millimetres (approximately 4 inches). For example, on an automatic lathe which has a working length of 65 millimetres ( $2\frac{1}{2}$  inches), the permissible error must not be reduced exactly *pro rata* in relation to the reference length, because this would result in a permissible tolerance for directional measurement below 0.01 millimetres (0.0004 inch), and such is never required except for precision tool-room lathes and grinding machines where tolerances of half this value, *i.e.* 0.005 millimetres (0.0002 inches) are specified.

##### 7. *Testing of the Assembled Machine*

The machine is to be tested in its fully assembled state, and should, therefore, not be dismantled during the tests. No machine is improved by being taken to pieces. Many machine parts are assembled by force or driving fits, and considerable force would have to be applied for separating such parts. This dismantling could damage a machine which otherwise would have worked satisfactorily for many years. In addition, dismantling and re-assembling operations are time-consuming and expensive. The acceptance tests are not intended for inspecting the machine components separately. These have to be within the manufacturing tolerances which are essential in quality production. The final accuracy of the assembled machine is, however, the result of the most suitable combination of the tolerances permitted in the manufacture of the individual components, this being effected in such a manner that errors do not become cumulative in any sub-assembly or in the final assembly. The acceptance tests check only the final result of the whole assembly and not the manufacturing accuracy of each single component.

##### 8. *Avoiding Time-wasting Measurements*

Every endeavour has been made to avoid as far as possible measurements which would take excessive time. When these appear essential, the manufacturer's guarantee may be accepted to the effect that such measurements, for instance, the pitch accuracy of lead-screws or the dividing accuracy of master wheels for gear-cutting machines, are within the required limits. As the manufacturer has to carry out the appropriate tests before assembling the machine, the customer should accept a record of these tests. After all, the manufacturer cannot be expected to carry out such expensive tests more than once.

##### 9. *Testing Main Spindles after the Trial Run*

Precision tests of the main spindles should be carried out only on the conclusion of the trial run of the machine. The spindles are then running at their working temperatures and have taken up their normal position in the bearings. This condition is usually reached when the machine has been running for about 30 to 60 minutes.

##### 10. *Influence of Clearances in Bearings and Slideways*

In the case of high-speed machines, *e.g.* machines using tungsten carbide or diamond tools, or machines for the machining of light alloys, or in the case of machines with wide speed ranges, the clearances in bearings and slideways have often to be relatively large and, consequently, can cause difficulties during high-precision alignment measurements. Such measurements should then be carried out at the normal running temperature of the machines, *i.e.* after the machine has been running for about one hour. If necessary, adjustments of bearings or slideways may be

carried out during the test. This difficulty need not be considered if spindles run in pre-loaded ball and roller bearings.

### 11. Axial (or End) Play and Axial Slip of a Spindle

End play is caused by the natural and indispensable freedom of movement of a spindle in an axial direction. This is necessary to prevent seizing when the spindle is warming up. Such end play must not be too small, especially in the case of high-speed machines, e.g. grinders and machines for light alloys, and it must be uniform over the full circumference of the bearing. Axial slip, on the other hand, is an undesirable axial movement which occurs periodically with each revolution and is caused by manufacturing errors, for instance, by lack of parallelism of thrust-ring faces, irregularities in ball races or similar causes. It is only this axial slip caused by manufacturing errors which has to be tested, and which has to be kept within the specified tolerances.

### 12. Working Instructions

Apart from the specified tolerances, certain common-sense rules must be maintained and observed during the

acceptance tests. Bearings must be adjusted so that their temperatures do not exceed the required limits. Gears must be axially in line and run noiselessly, pulleys and belts must satisfy the requirements of smooth driving conditions at the correct speeds, etc. No separate specifications have been laid down for these conditions as they have to be observed on every high-quality machine.

### 13. Test Run

Each machine is normally subjected to a test run before despatch. The user may be invited to witness this. It is, however, unreasonable of the purchaser to request a test run after the machine has already been prepared for despatch, i.e. when a test run is a practical impossibility.

### 14. Errors and Other Causes of Differences of Opinion

If these occur, the measuring instruments are first checked and, if necessary, the tests repeated with other instruments, or, better still, by means of another testing method. If different methods give the same answer, the results are confirmed, whilst different results indicate faults in the method or the instruments employed.

## MEASURING EQUIPMENT AND METHODS

Any type of equipment may be used as long as the specified measurement can be carried out with the required degree of accuracy.

The accuracy obtainable with a particular type of equipment employed must always be compared with the required accuracy of measurement. In addition, the influence of the human element, i.e. the personal error of each inspector, has to be allowed for. The accuracy in reading the micrometer depends on the personal touch of the inspector, but on the other hand, the interpretation of a spirit-level measurement should be independent of such influence.

### Dial Gauges

The graduation must be clear and normally need not be finer than 0.01 millimetre (0.0004 inch).

Finer graduations which are required in special cases should only be used if the measuring accuracy of the instrument justifies it. In such cases graduations down to  $1 \mu$  (0.00004 inch) may be used.

The initial plunger\* pressure should vary between 40 and 100 grammes (about 1.4 to 3.5 ounces); for very fine measurements a pressure as low as 20 grammes (0.7 ounce) is desirable.

Too low a spring pressure on the plunger may be a source of errors in the case of swing-over measurements (Fig. 1A) because in the upper position spring pressure and plunger weight will act in the same direction, whilst in the lower position they will be opposed to each other. For this reason either a sufficiently high spring pressure must be provided, or the measuring method replaced by another equivalent one. As an example, Figs. 1B and 1C show the measurement of the alignment between the bores of a cutter spindle and an arbor bearing in the outer stay of a surface-milling machine. Instead of a direct swing-over method, the position of the two axes is measured in relation

\* Although the makers of dial gauges refer always to a "spindle", the term "plunger" will be used throughout this text for the sake of clarity and the avoidance of confusion with the main spindle of a machine tool.

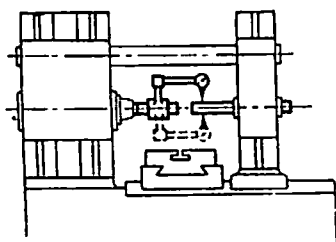

Fig. 1A

Fig. 1A. Example of Swing-over Measurement

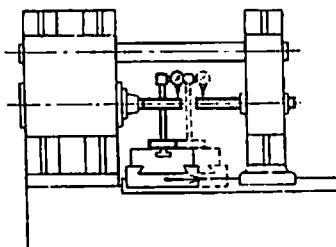

Fig. 1B

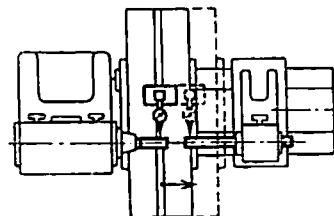

Fig. 1C

Fig. 1B and 1C. Position of the Two Axes is measured in Relation to Common Datum Planes

to common datum planes (provided by the bed slideways), the table movement being used for moving the dial gauge along the datum planes (see page 32).

The dial gauge must be fixed to robust and stiff bases and bars in order to avoid displacements due to shock or vibration. In order to ensure stability, the base should have a large locating surface. The vertical column should be a round steel bar or steel tube of about 16 to 25 millimetres ( $\frac{5}{8}$  to 1 inch) diameter; the supporting member should be a steel bar 10 to 16 millimetres ( $\frac{3}{8}$  to  $\frac{1}{2}$  inch) diameter.

Clamping nuts, etc., should be designed in such a manner that a positive hand grip is possible for tight clamping. Knurled nuts are not usually sufficient.

For trammel readings, the bar supporting the dial gauge must be rigid, a tapered rectangular bar or a steel tube being suitable.

### Test Mandrels

The most widely used inspection tool during manufacture and acceptance tests of new machine tools, and the repair of old ones, is the test mandrel, the quality of which (especially as far as straightness and roundness are concerned) is of paramount importance for accurate results. However, a factor, which must not be overlooked, is the "natural sag", i.e. the deflection caused by the weight of the mandrel. Sag occurs when the mandrel is fixed between centres, and is more marked when it is supported at one end only by the taper shank, with the outer end freely overhanging.

This sag is frequently not taken into consideration and may cause trouble and discussions which can be avoided when the characteristics of solid and hollow mandrels are known and considered in the interpretation of alignment tests, of which "axis to axis" (see Fig. 1A) and "axis to plane" (see Fig. 1B, 1c) are the most frequent examples.

Two types of test mandrel are used:

1. Mandrels with a cylindrical measuring surface and a taper shank which can be inserted into the taper bore of the main spindle;
2. Cylindrical mandrels which can be held between centres.

All mandrels must be hardened, stress-relieved and ground.

The measuring length of the cylindrical part of mandrels depends on their purpose. In the case of mandrels with taper shank it varies between 100 and 500 millimetres (4 to 20 inches). The diameter must be such that the sag is kept within permissible limits. In order to reduce the

weight of the mandrel, the author used hollow mandrels as long ago as 1902. Their dimensions and measured deflections under their own weight are shown in Figs. 2 and 3. Deflections caused by the spring pressure of the dial-gauge plunger are negligible if this pressure is less than  $3\frac{1}{2}$  ounces.

The centres should be counter-bored so that they are not easily damaged and can be used when the mandrels have to be tested for true running.

The taper bore of the spindle of an ordinary lathe must run true. The maximum permissible eccentric error is 0.03 millimetre measured at a distance of 300 millimetres (0.001 inch at a distance of 12 inches) (see Chart 11, Test 7, page 54). A still greater accuracy, 0.02 millimetre at a distance of 300 millimetres (0.0008 inch at a distance of 12 inches) is required for the parallelism between the spindle axis and the bed, both in the vertical and horizontal plane (see Chart 11, Test 8). For the toolroom lathe, the permissible error is only 0.01 millimetre per 300 millimetres (0.0004 inch per foot). Using a solid steel mandrel of 25 millimetres (1 inch) diameter and 300 millimetres (12 inches) long the natural sag is 0.0096 millimetre (0.00038 inch). This is too much, whereas the hollow mandrel of the same outside diameter has a sag of only 0.00305 millimetre (0.00012 inch), which is within permissible limits.

Before the alignment of a spindle axis is measured, the spindle must be tested for true running by means of the test mandrel inserted in the spindle taper bore. The spindle must then be turned into a position of mean eccentricity error, and if the alignment measurement is carried out in this mean position the influence of eccentric running is eliminated.

*Example:* Lathe spindle parallel with bed in the vertical plane (spindle rising towards the free end of mandrel only).

The tolerance is 0 to 0.02 millimetre (0 to 0.0008 inch) measured over a length of 300 millimetres (12 inches).

The spindle with a test mandrel inserted in its taper bore shows that during one revolution the mandrel axis varies

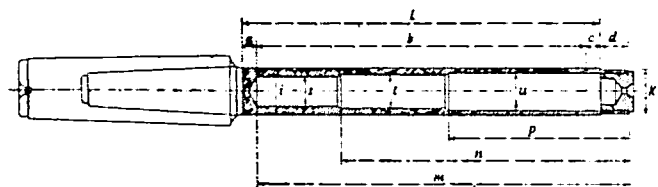

Fig. 2A. Hollow Test Mandrel with Taper Shank

Morse Taper <sup>o</sup> No.	External Cylinder (Inches)						Bore (Inches)					Total Length L	
	length				Outside Diam.		Depths		Diam. of Bore				
	a	b	c	d	i	k	m	n	p	s	t		u
†0	†1	2	$\frac{1}{16}$	4	$\frac{1}{16}$	$\frac{1}{8}$	—	—	—	—	—	—	5 $\frac{1}{2}$
†2	†3	4	$\frac{1}{16}$	8	$\frac{1}{16}$	1	—	9	6	—	$\frac{1}{8}$	$\frac{1}{8}$	9 $\frac{1}{2}$
†4	5	6	$\frac{1}{16}$	12	$\frac{1}{16}$	1 $\frac{1}{2}$	13 $\frac{1}{2}$	10	6 $\frac{1}{2}$	$\frac{1}{4}$	$\frac{1}{4}$	1 $\frac{1}{2}$	13 $\frac{1}{2}$
†5	6	—	$\frac{1}{16}$	20	$\frac{1}{16}$	1 $\frac{1}{2}$	21 $\frac{1}{2}$	16	10	1 $\frac{1}{2}$	1 $\frac{1}{2}$	2	21 $\frac{1}{2}$

\* The big diameter of the Morse Taper must be at least as big as the diameter  $\boxed{i}$  of the measuring cylinder. Use the † tapers only in emergency.

Fig. 2B. Dimensions of Hollow Mandrels.

its position from I to II as shown in Fig. 4. Before taking the alignment measurement, the spindle is, therefore, rotated into position 0, i.e. the mean position between I and II, and now the measurement of the parallelism between spindle axis and bed can be carried out.

### Straight-edges and Squares

Straight-edges of cast iron or steel should be heavy, well-ribbed and free of internal stresses. Their bearing surfaces should be as wide as possible. The error at the top of a standard square should be less than  $\pm 0.01$  millimetre ( $\pm 0.0004$  inch), of a precision square less than  $\pm 0.005$  millimetre ( $\pm 0.0002$  inch). A master square which would serve for checking squares in normal use is best made as a hardened steel cylinder, ground all over with the faces accurately square to the cylindrical surface. As such a master square is usually ground on a precision grinding machine an accuracy of  $\pm 0.002$  millimetre ( $\pm 0.00008$  inch) is obtainable. Master squares made of box sections are also useful. They are generally made of stress-free cast iron with all faces mutually square or parallel. If, for the purpose of some measurement, a

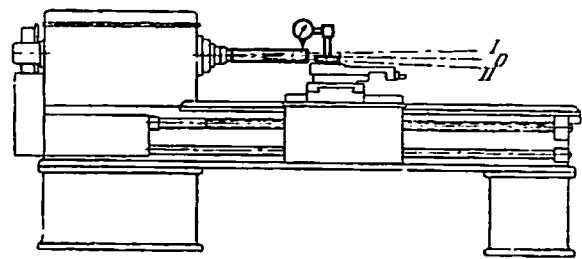

Fig. 4. Mandrel running out of Truth must be set to Mean Position before Testing for Parallelism with the Bed

dial gauge has to be traversed along the faces of a square, the use of a master cylinder or a box-sectioned square is easier and more reliable.

### Spirit Levels

Spirit levels are used in the shape of a bubble tube which is mounted on a cast-iron base. The two main types are the horizontal (see Fig. 12, page 14), and the frame spirit level (see Fig. 15, page 15). Spirit levels used for high-precision measurements (tolerances 0.02 to 0.04 millimetre per 1,000 millimetres, i.e. 0.00025 to 0.0005 inch per foot) should have a sensitivity of about 0.03 to 0.05 millimetre per 1,000 millimetres (0.0004 to 0.0006 inch per foot) for each division. A movement of the bubble by one division corresponds then to a change in slope of 6 to 12 seconds. If a level of 0.04 millimetre per 1,000 millimetres (0.0005 inch per foot) is chosen, then

- 1 division = 0.04 mm./1,000 mm. (0.0005 in./ft.);
- $\frac{2}{3}$  division = 0.03 mm./1,000 mm. (0.00035 in./ft.);
- $\frac{1}{2}$  division = 0.02 mm./1,000 mm. (0.00025 in./ft.);
- $\frac{1}{4}$  division = 0.01 mm./1,000 mm. (0.00015 in./ft.).

It is quite easy to estimate to within a quarter of a division, and agreement between two testing authorities (the manufacturer and user) is easier to reach than with estimates of  $\frac{1}{3}$  or  $\frac{1}{4}$  division. Spirit levels which are too sensitive are difficult to bring to rest in a workshop in which machines are running, while too low a sensitivity results in insufficient reading accuracy, as very small

Outside Diameter		Inside Diameter of Bore		Deflection	
mm.	inches	mm.	inches	$\mu$	inch
75	3	Solid	—	13.2	0.000519
80	3 $\frac{1}{8}$	—	—	11.6	0.000456
80	3 $\frac{1}{8}$	50	2	8.35	0.000329
80	3 $\frac{1}{8}$	60	2 $\frac{1}{2}$	7.45	0.000293
100	4	Solid	—	7.4	0.000291
100	4	60	2 $\frac{1}{2}$	5.5	0.000216
100	4	80	3 $\frac{1}{8}$	4.55	0.000179
125	5	Solid	—	4.75	0.000187
125	5	80	3 $\frac{1}{8}$	3.4	0.000133
125	5	100	4	2.9	0.000114

Fig. 3A Sag or Deflection of Cylindrical Mandrels, 1,000 mm. (40 inches) in Length, Held between Centres

No.	Outside diameter		Inside diameter		Total length		Measuring length (b)		Deflection at measuring position		Morse Taper No.	Biggest diameter of taper	
	in.	Appr. mm.	in.	Appr. mm.	in.	Appr. mm.	in.	Appr. mm.	in.	mm.		in.	mm.
1	$\frac{1}{2}$ (0.63)	16	Solid	Solid	5 $\frac{1}{2}$	148	5 $\frac{1}{2}$	130	0.0005	0.00125	*1 and 2	0.48 and 0.79	12.07 and 20.02
2a	1	25	Solid	Solid	9 $\frac{1}{2}$	250	9 $\frac{1}{2}$	230	0.0017	0.0043	*3 and 4	0.94 and 1.23	$\frac{1}{4}$ in. = 3 mm. thickness of wall
b	1	25	$\frac{1}{2}$ Solid	Solid	9 $\frac{1}{2}$	250	9 $\frac{1}{2}$	230	0.0012	0.00305			
c	1	25	Solid	Solid	12 $\frac{1}{2}$	315	11 $\frac{1}{2}$	295	0.0038	0.0096			
3a	1 $\frac{1}{2}$	40	Solid	Solid	14 $\frac{1}{2}$	375	13 $\frac{1}{2}$	350	0.0031	0.0078	5 and 6	1.75 and 2.5	$\frac{1}{4}$ in. = 3 mm. thickness of wall
b	1 $\frac{1}{2}$	40	1 $\frac{1}{2}$ Solid	Solid	14 $\frac{1}{2}$	375	13 $\frac{1}{2}$	350	0.0023	0.0058			
4a	2 $\frac{1}{2}$	62	Solid	Solid	21 $\frac{1}{2}$	555	20 $\frac{1}{2}$	525	0.0078	0.0198	6	2.5	63.35
b	2 $\frac{1}{2}$	62	Solid stepped bore (cf., Fig. 2)	Solid	21 $\frac{1}{2}$	555	20 $\frac{1}{2}$	525	0.0046	0.0116			

\* Avoid tapers 1 and 3 here, if possible, because the largest diameter of taper is smaller than the outside diameter of the cylindrical part.

Fig. 3B. Sag of Solid and Hollow Test Mandrels with Taper Shank and Cylindrical Bore (Constant Inside Diameter).

fractions of a division have to be estimated. The tolerance normally encountered in a good spirit level may be up to half a division; but, if possible, a tolerance of only a quarter of a division should be aimed at. For measuring tolerances ranging from 0.1 to 0.2 millimetre per 1,000 millimetres (0.00125 to 0.0025 inch per foot), spirit levels having a sensitivity of 0.1 to 0.3 millimetre per 1,000 millimetres (0.00125 to 0.00375 inch per foot) per division are suitable.

The bearing surfaces of spirit levels and Vee-blocks, as well as those of precision frame spirit levels, should be as long as possible. For testing medium-size machines they should be not less than 200 millimetres (about 8 inches) long. The supporting face is best interrupted in the middle. It is often advisable to use a bridge piece (see Fig. 6B, page 12) the feet of which are about 300 millimetres (12 inches) apart. The spirit level can then be placed on the scraped surface of the bridge. This method avoids errors which could be caused by irregular scraping of the surface to be measured.

The sensitivity  $E$  of the spirit level is the movement of the bubble in millimetres or inches which corresponds to a change in slope of 1 millimetre per 1,000 millimetres (0.0125 inch per foot).

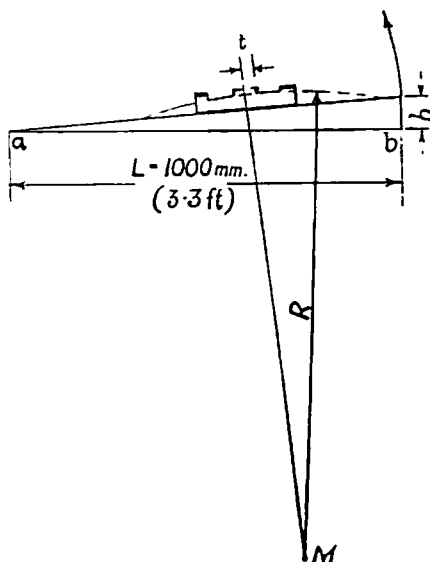

Fig. 5A. Sensitivity of Spirit Level

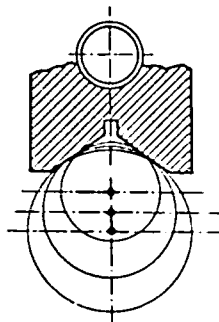

Fig. 5B. Spirit Level and Checking Cylinders

$$E = \frac{\text{Movement of bubble in millimetres (inches)}}{1 \text{ millimetre per metre (0.0125 inch per foot)}}$$

The scale value  $S$  indicates the change in slope (millimetre per metre or inch per foot) necessary for producing a bubble movement of one division. If the distance between two divisions is called  $t$  then  $S = t/E$ . If, for instance, the distance between two divisions is  $t = 2.5$  millimetres (0.1 inch), and a bubble movement of one division corresponds to a change of slope of 0.04 millimetre per 1,000 millimetres (0.0005 inch per foot), then the sensitivity is equal to

$$E = \frac{2.5 \text{ millimetre}}{0.04 \text{ millimetre per metre}} = \frac{0.1 \text{ inch}}{0.0005 \text{ inch per foot}}$$

$$E = \frac{62.5 \text{ millimetre}}{\text{millimetre per metre}} = \frac{200 \text{ inches}}{\text{inch per foot}}$$

and the scale value is

$$S = \frac{2.5}{62.5} = 0.04 \text{ millimetre per 1,000 mm.};$$

$$\text{or } S = \frac{0.1}{200} = 0.0005 \text{ inch per foot.}$$

If for the same change of slope (0.04 millimetre per 1,000 mm., or 0.0005 inch per foot), the space between divisions was 5 instead of 2.5 millimetres, the sensitivity would be increased to  $\frac{125 \text{ millimetres}}{\text{millimetre per metre}}$  and the scale value would be 0.02 millimetre per 1,000 mm.

The inside of the glass tube of a spirit level has a shape of a circular arc of radius  $R$  which moves during a change of slope around the centre  $M$  of its curvature (Fig. 5A). If the slope is measured as a ratio of  $h/L$ , and the movement of the bubble is  $t$ , then  $t/R = h/L$  and  $R = t/(h/L)$ . As  $t/(h/L)$  is equal to  $E$  it follows that  $R = E$ ; in other words, the sensitivity of the spirit level is equal to the radius of curvature of the barrel-shaped bubble tube. The sensitivity of the level depends, therefore, only on the radius of curvature of the bubble tube, and not on the length of its bearing surface. A short accurate level may be more sensitive than a long coarse one (for instance, a mason's level). It is, however, advisable not to use spirit levels which are so short that small deviations are obtained rather than mean values.

If the divisions of a spirit level are spaced 2.5 millimetres (0.1 inch) apart, and if each division represents a change in slope of 0.04 millimetre per 1,000 millimetres (0.0005 inch per foot), then the radius of the inner surface of the bubble tube must be

$$R = \frac{2.5}{0.04} = 62.5 \text{ metres.}$$

$$= \frac{0.1}{0.0005} = 200 \text{ feet.}$$

If double this sensitivity is required then the radius must be increased to 125 metres (400 feet). Spirit levels with radii greater than about 70 metres (220 feet) are difficult to use in the average workshop, as they will not come to rest when machines are running in their neighbourhood.

Errors of spirit levels are caused by:—

- (a) Wrong position of the bubble tube in its housing;
- (b) Faulty graduation.

Scatter of readings depends on:—

- (c) The quality and length of the bearing surface. This should not be shorter than 200 millimetres (8 inches), and if possible 250 millimetres (10 inches) to 300 millimetres (12 inches).
- (d) Dimensional stability of the cast-iron housing;
- (e) Accuracy of the inside of the bubble tube which must have uniform curvature.

Errors and scatter can be ignored in practice if they are less than a quarter of a division; but they sometimes reach half a division in the case of workshop levels (see above). In addition, errors may arise through:—

- (f) The condition of the piece to be tested;
- (g) The influence of temperature;
- (h) Personal errors of the inspector.

(a) The bubble indicates the slope of the spirit-level base in its longitudinal direction. If the surface to be tested is geometrically inaccurate, the base of the level may not lie parallel to it. The position of the level base is thus not accurately determined and the indication of the bubble may be misleading as it refers only to a straight line in the measured direction. If planes are to be checked, therefore, the level must be set down in a number of different directions. An accurate picture of the character of a surface can only be obtained by using additional equipment such as straight-edges, surface plates, auto-collimators, slip-gauges, wires, etc.

(b) Calibration tests should be carried out at a temperature of 20° C. (68° F.). Indication errors are caused by the level being exposed to the sun or to draughts, by being breathed upon, or by being touched with warm hands. The inspector should, therefore, carefully avoid breathing on the bubble tube or touching it. A transparent protecting cover for the bubble tube is often advisable.

(c) It is best to take readings with both eyes open, and looking in a direction perpendicular to the bubble tube. If the inspector is, however, used to closing one eye, this is permissible as long as he does not vary his method of observation. The level must not be used on its edge, but should always be properly pressed to the surface under inspection. Correct measurements are made easier by the use of a cross or circular level, especially when inclined surfaces have to be adjusted. If such an additional level is not available the correct direction of measurement must be found by trial and error, the correct direction being that which gives maximum movement of the bubble.

It is recommended that spirit levels be tested once a month, and, if necessary, adjusted. As the bearing surfaces are often not treated with the necessary care, check tests include those for the following items:

1. Flatness of the bearing surface;
2. Relative position between bubble tube and bearing surface;
3. Scale value.

1. Flatness of the bearing surface is tested and corrected with the aid of a surface plate.

2. The test for relative position between bubble tube and bearing surface is carried out in a temperature-controlled room at 20° C. (68° F.), and, if possible, after the level has been left in the test room for about eight hours (e.g. overnight). The correct testing method is influenced by the shape of the bearing surface. A level with a plane surface can be tested by turning the level through 180°. If the surface is horizontal then the bubble must give the same reading in two positions within not more than  $\pm 0.25$  of a division. For checking a Vee-shaped base, very accurate hardened steel cylinders of different diameters

are required (Fig. 5B). The spirit level is checked and touched up until the two sides of the Vee are parallel with the bubble tube. Care must be taken that a cross level reads zero during each observation. Square frame spirit levels are basically tested by the same methods; in addition, care must be taken to ensure that all bearing surfaces of the level are perpendicular or parallel respectively. This can be done by checking them against accurate master squares (see page 10).

3. To check the scale value, the ratio  $h/L$  per division has to be determined. For this purpose an accurate straight-edge is set up level (checked with a special master spirit level) on equal slip gauges  $a$  and  $b$  (see Fig. 5A), and knife-edges which are 1,000 millimetres (3 feet) apart. The spirit level which is to be checked is then put on the straight-edge. The straight-edge is then inclined by an amount of  $h/1,000$  mm. and, for this purpose, one of the slip gauges is replaced by another one, the difference being equal to the amount  $h$ . If this inclination corresponds to the scale value, the bubble must have moved by one division. This procedure can be continued from one division to the next until the full graduation is checked.

### Level Measurement by Means of Water Level Surface and Micrometer

This method (see Test Charts 41 and 42, Figs. 2 and 3), serves for measuring misalignments or inclinations of long beds and work tables. The micrometer holder is placed at various positions on the bed or table, and the micrometer spindle is screwed down until its tip just touches the surface of the water.

To secure uniform measurements, the measuring tip of the micrometer must be very accurately ground, tinned or, preferably, nickel- or chromium-plated.

In order to obtain a truly level water surface, any throttling effects must be avoided; if tubes are used they must be of large diameter.

When a planing-machine bed is tested during erection of the machine, or in any case, when the table is removed,

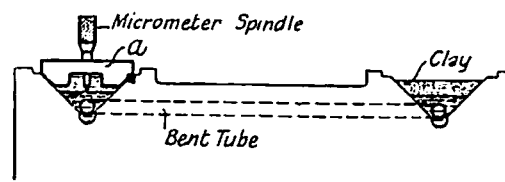

Fig. 6A. Using Vees of Bed as Water Channels when erecting Planing Machine

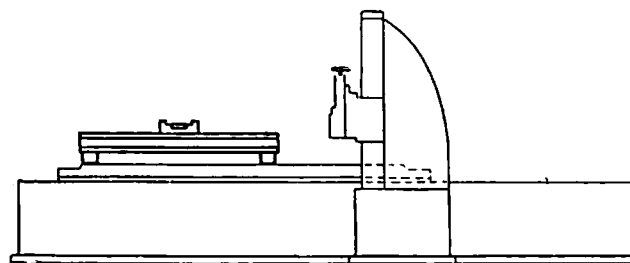
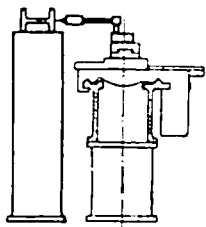
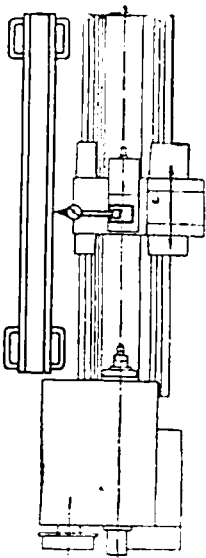

Fig. 6B. Testing Inclination of Bed with Parallels, Straight-edge and Spirit-level



the Vee slideways of the bed can be used as water channels (Fig. 6A). For this purpose they are best sealed at the ends by means of clay or cement and connected by tubes.

The micrometer spindle is then held in an adaptor *a*, the bearing surfaces of which should be exactly perpendicular to each other, and inclined at 45° to the axis of the micrometer screw.



A method which can be considered equivalent to the above employs a long straight-edge placed on parallels, the level of which is checked by a spirit level (Fig. 6B). However, long beds or tables cannot be tested in this manner without repeatedly displacing the straight-edge longitudinally.

#### Testing by Means of Wire and Measuring Microscope

The wire method, Fig. 8, serves for measuring the straightness of movements of tables and carriages over greater lengths (see, for instance, Chart No. 11, Fig. 2). The two ends of the wire are lined-up by means of the cross-wires (Fig. 9) of the measuring microscope.

Observations are taken in the vertical plane as the table is traversed. By means of a special system of prisms, however, the wire can be observed both vertically and horizontally. Each vertical and lateral deviation may be measured by the displacement of the microscope tube. The amount of sag of the wire can be accurately calculated, and the measurements corrected accordingly.

In the case of a lathe or grinding machine, the wire should be arranged to be exactly co-axial with the centres.

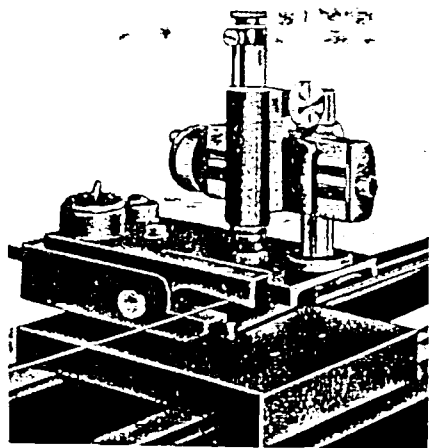
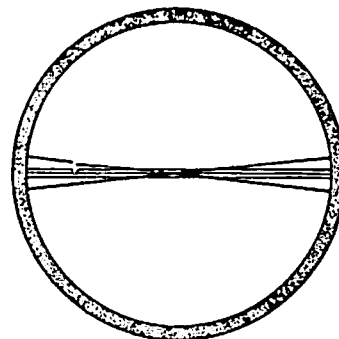

Fig. 8. Method of Testing by means of a Taut Wire and Measuring Microscope

Fig. 9. Diagram showing how the Microscope Cross-wire is centred on the Taut Wire



Care must be taken, however, that the wire is free from kinks. The wire diameter should be as small as possible, in any case not more than 0.1 millimetre (0.004 inch). Long beds up to 20 metres (65 feet) and more can be tested without the need for special precautions. For greater lengths it may be necessary to damp the vibrations of the wire by suitable means, for example, by attaching small paper tags which are suspended in oil.

An equivalent method of checking a movement for straightness employs a long horizontally-located straight-edge which is aligned in such a manner that the dial gauge shows the same reading at both ends of the edge (Fig. 7) (see Chart 15, Fig. 5). While the table is traversed, the deviation of its movement from a straight line can then be read directly from the indication of the dial gauge.

#### Alignment Test by Telescope and Target

The weaknesses of methods which employ the taut wire are avoided if the optical axis of a telescope is used as the rectilinear reference, a suitable target which slides on a carriage on the bed being observed through the eye-piece of the telescope. When the telescope and collimator are used (Fig. 10), the sight mark of the telescope is observed simultaneously with the image of the target formed by the collimator (apparently at infinity). In this manner variations in the angle between the axes of the collimator and the telescope are determined. The method is similar to that using a spirit level.

With the telescope-and-target method, however, the vertical or lateral deviations are measured directly in millimetres (or inches) as the target is moved between its extreme positions *E* and *F* (Fig. 11). The telescope forms a real image by convergent rays. It is necessary, therefore, to focus it always very accurately according to the distance of the target. This is done with the aid of a movable lens within the telescope which is actuated by the knob *K*. In order to avoid errors, the lens must be displaced exactly

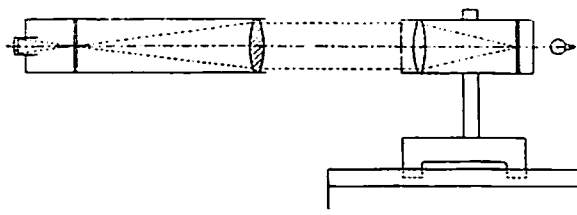

Fig. 10. Diagram illustrating the Principle of Testing by means of Target and Telescope

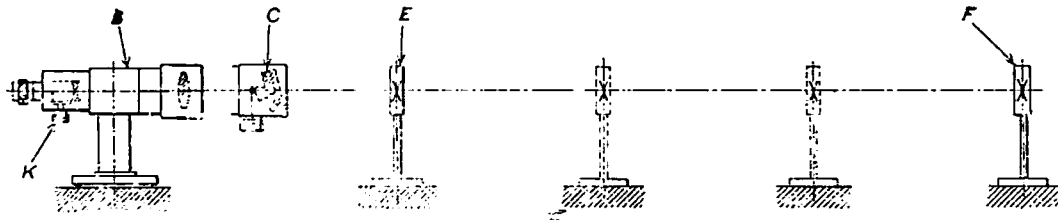

Fig. 11. General Arrangement of Optical Alignment Testing Telescope

along a straight line parallel to the optical axis. The results of the test indicate, at the same time, errors of alignment in both the vertical and horizontal planes of the optical axis. The plane-parallel plate *C* serves for adjusting the optical axis of the telescope relative to the target during the test. The accuracy of the readings depends on the magnifications

of the telescope, the graduation and the distance between the telescope and the target. The measuring accuracy also depends on the precision of the movement of the focusing lens and of the plane-parallel plate. The minimum distance between the target and the telescope is about 1.1 metres (42 inches).

## MAGNITUDE AND DIRECTION OF TOLERANCES

In the test charts, the tolerances are given in three different ways, *viz.*:

1. As plus or minus tolerances (example:  $\pm 0.03$  millimetre per 1,000 millimetres =  $\pm 0.001$  inch per 3 feet);
2. As tolerances without signs (example: 0.03 millimetres per 1,000 millimetres);
3. As unilateral tolerances (example: 0 to 0.03 millimetre per 1,000 millimetres).

1. With plus or minus tolerances, the permissible error is allowed to occur in either direction within the specified reference length. The total range of error is therefore double the specified tolerance (see Fig. 12).

*Example:* A tolerance of  $\pm 0.02$  millimetre per 1,000 millimetres means that, on a reference length of 1,000 millimetres, a deviation of 0.02 millimetre will be permissible in both directions. The total range of error is double the amount of deviation, *i.e.* 0.04 millimetre per 1,000 millimetres (0.0014 inch per 3 feet).

2. Tolerances without signs include the total range of error measured on the reference length, no matter in which direction the error appears (see Fig. 16*b*).

3. With unilateral tolerances, the specified limits cover the total range of error across the total reference length, the direction of error being of great importance and always

stated in the text of the respective test chart (see Fig. 17).

In detail, the tolerances are specified in the test charts and cover the following:

### 1. Straightness of Slideways and Flatness of Tables

These are tested by means of the spirit level.

The tolerances are specified either:

1. As plus or minus tolerances, or
2. As unilateral tolerances.

*Example 1:* Planer bed straight or level longitudinally.

The specified tolerance is  $\pm 0.02$  millimetre per 1,000 millimetres (0.00072 inch per 3 feet).

The spirit level is permitted to deflect from its zero position by 0.02 millimetre per 1,000 millimetres either towards the right or to the left side (Fig. 12).

The measurement may be started at any point of the bed, the spirit level being moved along in definite steps of, say, 300 millimetres (about 12 inches).

The maximum plus and the maximum minus deviation are added together and divided by 2. The resulting error should be within the specified tolerance; in the above

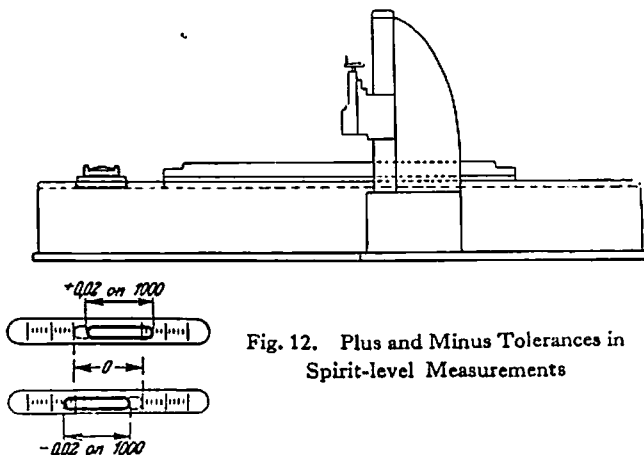

Fig. 12. Plus and Minus Tolerances in Spirit-level Measurements

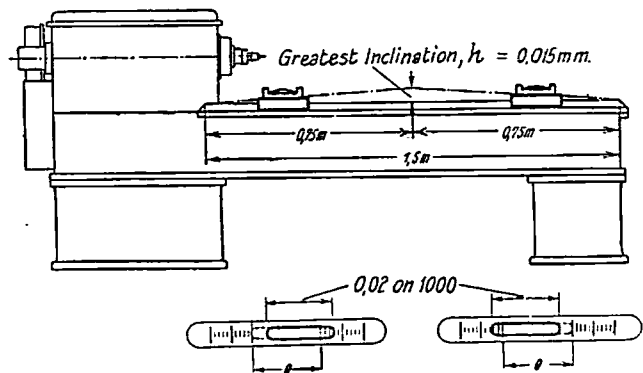

Fig. 13. Unilateral Tolerances in Spirit-level Measurements



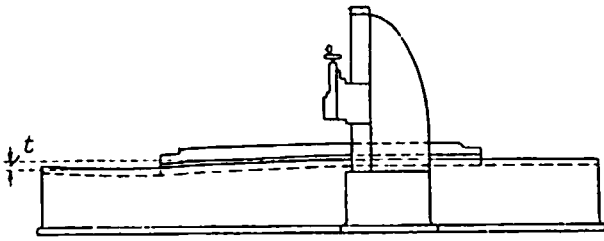

Fig. 14. Tolerances in Measuring the Difference of Height or Sag of a Planer Bed

example within 0.02 millimetre per 1,000 millimetres.

**Example 2:** Lathe bed straight or flat in the longitudinal direction (convex only).

The specified tolerance is 0 to 0.02 millimetre per 1,000 millimetres (0.00072 inch per 3 feet).

The spirit level is allowed to deflect in one direction only, *i.e.* rising towards the centre (Fig. 13) and within the limits of 0 and 0.02 as measured on a reference length of 1,000 millimetres, with the result that the bed will be only convex.

The measurement is started at the centre of the bed, *i.e.* at its peak or hump, where the spirit level should read zero as accurately as possible. From this point the spirit level is moved to the right and to the left, *i.e.* towards each end. The level should be used on a bridge (see Fig. 6b) the feet of which are spaced about 12 inches apart.

The slope has its largest permissible value if the spirit level indicates the maximum reading 0.02 per 1,000 millimetres (convex) along the left, and the opposite reading along the right half of the bed. In this case the bed ways would rise in a straight line from the left and right ends towards the centre with an incline of 0.02 millimetre per 1,000 millimetres. The largest permissible rise of a bed having a length of 1.5 metres (5 feet), would be  $h = 0.75 \times 0.02 = 0.015$  millimetre (about 0.0006 inch).

#### FLATNESS OF TABLES AND BEDS OF LONG PLANING MACHINES

The flatness is measured separately in the case of long planing machines only.

The specified tolerance represents directly the permissible difference in height between the highest and lowest point of the bed or table being tested.

**Example:** Bed of a long planing machine straight in the longitudinal direction; largest difference in height, 0.05 millimetre (0.002).

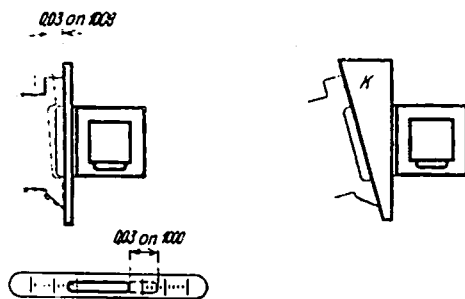

Fig. 15A. Tolerances in Testing a Surface for Flatness

Fig. 15B. Use of an Intermediate Piece for Inclined Surfaces

In Fig. 14 the deviation of a planer bed from its theoretical straightness is shown. The measured amount *t* must be within the tolerance of 0.05 millimetre (0.002 inch).

#### 2. Flatness of Slideways (Twist of Cross Rails and Arms)

These are tested by means of the spirit level.

The tolerances are specified without signs.

**Example:** Front slideway of the planer rail flat within 0.03 millimetre per 1,000 millimetres.

The spirit level is moved along the surface to be tested. The range of the largest readings taken in both directions indicates the error which must be within the specified tolerance of 0.03 millimetre per 1,000 millimetres (Fig. 15). It is not necessary for the measured surface to be vertical or horizontal, *i.e.* for the spirit level to be in its zero position. The surface being tested may lie at any angle, and a wedge-shaped piece *K* (Fig. 15b) may be interposed so that the air bubble lies near zero.

#### 3. Alignment of Slideways and Axes, or Centre Lines Parallel or Perpendicular to each other

These are tested by means of the dial gauge or the spirit level.

The tolerances are specified in the form of either: (1) tolerances without signs, or (2) unilateral tolerances. In each case the specified tolerance represents the total range within which the dial pointer is allowed to deflect.

**Example 1:** Milling spindle parallel with bed.

The specified tolerance is 0.02 millimetre per 300 millimetres (0.0008 inch per foot) (Fig. 16a).

The dial gauge is applied at the initial point of the measuring distance of 300 millimetres (12 inches) and traversed along the latter. During this traverse the total movement of the pointer must not exceed 0.02 millimetre (0.0008 inch) no matter in which direction the movement takes place.

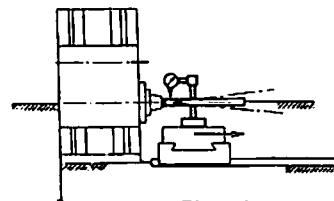

Fig. 16A

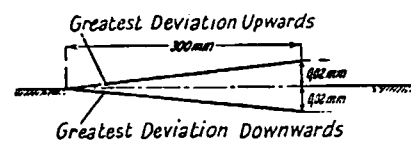

Fig. 16B

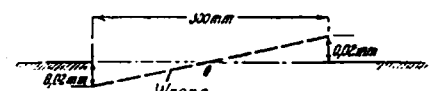

Fig. 16C

Fig. 16A, 16B and 16C. Double-sided Tolerances for Directional Measurements

It is by no means correct to set the dial gauge to zero at any point in the centre of the measuring distance, so that it shows a deviation of 0.02 millimetre in one direction when moved to the left, and of 0.02 millimetre in the opposite direction, when moved to the right; such a procedure would be wrong because the total error would be doubled ( $2 \times 0.02 = 0.04$  millimetre = 0.0016 inch, Fig. 16c, dotted line).

When a spirit level is used for this test, the total movement of the air bubble must not exceed a value corresponding to a change of inclination of 0.02 millimetre per 300 millimetres.

**Example 2:** Lathe spindle parallel with bed in the vertical plane (spindle rising towards the free end of test mandrel only).

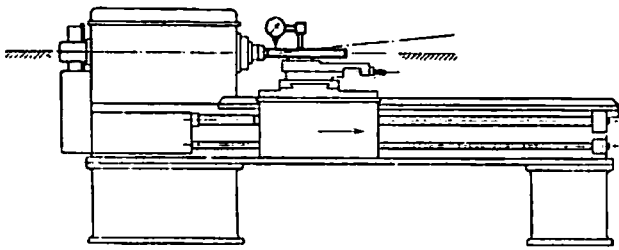

Fig. 17A

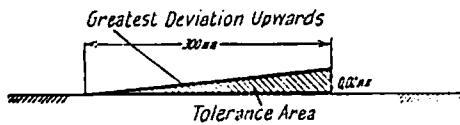

Fig. 17B

Fig. 17A and 17B. Unilateral Tolerances for Directional Measurements

The specified tolerance is 0 to 0.02 millimetre per 300 millimetres (Fig. 17A).

When the dial gauge is being moved along the test mandrel, the pointer is allowed to deviate in the stated direction only (Fig. 17B).

The same applies to the testing for perpendicularity of surfaces relative to axes and vice versa.

The perpendicularity of an axis relative to a slideway is usually measured by means of the turn round (trammel) method. The dial gauge is set to zero when it touches the surface to be tested at the left side; it is then turned round and the deviation of the pointer should not exceed the permitted tolerance when the dial gauge touches the surface to be tested at the right side. The direction of deviation is of no importance.

**Example:** T-ee-slots in the table of a surface milling machine square with cutter spindle. The tolerance specified is 0.02 millimetre per 300 millimetres (Fig. 18A).

The dial gauge touching the centre T-slot in the left-hand position is set to zero. In turning it round—the total distance between the two measuring positions is 300 millimetres (12 inches), i.e. the length of the lever arm is 150 millimetres (6 inches)—the deviation of the dial pointer must not exceed 0.02 millimetre (0.0008 inch) towards the left or right (Fig. 18B). With lever arms of

different lengths the tolerances must be converted accordingly.

It is not permissible for the dial pointer to deviate by 0.02 millimetre in one direction when touching the left side, and by the same amount in the opposite direction when touching the right side of the T-slot (Fig. 18c), because these deviations would correspond to an inadmissible squareness error amounting to 0.04 millimetre per 300 millimetres (0.0016 inch per foot).

#### 4. Alignment and True Running of Shafts

The tolerances for the true running of a shaft have to be taken as the admissible total deviation (range of deviation) of the dial-gauge pointer.

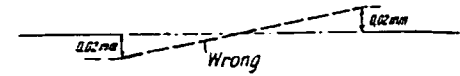

Fig. 18c

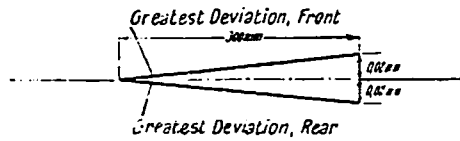

Fig. 18B

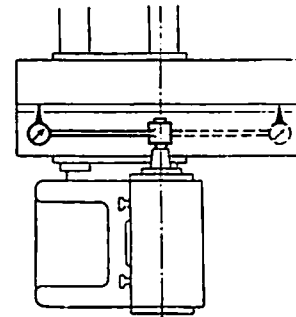

Fig. 18A

Figs. 18A, 18B and 18C. Tolerances in Measuring by the Turn-round Method

**Example:** Testing lathe spindle for true running. The specified tolerance is 0.01 millimetre (0.0004 inch). During one revolution of the spindle, the dial pointer is allowed to deviate over a range of 0.01 millimetre.

Similarly, the tolerances specified for the axial sliding movement (slip) of spindle indicate the total permissible deviation of the dial-gauge pointer.

The tolerance specified for the alignment of two shafts indicates the permissible deviation of their axes from the theoretical centre line (the amount of off-centre). If this is measured by means of a dial gauge, using the swing-over method, the deviation of the dial-gauge pointer would be twice the amount of off-centre, as shown in Fig. 19. The dial gauge pointer is thus allowed to deviate by twice the permissible error in this case.

**Example:** Testing the alignment between the bore of the outer arbor support and the cutter spindle of a surface milling machine. The tolerance specified is 0.02 millimetre (0.0008 inch).

When the swing-over method is used, the dial gauge pointer may deviate by 0.04 millimetre (0.0016 inch).

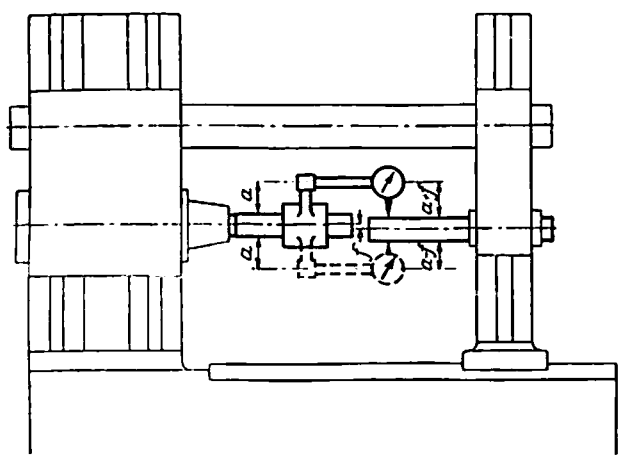

Fig. 19. (See page 31 and Fig. 1A-C). Tolerances in Testing the alignment of Two Axes by the Swing-over Method

### 5. Lead or Pitch Error of Lead-screws

The lead or pitch error is generally based on a reference length of 300 millimetres (12 inches). Beginning from any given initial position, the test nut is moved over a number of threads corresponding to an accurate travel of 300 millimetres for metric or 12 inches for Whitworth thread screws. The actual travel of the nut may be either larger or smaller than 300 millimetres and 12 inches, respectively, by not more than the specified permissible lead error.

*Example:* The accuracy of the lead-screw of a lathe is usually assured by the manufacturer. The tolerance specification is 0.03 millimetre per 300 millimetres (0.0012 inch per foot). Let the lead-screw have a pitch of  $\frac{1}{8}$  inch. The nut is moved by exactly 48 threads corresponding to a basic length of travel of 12 inches. The actual length of travel is allowed to vary by not more than 0.0012 inch from the nominal length of 12 inches.

The problem of accurate screw-cutting on a lathe cannot be solved merely by using an accurate lead-screw which meets the test specifications. It is necessary for the lathe itself to be of rigid design and for the lead-screw to be carefully mounted, otherwise an accurate lead-screw may give inaccurate results. Moreover, the accuracy of the driving gear, the rake angles of the tool, the smoothness of its cutting edges, the coolant supply, etc., have considerable influence on the accuracy of the thread to be cut.

#### TESTING METHODS

Fig. 20 shows a very simple method for testing a lead-screw over a measuring length of 300 millimetres (12 inches). This has been employed in practice for more than 50 years, and can be carried out with equipment usually available in the machine shop. The method involves taking two measurements over a given distance (say 300 millimetres or 12 inches) the carriage being traversed along the bed by means of the lead-screw.

1. The first measurement is taken with a dial gauge *M* touching a precision length gauge *a*.
2. For the second measurement, the position of the carriage is determined by means of the dial gauge *M* after the length gauge *a* has been removed.

The distance to be measured is referred to the adjustable

stop *A*, which is rigidly clamped to the lathe bed. The position of the face plate is determined by the adjustable ring *R*, which is held firmly against a stop block *b*\* by a constant weight on a lever. In testing the finished lathe, the accuracy of all the co-operating transmitting members is tested by comparing two measurements as follows:

In the starting position shown at the top (Fig. 20A) the ring *R* firmly touches the block *b*. The slide carrying the dial gauge *M* is so adjusted that the length gauge *a* just touches the stop *A* at its left and the plunger of the dial gauge at its right end. A pressure of about 50 grammes on the dial gauge plunger is sufficient to ensure the necessary contact. After the reading of the dial pointer has been taken in this position, the length gauge *a* and the block *b* are removed. The lathe spindle with the face plate is then turned until the calculated distance through which the slide has been traversed by the lead-screw corresponds to the length of the precision length gauge *a* (300 millimetres or 12 inches).

If the ring *R* is again brought into contact with the stop block *b*, the dial-gauge plunger should just touch the face of the stop *A*, provided that the lead-screw is free from errors. Any deviation of the dial pointer indicates the magnitude of the error. In other words, it corresponds to the plus or minus variation between the movement of the carriage and the length of the gauge *a*. In this way, either cumulative pitch errors of the lead-screw over its full length or individual errors of each thread can be determined. Fig. 22 shows a test chart of a lead-screw of 6 millimetres ( $\frac{1}{4}$  inch) pitch and 3,360 millimetres (11 feet) length.

Cutting tests can be carried out by cutting a right and a left hand thread on a cylindrical test piece having a length of at least 10 times the pitch, the pitch errors being determined by a suitable indicator. The maximum permissible error is  $\pm 0.003$  millimetre (0.00012 inch) for each pitch, and the cumulative error should not exceed that of the lead-screw. For a medium quality screw, 0.02 per 50 millimetres (0.0008 inch per 2 inches) is

\* Block *b* could be replaced by a dial gauge.

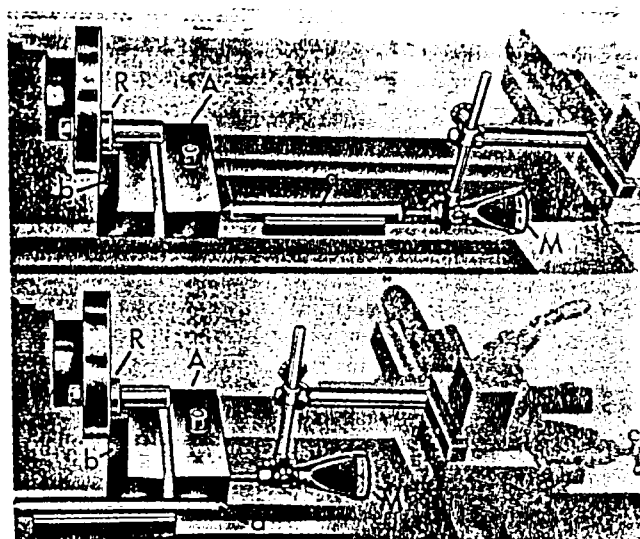

Fig. 20A (Top); Fig. 20B (Bottom). Method of Measuring Lead-screw Errors by Comparison with an End Gauge.

allowed. Fig. 22 shows the test chart of a good lead-screw, Fig. 23 a test chart of a corresponding right-and left-hand screwed test piece, 6 millimetres pitch and 22 threads, cut with the lead-screw.

### Principle of the "Cazeneuve" Test

Another simple and practical method of testing has been proposed by Cazeneuve (France).

As in the former test, the accuracy of the lead-screw is checked by determining the movement of the saddle produced by the rotation of the lead-screw. The distance travelled by the saddle is measured by means of a microscope and a graduated scale, the dividing errors of which are known.

### Description of the Measuring Device (Fig. 21)

The graduated scale *a* is positioned in the centre of the lathe bed where it is located and held by means of the clamps *b* which are similar to those used for clamping the tailstock. The saddle carries a microscope *c*, the eye-piece of which is fitted with a micrometer cross-hair.

### The Method of Measuring

If only those traversing errors which result from the lead-screw are to be determined, the lead-screw is driven from the tailstock end. If the measurements must include the errors of the train of gears in addition to those of the screw, the lead-screw is driven from the headstock end via the usual gear drive.

In the first instance, a lever is mounted on the lead-screw at the tailstock end. This lever must be sufficiently long to reduce errors in the angular readings to a minimum.

In practice, a lever of 500 millimetres (about 20 inches) radius is used, giving a total circumferential movement of  $2 \times 500 \times \pi$ , i.e. approximately 3,000 millimetres for one full revolution. This corresponds then to a saddle displacement equivalent to one pitch of the lead-screw. If the pitch is assumed to be 12 millimetres (approximately  $\frac{1}{2}$  inch), and if the angular positioning of the lever is determined by reference to a precision block gauge the errors are reduced in the ratio of 12 : 3,000 and their effect is thus negligible.

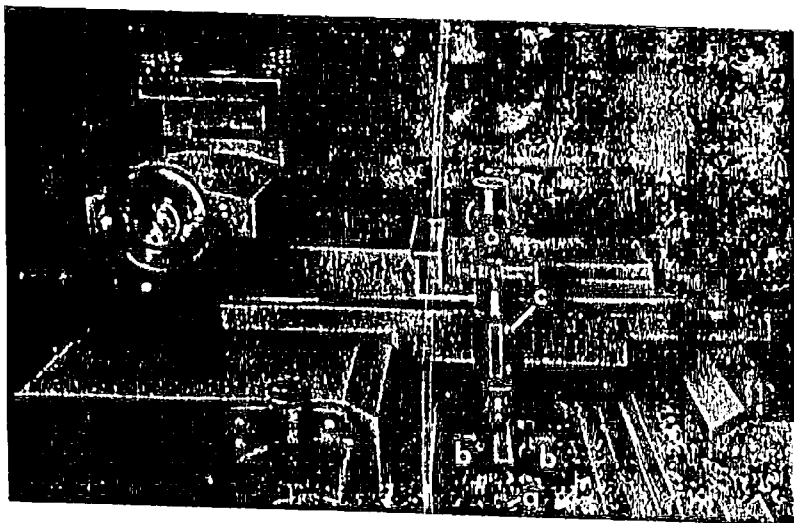

Fig. 21. View showing the Microscope and Scale used in the Cazeneuve Lead-screw Test

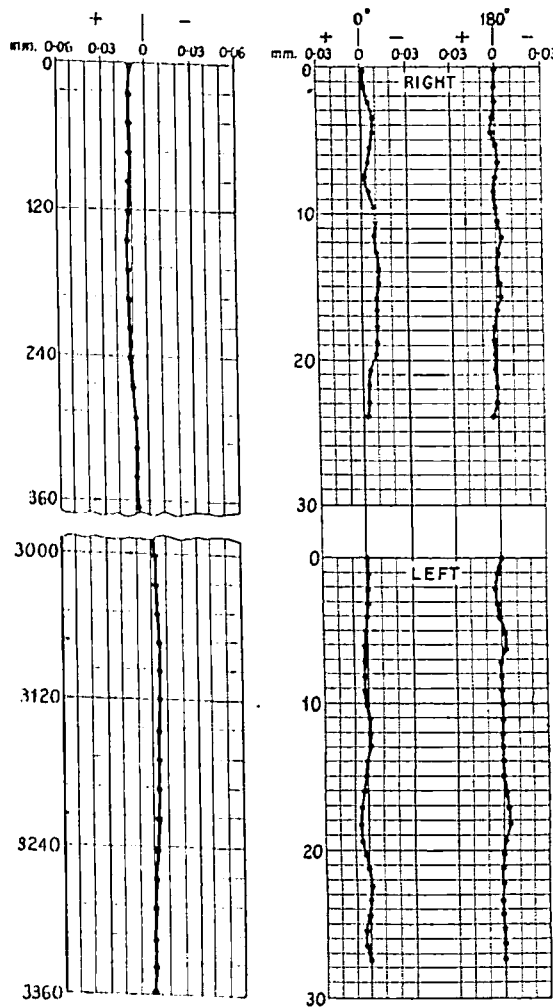

Fig. 22 (Left). Test Chart for an Accurate Lead-screw

Fig. 23 (Right). Test Charts for Screwed Test-pieces with Right- and Left-handed Threads

If the drive is taken from the main spindle, a face-plate of the largest permissible diameter is mounted on the spindle and its rotation checked accurately by means of a stop, a dial gauge or other means. Errors are again small and of the order 1 : 200 or 1 : 300.

Irrespective of which of the two alternative methods is employed, testing can be carried out pitch by pitch and, if necessary, even by fractions of a pitch. By comparing the results obtained with the two different methods of moving the saddle (either by the lead-screw alone or from the main spindle), the errors due to the train of gears can be determined.

It is also possible to check pitch errors produced on all kinds of threads, including metric, Whitworth and

module pitches, whether these errors are due to the lead-screw itself or to other causes, such as for instance, the Norton-type gear box. The accuracy of the testing device depends only on the quality of the steel or glass scale, the errors of which are known from a calibration curve.

British makers of repute distinguish between "Standard Guarantee" and "Special Accuracy". An example is shown in the following specification\*:

1. *Standard Guarantee* with any lathe:

$\left\{ \begin{array}{l} +0.002 \text{ inch } (+0.05 \text{ millimetre}) \\ -0.003 \text{ inch } (-0.075 \text{ millimetre}) \end{array} \right\}$  in any 6 foot (1,800 millimetres) length.  
 $\pm 0.001 \text{ inch } (\pm 0.025 \text{ millimetre})$  in any foot (300 millimetres).

2. *Special Accuracy*, which can be provided at increased cost:

6½ inch (165 millimetres) centre lathe on 6 foot (1,800 millimetres) length of bed.

8½ inch (215 millimetres) centre lathe on 8 foot (2,400 millimetres) length of bed.

Error not to exceed  $\left\{ \begin{array}{l} +0.0006 \text{ inch } (+0.015 \text{ millimetre}) \\ -0.001 \text{ inch } (-0.025 \text{ millimetre}) \end{array} \right\}$  in any foot (300 millimetres), or  $\left\{ \begin{array}{l} +0.001 \text{ inch } (+0.025 \text{ millimetre}) \\ -0.002 \text{ inch } (-0.050 \text{ millimetre}) \end{array} \right\}$  in the length capacity of the lathe.

6½ inch (165 millimetres) centre lathe on 8 foot (2,400 millimetre) length of bed.

8½ inch (215 millimetres) centre lathe on 10 foot (3,000 millimetres) length of bed.

\* Dean, Smith & Grace Limited (Keighley), 1949.

10½ inch (275 millimetres) centre lathe on 10 foot (3,000 millimetres) length of bed.

Error not to exceed  $\left\{ \begin{array}{l} +0.0006 \text{ inch } (+0.015 \text{ millimetre}) \\ -0.001 \text{ inch } (-0.025 \text{ millimetre}) \end{array} \right\}$  in any foot (300 millimetres), or  $\left\{ \begin{array}{l} +0.001 \text{ inch } (+0.025 \text{ millimetre}) \\ -0.0025 \text{ inch } (-0.064 \text{ millimetre}) \end{array} \right\}$  in length capacity of the lathe.

Length of bed more than above: Error not to exceed—

$\left\{ \begin{array}{l} +0.0006 \text{ inch} \\ -0.001 \text{ inch} \end{array} \right\}$  in any foot ;  $\left\{ \begin{array}{l} +0.001 \text{ inch} \\ -0.0025 \text{ inch} \end{array} \right\}$  in any 6ft. length at any part of screw.

6. *Pitch Errors of Gears and Dividing Errors of Dividing Heads*

The term "permissible single error" indicates the tolerance by which the actual pitch is allowed to be larger or smaller than its prescribed basic size.

The cumulative pitch error is the amplitude of the tooth error curve plotted against the number of teeth (see Fig. 25). It is taken from the record produced by the gear-testing device or computed from measured single errors as follows:

*Example:* To determine the total pitch error of the dividing wheel for a gear-cutting machine from its single-pitch errors.

Data of the selected dividing wheel: Pitch diameter, 600 millimetres (about 24 inches); number of teeth, 60; module, 10 millimetres (D.P.=2.54).

In the Table (Fig. 24) the measured single-pitch errors

Tooth No.	Single Error		Total Error		Tooth No.	Single Error		Total Error	
	mm.	Inch	mm.	Inch		mm.	Inch	mm.	Inch
1	+0.01*	+0.0004	±0	±0	31	+0.005	+0.0002	+0.065	+0.0026
2	+0.01	+0.0004	+0.01	+0.0004	32	-0.015	-0.0006	+0.05	+0.0020
3	-0.005	-0.0002	+0.005	+0.0002	33	-0.01	-0.0004	+0.04	+0.0016
4	-0.01	-0.0004	-0.005	-0.0002	34	+0.005	+0.0002	+0.045	+0.0018
5	+0.015	+0.0006	+0.01	+0.0004	35	-0.01	-0.0004	+0.035	+0.0014
6	+0.015	+0.0006	+0.025	+0.0010	36	-0.015	-0.0006	+0.02	+0.0008
7	+0.01	+0.0004	+0.035	+0.0014	37	-0.015	-0.0006	+0.005	+0.0002
8	-0.005	-0.0002	+0.03	+0.0012	38	-0.01	-0.0004	-0.005	-0.0002
9	+0.01	+0.0004	+0.04	+0.0016	39	+0.005	+0.0002	±0	±0
10	±0	±0	+0.04	+0.0016	40	-0.015	-0.0006	-0.015	-0.0006
11	-0.005	-0.0002	+0.035	+0.0014	41	-0.01	-0.0004	-0.025	-0.0010
12	-0.01	-0.0004	+0.025	+0.0010	42	-0.015	-0.0006	-0.04	-0.0016
13	±0	±0	+0.025	+0.0010	43	-0.005	-0.0002	-0.045	-0.0018
14	-0.005	-0.0002	+0.02	+0.0008	44	±0	±0	-0.045	-0.0018
15	+0.015	+0.0006	+0.035	+0.0014	45	-0.01	-0.0004	-0.055	-0.0022
16	+0.005	+0.0002	+0.04	+0.0016	46	-0.015	-0.0006	-0.07	-0.0028
17	+0.01	+0.0004	+0.05	+0.0020	47	+0.01	+0.0004	-0.06	-0.0024
18	±0	±0	+0.05	+0.0020	48	-0.015	-0.0006	-0.075	-0.0030
19	+0.005	+0.0002	+0.055	+0.0022	49	±0	±0	-0.075	-0.0030
20	-0.01	-0.0004	+0.045	+0.0018	50	-0.005	-0.0002	-0.08	-0.0032
21	+0.015	+0.0006	+0.06	+0.0024	51	+0.01	+0.0004	-0.07	-0.0028
22	+0.01	+0.0004	+0.07	+0.0028	52	+0.015	+0.0006	-0.055	-0.0022
23	-0.005	-0.0002	+0.065	+0.0026	53	+0.005	+0.0002	-0.05	-0.0020
24	±0	±0	+0.065	+0.0026	54	+0.015	+0.0006	-0.035	-0.0014
25	+0.01	+0.0004	+0.075	+0.0030	55	+0.01	+0.0004	-0.025	-0.0010
26	+0.015	+0.0006	+0.09	+0.0036	56	-0.005	-0.0002	-0.03	-0.0012
27	-0.01	-0.0004	+0.08	+0.0032	57	+0.015	+0.0006	-0.015	-0.0006
28	-0.015	-0.0006	+0.065	+0.0026	58	+0.01	+0.0004	-0.005	-0.0002
29	±0	±0	+0.065	+0.0026	59	+0.01	+0.0004	+0.005	+0.0002
30	-0.005	-0.0002	+0.06	+0.0024	60	-0.015	-0.0006	-0.01	-0.0004

Fig. 24. Single and Total Pitch Errors of an Indexing Wheel

\* Error between tooth No. 60 and tooth No. 1

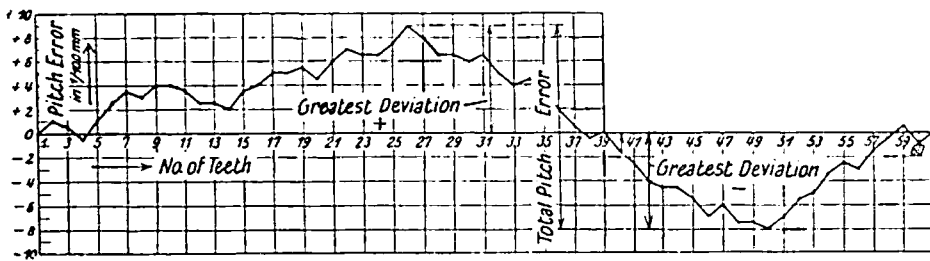

Fig. 25. Diagram of Pitch Errors of a Dividing Gear

(millimetres and inches) are contained in the second and third columns. The fourth and fifth columns contain the cumulative errors, i.e. the algebraic sum of the single errors. In the graph of cumulative errors (Fig. 25) the sum of the single errors is plotted progressively over the numbers of teeth. From the selected example it will be seen that the

largest positive deviation occurs near tooth No. 26 with an amount of +0.09 millimetre (0.0036 inch) and the largest negative deviation near tooth No. 50 with an amount of -0.08 millimetre (0.0032 inch). The total error (amplitude of the curve in Fig. 25) is, therefore, 0.17 millimetre (0.0068 inch).

## DETAILS FOR TESTING VARIOUS MACHINE TOOLS

### Milling and Gear Cutting Machines, Tables 1-7

In establishing the permissible errors of horizontal milling machines, consideration was given to the fact that, in the direction parallel to the cutter spindle, the work table must not droop, but is permitted to rise only towards the front face of the knee. While working, the table tends to droop under the influences of the weight of the work-piece and of the cutting force, while the cutter arbor tends to be deflected upwards. As in other cases, great importance had to be attached therefore to the necessity of the tolerance being in the opposite direction to the expected deformations under load; tolerances and deformations should never be cumulative.

In universal milling machines the off-set of the swivel axis and the centre T-slot with respect to the cutter spindle must also be tested. Both alignments must be within close limits in order to obtain undistorted profiles when helices are milled.

In the case of thread-milling machines, a special test is carried out in order to ensure that the cutter axis is at the same height as the work spindle. Unless this requirement is met, true thread profiles cannot be produced.

The permissible errors of gear-cutting machines are very small, because modern requirements for quick and quiet running conditions and, therefore, accurately-cut gears must be met. It has not been considered possible, however, to specify tolerances below 0.02 millimetre (0.0008 inch), because the drive mechanisms of gear-cutting machines are relatively complicated and the gear trains are rather long. These facts make it difficult to maintain very high degrees of accuracy in the normal manufacturing process.

The most important component of a satisfactory gear-cutting machine is the dividing wheel which primarily controls the accuracy of the gears cut on the machine. Close tolerances have been specified for single-pitch and cumulative error. It is necessary to limit the cumulative pitch error in order to prevent a large number of successive single errors occurring in the same direction (plus or minus). Gears produced with such errors result in non-uniform velocity transmission, and cause noisy running conditions,

periodic shocks or impacts, and perhaps vibration. In printing and similar machines gear-driven rolls have to act upon parts of low strength. Even small cumulative errors of the gears driving the rolls will cause irregularities in the drive and thus damage the parts transported by the rolls.

### Lathes, Capstan and Turret Lathes, Automatic Lathes and Vertical Boring Machines, Tables 11-20

Lathes are grouped in accordance with their uses, their sizes and the degree of accuracy required from them. Experience shows that lathe beds wear more rapidly in the centre than at the ends. Moreover, the overhanging weight of the carriage and the cutting resistance force the front shears (apron side) down and lift the rear shears. Hence, the tolerance must be directed in opposition to this deformation. The front shears of a new lathe are therefore permitted to be arched or humped upwards only, while the rear shears may be less convex or even slightly concave. To avoid the undesirable combination of a maximum convex tolerance for the front shears and a maximum concave tolerance for the rear shears, a spirit level test for twist in the transverse direction is also carried out.

The headstock should be so aligned that an arbor inserted in the spindle nose rises or inclines upwards only at its free end with respect to the bed ways, whilst inclining in the horizontal plane towards the tool post only. This will counteract the deformations resulting from the weight of the workpiece and the cutting force. Similarly, the tailstock spindle when fully advanced is only permitted to deflect in the corresponding directions.

The slideway surfaces of the lathe bed are not only datum faces for levelling the machine but also working surfaces for guiding the carriage and the tailstock. The quality of these sliding surfaces, of whatever design, is of vital importance for the accuracy of workpieces produced on the lathe. These slideways vary in length from 12 inches to 60 feet and more. Whilst the long tables of planing, grinding or milling machines cover a large portion of the slideways, the short carriage of the lathe leaves the slideways wide open. Special care has therefore to be taken in their manufacture. For this reason the tests on

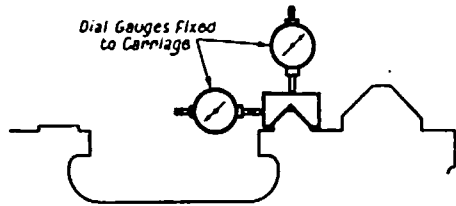

Fig. 26. Checking the Parallelism of Guideways

Charts 11, 12, 13, Fig. 3 were specified. These serve for making certain that the locating elements of the three main parts (headstock, tailstock and stay) are accurately aligned both vertically and horizontally with the carriage slideways over their full length. Moreover, the tailstock guides must be carefully scraped or ground. The tests of the slideways are carried out by putting the plunger of the dial gauge directly on their scraped or ground surfaces. If the surfaces are tested in this manner along three lines (see Chart 11, Fig. 3), this can be done in a few minutes and the alignment and the quality of these important sliding surfaces can be judged. There is no objection in principle to inserting a block (Fig. 26) between the slideway and the dial-gauge plunger, but by doing so the surface quality cannot be determined. Instead of the intermediate block (Fig. 26) the tailstock itself is sometimes used. In this case, however, slight movement between the tailstock proper and its base due to tightening or loosening of the clamping screws may cause errors which can be avoided if a simple measuring block or bridge is used. It is, perhaps, unnecessary to point out that in the case of long and large size lathes the use of the tailstock for such measurements is completely out of the question.

All tailstock-quill measurements must be taken with the quill in the clamped position. Although the test Chart 11, Fig. 9 is the only check on the parallelism between the tool-rest slide and the spindle in the vertical plane, this is important because in this very complex assembly the guides for three rectilinear movements and one rotating movement are superimposed. In the case of a high-quality machine it is, therefore, necessary to ensure that a final test of the cumulative error caused by this super-position be carried out. If the tool-rest slide is used for automatic feed movements (for instance for the turning of spheres) its movement has to be as accurately tested as that of all the other moving parts. In this case, it would even be necessary to test the vertical alignment of the swivelling axis which can be checked by a turn-round method. Firms of repute carry out this test for all their machines. It should be mentioned however that the specification Chart 11, Fig. 9 has been slightly relaxed because of the relatively lesser influence of any error in height upon the cylindrical or tapered shape of the workpiece. As the straightness of the tool-rest movement is important in the case of automatic feed drives, a test in this respect has been added.

The lead-screw is one of the most important parts of the lathe. It is of the same importance as the main spindle. Various errors may affect the accuracy of the screw thread produced on a machine; *viz*:

1. The pitch error of the lead-screw.
2. The axial slip of the lead-screw due to faulty thrust bearings.

3. The alignment of the lead-screw axis in relation to the carriage slideways.

4. The axial slip of the main spindle.

5. Errors in the transmission of the feed drive from the main spindle to the lead-screw through a Norton gear box or other means.

The lead-screw is subjected to quite unusual loads. The end bearings locate it axially and radially. The nut in the apron which transmits the drive from the lead-screw to the carriage is usually split and has to be opened and closed repeatedly. It also supports the lead-screw at any point throughout its full length. The position of the split nut is determined by the slideways of the bed. It is therefore essential to test the alignment of the lead-screw relative to the bed slideways. The permissible errors (0.1 to 0.2 millimetre or 0.004 to 0.008 inch—according to the size of the lathe) has been determined in relation to the influence which the misalignment of the lead-screw exerts upon the pitch accuracy of the thread produced.

It is not permissible to reduce the permissible pitch errors specified for a measuring distance of 300 millimetres (12 inches) *pro rata* of other measuring lengths. If necessary, the following values may be used for the case of a specified tolerance of 0.03 per 300 millimetres (0.0012 inch per foot): error measured over 125 millimetres (5 inches) to be 0.02 millimetre (0.0008 inch); cumulative error over 1,000 millimetres to be 0.08 millimetre (0.0032 inch).

Turret lathes are grouped according to their size. The basic test instructions apply to machines with both hexagon and drum-type turret heads. They do not apply, however, to turret lathes arranged with hollow recessed turret heads, in which centring recesses locate the cylindrical shanks of drills, counterboring tools, reamers, taps, etc., by means of adapter bushings or tool holders. Two supplementary instruction sheets, No. 16A and 17A are provided for this type of turret lathe.

The turret head is also tested for positional rigidity in its bearing and indexing holes. To this end, the inspector tries to turn the turret head about its axis by hand with the aid of a lever having a length of 0.5 or 1 metre (1.7 or 3.4 feet). The actual angular displacement is measured by means of a dial gauge.

#### Grinding Machines, Tables 21-26

The wheel slide of the cylindrical grinder must be so aligned that the spindle of the grinding wheel and the workhead are at the same level. The specified tolerance of 0.1 millimetre (0.004 inch) ensures that the generating lines of a taper ground on the machine are straight and not hyperbolic, deviations being noticeable only when the difference in height is far larger.

The levels of the axes are checked in accordance with Chart No. 21, Figs. 13 and 14 by mounting two cylindrical mandrels of equal diameter on the wheel and work spindles and placing a straight-edge with a spirit level across these two cylinders. The swivel table is then swung several times to and fro into its two end positions. Changes of deflection of the spirit level, if any, are compensated for by placing precision gauge-blocks on to the gauge cylinders until the deflection remains constant while swinging the swivel table. It is not essential in this test for the bubble to be in its zero position. The difference of the two gauge blocks placed on the cylindrical mandrels on the wheel and work spindles indicates directly the difference in height of the spindle axes above the swivel table.

The next measurement concerns the rise and fall of the wheel-head slideway, and therefore of the wheel spindle, while the wheel is fed towards the work table (Chart 21, Fig. 14). The position of the spirit level in the test of Fig. 13 is used as a starting point. After each adjustment of the wheel slide, the precision gauge blocks on the wheel spindle are changed until the indication of the spirit level remains constant.

According to Figs. 13A and 14A (Test Chart 21), similar tests are prescribed for a grinding table with a horizontal surface. In these tests it is assumed that the table surface is parallel to that of its swivel-plate. Variations in this connection, which may occur during manufacture are, however, negligibly small when compared with the specified tolerance for the difference in height of the two spindle axes. The movement of the wheel slide must respond with great sensitivity and consistency to the precision depth setting operation. Moreover, it must return to its set position after the grinding wheel has been withdrawn and fed forward again. When the depth setting for the grinding wheel is tested, other settings of the machine must not be disturbed.

In order to test the direction of the in-feed motion of the wheel slide, a flattened test mandrel is mounted between the centres and a square pressed against its flat surface; the plunger of the dial gauge which is secured to the wheel slide traces the free leg of the square (Chart 21, Fig. 15). A test grinding operation is carried out without the use of steady rests, as these should not influence the test results of the machine itself. A good grinding machine, once set for cylindrical grinding, should grind cylindrically or rather slightly convex, since compensation for concave grinding is very difficult indeed, whereas a slight convexity may be eliminated by corresponding adjustment of the steady rests. Slightly convex grinding may even be desirable so that the steady rests can be correctly set.

Similarly, deviations from the straight line movement of the table are permissible as long as they result in convex grinding.

#### Drilling and Boring Machines, Tables 31-38

Separate test charts have been compiled for heavy upright, light pillar and radial drilling machines. Tolerances for light pillar drills are wider than tolerances for the rigid upright machines, because they are of lighter design.

The basis for the alignment tests is in all cases the position of the upright, pillar, or column relative to the base plate. This is of particular importance in the case of radial drilling machines in which the position of the spindle axis depends to a great extent upon the alignment of the radial arm during its movement on the column. If the axis of the column is not at right angles to the base plate, a compensation of the resulting error would be possible for only one position of the radial arm, whilst in any other position the error would be magnified. For this reason it is essential that the base plate is stiff and accurate. With today's workshop equipment it should not be difficult to align the column vertical to its base. All other conditions, such as rectangular alignment between spindle and base plate, parallelism between drill feed and spindle axis, parallelism between spindle head slideway and base, etc., are then not difficult to achieve.

At the conclusion of the acceptance tests, the deflection under the largest possible axial force acting on the drill spindle must be measured. Theoretically, it would be important to determine the inclination of the spindle, *i.e.*

the angular deviation of the spindle axis from its vertical position relative to the base. However, if this were to be measured, *e.g.* by means of a spirit level applied to the axially-loaded spindle, the result would be unreliable. Under practical drilling conditions the drill produces a hole in accordance with the spindle position. If the spindle is axially loaded for test purposes, its nose will be held in its original direction by the loading device, which means that inclination would be at least partly prevented. According to the amount by which the spindle protrudes from the headstock it will be rather buckled than inclined, and a measurement of its inclination by means of a spirit level will be useless. For this reason the increase in the distance between spindle nose and base plate, under the action of the axial force, is measured.

This measurement should not be carried out during drilling operations. The axial pressure during drilling depends upon the rake angles of the drill, the dimensions of its cross edge, the hardness of the material being drilled, etc., and it may vary by 20 per cent or more. This means that the magnitude of the axial force exerted during the deflection test would be uncertain. The test is therefore carried out with a stationary drilling spindle. A load cell is placed on the table or the base plate under the spindle nose, and the spindle is then fed down by hand until the gauge indicates the required axial pressure. Any measuring device of simple construction can be used for this purpose.

It is advisable for the manufacturer to specify the maximum axial pressure for which the machine is designed. It is also possible for the maximum drill diameter to be specified with which holes can be drilled into solid material having an ultimate tensile strength of approximately 30 to 40 tons per square inch. Recommended feed values are given in Fig. 27. If high-speed steel drills are used these

Diameter of Drill		Proposed Feed Rate		Pressure*	
mm.	inches	mm./rev.	inch/rev.	kg.	lb.
5	$\frac{1}{16}$	0.10	0.004	100	220
10	$\frac{1}{8}$	0.18	0.0072	200	440
15	$\frac{3}{16}$	0.24	0.0096	350	770
20	$\frac{1}{4}$	0.29	0.0116	550	1,210
25	$\frac{1}{2}$	0.33	0.0132	750	1,650
30	$\frac{1}{8}$	0.37	0.0148	950	2,090
35	$\frac{1}{4}$	0.40	0.016	1,200	2,640
40	$\frac{1}{2}$	0.42	0.0168	1,400	3,080
45	$\frac{1}{4}$	0.44	0.0176	1,650	3,630
50	$\frac{1}{2}$	0.45	0.018	1,850	4,070
55	$\frac{2}{8}$	0.47	0.0188	2,100	4,620
60	$\frac{2}{4}$	0.48	0.0192	2,300	5,060
65	$\frac{2}{4}$	0.49	0.0196	2,550	5,610
70	$\frac{2}{4}$	0.50	0.02	2,750	6,050
75	$\frac{3}{4}$	0.51	0.0204	3,000	6,600

Fig. 27. Axial Drill Pressures when Drilling Open Hearth Steel (Tensile Strength of from 50 to 60 Kg. per Square Millimetre. Approximately 30 to 40 Tons per sq. in.)

\* Drilling pressures, from 20 mm. ( $\frac{1}{2}$ -inch) in diameter upwards, apply to pointed drills. The length of cross edge remaining after pointing the drill is 10 to 12 per cent of the diameter, the larger value applying to the smaller, and the smaller value to the larger diameters.



feed values can be maintained in continuous production. It may, however, be necessary to reduce these feed rates in practice if the stiffness of the workpiece, the required smoothness and accuracy of the holes to be drilled or other factors require it. The specification of the maximum drill diameter does not imply that it would be impossible to drill even larger diameter holes into solid material. In such cases, however, smaller feed rates than those specified would have to be employed in order not to exceed the permissible axial force. Furthermore, it is not advisable to combine the maximum drilling capacity of a machine with a very high feed rate as specified in Fig. 27. The production engineer will usually refrain from overloading expensive large diameter drills, and if a hole of the maximum possible diameter has to be drilled, the speed of the operation is of little importance. For the actual test it is best to specify the maximum permissible axial force, as safety devices prevent this being exceeded in practice.

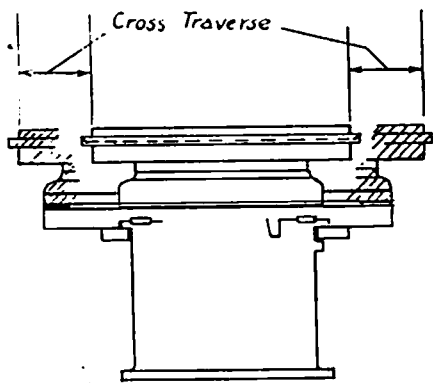

Fig. 28. Table that is Shorter than its Slideway by an amount equal to the Cross-traverse of the Table

The Test Chart for universal-joint multiple drilling machines concerns two main types, *i.e.* machines with adjustable spindle head and machines with adjustable work table. The tolerances for the spindles of such machines cannot be as tight as those specified for upright drills, because their spindles are guided in one bearing only, with the inclined thrust of the universal-joint shafts acting at the top of the spindle. If the spindles are guided in fixed bearings on an interchangeable cluster plate, rather than in adjustable brackets, the tolerances can be much tighter.

A high degree of accuracy is required for horizontal boring machines. Very close limits are therefore specified in Test Charts 35 to 38 to suit the various sizes of these machines. If, on smaller machines, the outer stay bearing is moved automatically together with the headstock, the vertical adjustment must be carefully tested with regard to the alignment between the stay support bearing and the main spindle. During the test, the headstock and the support bearing must be moved from the low position upwards in order to eliminate backlash in bevel gears and screw threads. Heavy types of horizontal boring machines with movable uprights are usually equipped with separate work tables. For this reason, the alignment of the main spindle is tested in relation to the movable upright and the

bed rather than to the work table. The machines shown on Charts 35, 36 and 38 are equipped with tables which are shorter than their slideways by an amount equal to the length of the cross traverse of the table (Fig. 28). In some designs the length of the table is equal to that of the slideway, and a longer cross traverse movement is thus possible (Fig. 29). In such cases it will, however, be difficult to maintain the tolerances, specified on Charts 35, 36 and 38, for the permissible inclination of the table during its cross traverse movement.

If a machine can achieve the working accuracies specified in the top left hand corner of page 83, it will be able to perform the required work without heavy boring fixtures, guiding bushes, etc. It is wrong to assume that the horizontal boring machine provides only the driving gear for a spindle which is best connected to the tool by universal joints in order to avoid errors caused by faulty

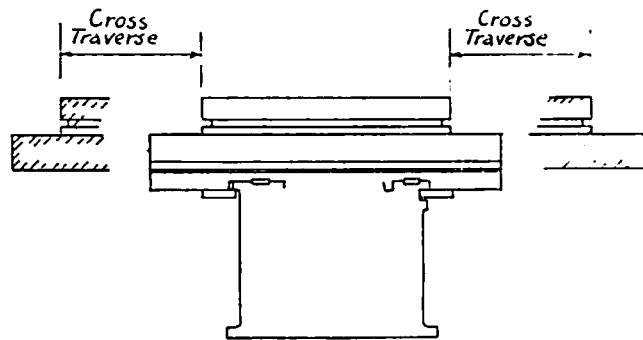

Fig. 29. Table with Length equal to that of the Slideway

spindle bearings, and to leave the accuracy of the operation to the guiding devices in a boring fixture.

#### Planing, Shaping and Slotting Machines, Tables 41-44

The extremely close tolerances for long planing machines are useless unless the machines are very carefully erected and installed and subsequently checked and re-levelled periodically. Planing machines for work of highest precision should not be grouted on a solid foundation but mounted on adjustable wedges so that they can be re-levelled every two to four months.

The accuracy which is today obtainable with shaping machines is of a very high order, and these machines are often used in preference to milling machines because of the simplicity of the tools employed.

#### Power Presses, Punching and Shearing Machines, Tables 51-53

Power presses and punching machines are grouped into one-sided open type and double-sided frame type machines. The tolerances of open-sided presses must be so chosen that the frame is straightened out under the acting forces. Due consideration has also been given to the various sizes of such machines.

## ACCEPTANCE TESTS AND MAINTENANCE OF MACHINE TOOLS

The acceptance test of a new machine tool in the manufacturer's works is carried out by experienced fitters and inspectors who know every component and who have co-operated in the manufacture of components, sub-assemblies and finally the complete machine. These men know how to use measuring instruments and how to assemble the machine in such a manner that the manufacturing tolerances of individual components have a compensating and not a cumulative effect as far as the accuracy of the whole is concerned. Similarly, the user sends a representative who is capable of carrying out acceptance tests of a machine. This man also knows when he must insist on rigid adherence to the specified limits and when he may allow relaxations in debatable cases, as long as the machine produces workpieces within the required limits of accuracy. Complaints about awkward inspectors may have occurred when the specifications were first introduced but they have soon disappeared. Manufacturer and customer have learned to use the specifications both for inspection and test purposes, and work can proceed smoothly.

An additional field of application is the current inspection of machine tools during their use in production, and after maintenance and repair work has been carried out.

The machine-tool user expects the machine to produce accurate workpieces not only when it is new but throughout its working life. A machine tool must be able to produce workpieces within specified limits without the need for special professional skill on the part of the operator to compensate for faults of the machine. For this reason the wear of the machine must not exceed certain limits, it must be watched, and parts which are faulty, due to wear or other damage, must be replaced or repaired without delay. Repair and maintenance work must be carried out in accordance with preventive planning rather than by default. This is important from the point of view of planned steady production and it eliminates costly delays which would otherwise occur when an important machine tool breaks down. Emergency repairs are, of course, occasionally unavoidable but the experience gained should be used to prevent their recurrence.

The maintenance of the machine tool includes:—

1. Checking the accuracy of the finished workpieces.
2. Preparation of materials and component parts necessary for repair work, including bought-out parts. Any repair work must be carefully planned beforehand.
3. Instructions to machine shop foremen and operators in order to ensure correct use of the machines.
4. Overhaul or rebuilding of the machine tool.
5. Emergency repairs.
6. Estimates of maintenance and repair cost.

After a certain working life, natural wear of the various parts of a machine tool will cause errors in the workpieces produced. If this is noticed in time, it can be corrected either by making use of adjusting devices or by scraping, fitting, etc., without interfering with the productivity of the machine. When the machine has been in operation for a

certain period, or if it has been over-strained, it must be subjected to a thorough overhaul, preferably in accordance with a definite time schedule.

Such an overhaul can either be restricted to replacing or repairing worn or damaged parts, or it can be used for modernising the machine by "rebuilding" it. In the latter case, the machine tool engineer would have to ensure that after rebuilding, the machine will meet up-to-date demands of power, speed and productivity. New bearings, improved main spindles, new gears, better lubrication, etc., will help in making a modern machine out of an old one. It is necessary to consider not only the methods of maintenance and repair but also the people who carry out the work involved. The head of the maintenance shop should be responsible to the works manager and should be given full authority to carry out the work required for keeping the machine tools in the factory in good condition. Foremen, fitters and operators must be carefully selected and trained for the specialised work which they have to carry out. They need the ability to watch and observe, they must be reliable and able to carry out precision work. They must have the skill to dismantle a mechanism and the sound judgment and experience which will enable them to decide on action to be taken. The maintenance shop must not be the department to which worn-out and useless men are demoted. The men in the maintenance shop must be able to carry out high-precision work and to detect weaknesses in design and their elimination.

The measuring and testing equipment used in the maintenance shop is practically identical with that used for acceptance tests. In addition, scrapers, surface plates, straight-edges, etc. must be available as well as special equipment necessary to suit the requirements of particular machines which have to be repaired.

In small machine shops, inspection and repair are usually carried out by the same men. In larger shops, an inspector will work side-by-side with the workmen who carry out the repair work. It will also be advisable to create repair gangs of operators who are each responsible for certain types or groups of machine tools. Each gang will then consist of specialists with the knowledge of weak spots of the machine under their care which have to be watched.

Today there exists an industry which does nothing but rebuild machine tools. In their workshops not only standard but also special machines are dealt with in large numbers, and the experience gathered produces a staff of expert maintenance men, repair fitters and inspectors.

The periodic examination of bearings for gear-cutting machines, of slides for the diamond-dressing devices for grinding machines, the examination and testing of hydraulic drives for grinding, planing and milling machines, are examples of detail maintenance work required for keeping important machine elements in an efficient working condition. Such work can be done during the lunch break or in the evening without interfering with the output of the machine.

A complete overhaul or even rebuilding of a machine tool is advisable after a long period of service. A typical

works order for the overhaul of machine tools in the factory of a British motor manufacturer is shown here:—

MACHINE No. ....  
 Date .....  
 JOB No. ....

Machine Overhaul Sanction Form

Description of machine .....

Date purchased ..... Price .....

Present book value ..... Present market value .....

Cost of a new up-to-date machine of same type .....

A brief statement to denote the relative production value of a new machine of same type.....

Hours in use.....

Repairs for last two years cost .....

Repairs for current year cost .....

Last overhaul cost..... Date.....

Special reason for overhaul.....

Extent of overhaul proposed .....

Estimated cost .....

Remarks.....

Length of time machine can be released for overhaul.....  
 .....(obtained from progress department).....

Overhaul sanctioned.....

It is interesting to note how technical and economic considerations have been weighed against each other.

Apart from the regular general inspection of the machine tools, immediate steps must be taken when faulty workpieces are produced by a machine, *i.e.* when machined dimensions lie outside the specified limits (emergency repair). In such cases the accuracy and performance of the machine must be tested without delay. Faults can be eliminated only if the causes of errors are known. In order to carry out such a test the following information must be available:—

1. The required accuracy of alignment, direction of motion and shape of those parts of the machine tool which affect its performance.

The basic principles for maintenance, repair and rebuilding of the machine tools are identical with those for their manufacture. The Test Charts provide, therefore, the required information. Their practical value lies in the fact that they not only show the type and location of errors but also indicate the permissible limits within which these have to be kept. Practical rectification is possible only after errors of geometrical shape have been determined. The machining tolerances of the workpieces, which are stated at

the end of a Test Chart, are in accordance with standard systems of limits and fits.

2. The best methods of carrying out the required measurements and of using the necessary equipment. The application of the measuring equipment and the actual execution of the measurements will be discussed in the following chapter.

Present-day machine tool manufacturers specialise on a limited number of types of machine tool, and sometimes on only one type. Some produce only lathes, others specialise on the manufacture of milling machines, grinding machines or radial drilling machines, and each manufacturer is an expert in the production and testing of his type of machine. He must, however, use other machine tools in his workshops, perhaps even in greater number than machines of the type he is producing. He is, therefore, as much a customer and user of these other machines as any other machine shop which has no direct connection with the manufacture of machine tools. For this reason the problem of systematic checking, current maintenance and thorough overhaul of machine tools is of major importance for all engineering workshops. Manufacturers cannot afford to use only the latest and most up-to-date machines, and have to give serious consideration to the question: when is a machine tool old? The answer has to be considered from both the technical and economic viewpoints. It must be accurately checked by performance figures and not backed by guesswork based on general experience. The necessary performance figures are provided by the tests specified in the Test Charts. These describe the general layout of the tests and the tolerances for the accuracy of the various parts of the machine. In this chapter additional information is provided as to how the operator has to apply the measuring equipment.

The general procedure is laid down along the following lines:—

1. The machine is installed and carefully levelled by the proper use of a spirit level.
2. Where necessary the straightness, flatness, parallelism and quality of the guiding and bearing surfaces of beds, uprights and base plates are tested.
3. The main spindle, one of the principal elements of the machine, is tested for true running, axial slip, and location and position of its axis relative to other axes and surfaces.
4. The movements of other main parts of the machine are checked.
5. Working tests are carried out in order to determine whether the machine as a whole produces workpieces within the specified limits of accuracy.

This general procedure is applicable to all types of machines, and the main principles can be described, therefore, with reference to a few typical machines, *viz.* lathes, milling machines, cylindrical grinding machines and radial drilling machines.

This description should assist the foreman and the experienced craftsmen in a repair shop in carrying out the tests in a satisfactory manner. In large organisations a qualified inspector will supervise the correct application of the test specification, and in other cases the foreman can do this job. If, however, the same person is in charge of the execution and inspection of the work, especially when delivery schedules and cost requirements are tight, this may lead to conflicts of conscience. These can best be avoided

by the inspector being directly responsible to the works management and not to the foreman.

The works management should expect first and foremost good quality overhaul, second place being given to the requirements of speed and cost. For this reason friction amongst personnel in a maintenance shop must be avoided, and this can best be achieved by simple and unambiguous instructions for measurements and tests. If rebuilt machines are to compete with new machines in a workshop, their performances must be of comparable quality.

### Test Specifications

A. The accuracy with which the machine has been manufactured.

I. Installation and levelling of the machine.

II. Testing the quality of slideways and locating surfaces.

III. Testing the accuracy of the main spindle and of its alignment relative to other important parts of the machine.

B. The accuracy of the workpieces produced on the machine.

C. Power requirements.

### A. I. INSTALLATION AND LEVELLING OF THE MACHINE

Measurements are carried out with the spirit level the sensitivity of which has to be in accordance with the required accuracy (see page 10).

#### Tolerances for straightness and evenness

When the straightness of edges or of movements and the evenness of surfaces are tested, the tolerance indicates the permissible deviation from a theoretically exact straight line or accurate plane. If the horizontal plane is taken as datum, the measurements can be carried out either with a spirit level or by means of a measuring point touching the surface of a liquid. It is also possible to use a tracer instrument and to compare either horizontal or sloping surfaces with accurate planes the shape and position of which are known. The support of the tracer instrument can be moved along the datum plane or it can be moved along the surface to be measured, the tracer moving in this case along the datum plane. For long slideways, the test with wire and microscope has proved useful (see Fig. 8). The tolerance concerning straightness or evenness indicates the amount by which the reading on the measuring instrument or on the microscope is allowed to vary. When the spirit level is used, the deviations have to be determined by means of calculation or by plotting the results over the full test range.

In general, the deviation from straightness may occur in the specified plane or, if no plane is specified, in any plane. When evenness is tested, the deviation may occur normal to the surface tested, causing either concavity or convexity. If the deviation is permissible in only one direction, this must be clearly stated; for instance, 'tolerance 0.015 millimetre in 1,000, surface only concave'.

#### (a) Levelling the Lathe Bed (Test Charts 11-13, Fig. 1)

1. Longitudinally.

2. Transversely.

During the test of short machines the carriage must be in the middle of the bed. In the case of long beds with more than two legs it must be between two legs.

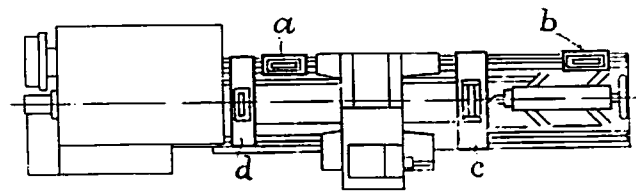

Fig. 30. Levelling the Lathe Bed

1. A spirit level (scale value 0.04/1,000) is best put first on the rear slideway (i.e. the slideway opposite the operators' side). This slideway is usually plane whilst the front slideway may be intentionally convex. By checking positions *a* and *b* of the rear slideway (Fig. 30) and repeating the measurements for the front slideway straightness of the beds can be determined.

2. It is advisable to check the levelling in the transverse direction simultaneously with 1. This is done by means of a second spirit level alternatively placed in positions *c* and *d*. A  $\pm$  twist is not permissible, because the sliding surface of the carriage would not be properly supported by twisted slideways.

The above tests make it possible to ensure that the four corners of the bed lie in a horizontal plane, and this plane is the datum for all following measurements. The actual profile of this plane between the four corners is determined when the slideways are tested (see II (a)), and these tests are usually carried out immediately after the four corners have been levelled.

#### (b) Levelling the Table of Horizontal and Vertical Milling Machines (Test Charts 1-3)

1. Longitudinally.

2. Transversely.

The table is brought into its middle position in order to prevent tilting in the slideways.

1. The spirit level is placed in the centre and at both ends of the table (positions *a*, *b*, *c*, Fig. 31). The deviation of the air bubble in a plus or minus direction is recorded. Deviation in both directions is permissible as the table surface is not a slideway.

2. This is carried out in a manner similar to 1 (positions *d*, *e*, *f*, Fig. 31).

#### (c) Levelling the Grinding Machine Bed (Test Chart 21)

1. Longitudinally.

2. Transversely.

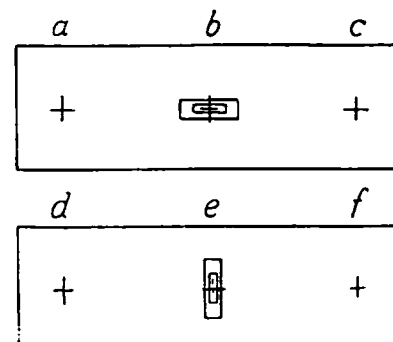

Fig. 31. Levelling the Table of a Milling Machine

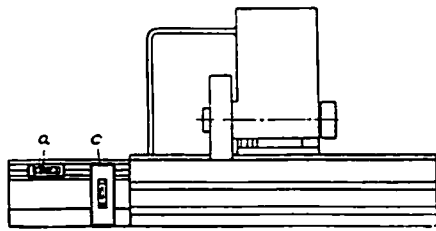

Fig. 32. Levelling the Bed of a Grinding Machine

1. The spirit level is placed longitudinally at one end of the bed (position *a*, Fig. 32). The table can then be moved to the other end and the spirit level placed in position *b* (see Fig. 30).

2. The spirit level on a measuring bridge is placed transversely on the bed in positions *c* and *d* (Fig. 32, see also Fig. 30).

The table can be moved to its extreme right-hand position for measurements *a* and *c*, and to its extreme left-hand position for measurements *b* and *d*. It is, however, advisable to remove the table and to put the spirit level on the slideways at intervals of about 300 millimetres (12 inches).

(d) *Levelling the Base and Testing the Position of the Column of a Radial Drilling Machine (Test Chart 34)*

1. Levelling the base plate (Fig. 33A). The radial arm and drilling head are in their middle positions. A straight-edge about 1,000 millimetres (40 inches) long is placed diagonally on the base plate, and a spirit level in the middle of the straight-edge. Convexity of the base plate is not permissible.

2. Testing the column (Fig. 33B, 33C) with the radial arm and the drilling head in the same position as before. The column must be at right angles to the base. The Vee-shaped face of the frame spirit level is held firmly against the front and side of the column. Deviation from the vertical is only permitted towards the base plate. The deviation indicated by the spirit level must not exceed the permissible value in any position around the column into which the radial arm may be turned, especially if the base plate has an angular or cruciform shape.

A. II. TESTING THE QUALITY OF SLIDEWAYS AND LOCATING SURFACES

Although definite standards for the surface finish of slideways have not yet been established, measurements

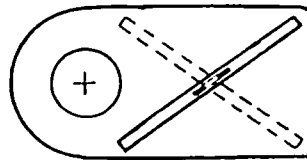

Fig. 33A. Levelling the Base

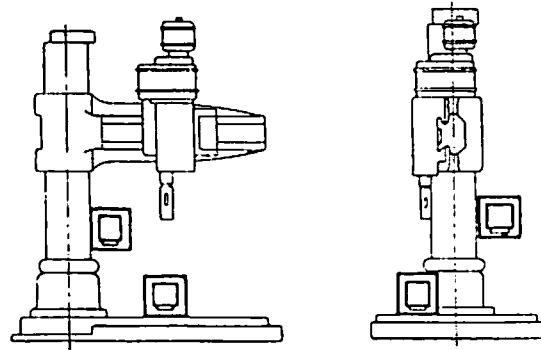

Fig. 33B and 33C. Checking the Column

concerning flatness, straightness and parallelism of the principal machine ways have been introduced successfully.

One method of checking scraped or ground surfaces consists in passing the plunger of the dial gauge over the surface to be tested. The dial-gauge support must have a locating surface of generous dimensions and must be guided along a good datum surface or edge (surface plate or straight-edge). The radius of the hardened plunger stylus should be about 1.5 millimetres (0.06 inch). The plunger of the dial gauge is then moved directly over the surface to be tested along a series of parallel lines. The pointer indicates the peaks and valleys of the surface without being deceived by the mottling of the sliding surfaces. This method determines the average heights and depths of peaks and valleys. The valleys of a well-scraped or ground surface should lie not more than 0.002 to 0.005 millimetres (0.00008 to 0.0002 inch) below the main bearing area.

The waviness meter developed by S. A. Tomlinson (Fig. 34) also measures and records waviness. The tracer *a* is a ball,  $\frac{1}{16}$  inch diameter, fitted to the bottom end of a vertical rod *b*, which in turn passes through a hole in the base plate *c*. The latter rests on the surface to be tested. The rod *b* is vertically adjusted by means of the screw *d* until the ball *a* protrudes approximately 0.003 inch below the face of the base plate *c*. This adjustment is easily carried out with the help of a thin shim of paper. When the base plate *c* is now pressed against the surface to be

Fig. 34. Waviness Meter (S. A. Tomlinson, N.P.L.)

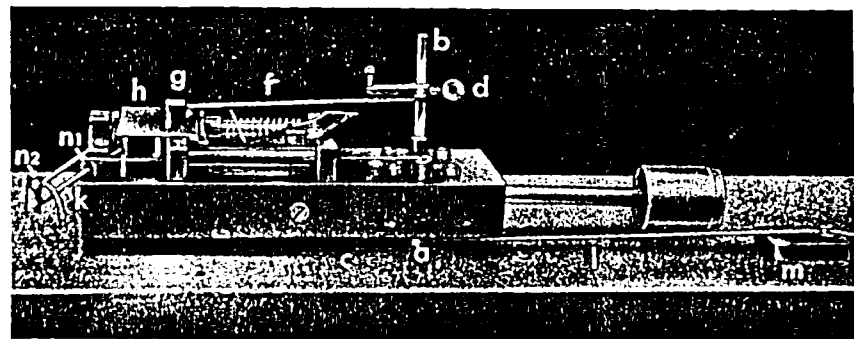

tested, the rod *b* is moved by an amount equal to the height or depth of the waviness. The axial (vertical) movement of the rod is converted into a rotational movement which actuates the recording pointer *f*. This carries at its free end a scriber *g* for scratching a smoked glass plate *h*. The glass plate is automatically moved at right angles to the movement of the scriber by an amount proportional to the distance along which the instrument is moved by hand over the surface to be tested. The smoked glass plate carrier *j*, sliding on two cylindrical guides, is moved by rotation of the lever *k*. The lever *k* is moved by means of a cord *l*, the other end of which is fastened to a brass block *m*. The brass block *m* is in turn fixed to the tested surface by suction pads, Plasticine or similar means. The cord can be attached to the lever *k* either at *n*<sub>1</sub> or *n*<sub>2</sub> thus producing a traverse of one or two inches respectively. The instrument is moved by hand over the tested surface. If this movement has to be exactly along a straight line, a straight-edge can be used for guiding purposes. The small record scratched into the smoked glass plate is magnified by photographic means, the usual magnification being 50:1.

#### (a) Lathe Bed

The bed must be straight longitudinally (Test Chart 11, Figs. 1a and 1b). In the case of beds up to three metres (10 feet) long, it is sufficient to place a spirit level on the slideways; if necessary an intermediate block, see Fig. 26,

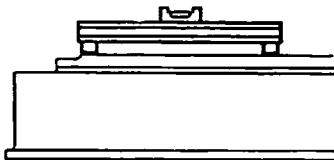

Fig. 35.  
Level on Bridge

or a bridge piece, Fig. 35, can be employed. The base of the spirit level must always be parallel to the direction of the slideways. The straightness of the latter is checked by placing the spirit level at intervals of about 300 millimetres (12 inches) along the whole length of the bed. The difference between this test and the levelling of the four corners (see page 26) lies in the fact that for the straightness test the spirit level readings are taken in several positions along the bed.

For machines of more than three metres (10 feet) between centres, other methods are used for testing the straightness of the slideways, e.g. the taut wire, the telescope, the auto-collimator, comparison with a long straight-edge, etc. (see page 13). The tolerances for the front and rear slideways of the lathe differ. The front slideway has to be convex; the displacement of the bubble should always be directed towards the centre of the slideway (*i.e.* to the right coming from the headstock end and to the left coming from the tailstock end, see Fig. 13). The rear slideway is usually flat and for this reason is suitable for use as the starting surface for all measurements. The straightness and surface quality of the tailstock slideways as well as their parallelism (Test Chart 11, Fig. 3) with the slideways for the saddle is best tested with a dial gauge clamped to the saddle (Fig. 37) and measuring both surfaces of the Vee. The full length of the slideways is tested, including the bridge piece which covers the gap, if present. The plunger of the dial gauge indicates any small depression in the surface which might be caused, for instance, by mottling. These surfaces are relatively small in relation to the load to which they may be subjected. They may,

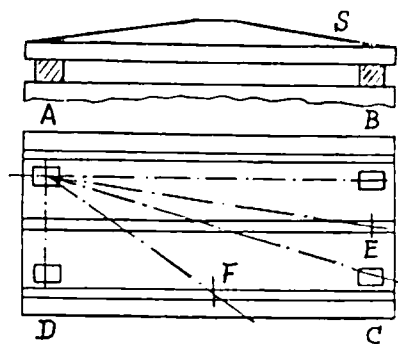

Fig. 36. Checking Flatness of Table

therefore, be subject to considerable wear, and their quality is of great importance. If intermediate blocks are used when checking the parallelism between saddle and tailstock slideways (see Fig. 26), the quality of the scraped surface will not be indicated by the dial gauge.

#### (b) Milling Machines

The table should be flat in the longitudinal and transverse direction (Test Chart 1, Fig. 3). This is tested by means of a spirit level (scale value 0.04/1,000 millimetres; or 0.0005 inches/foot) which is placed directly on the table at intervals of 100 millimetres (4 inches). The deviations of the bubble at various points are indications of the table surface quality. It is advisable to record these deviations in a sketch.

In this case the measurement using the spirit level combines the levelling of the machine with a test of the table flatness. The flatness of the table can also be checked by means of a straight-edge placed on equal slip gauges or parallel blocks which rest on the table (Fig. 36). Variations in the gap between the straight-edge and the table are measured with a precision dial gauge, the support of which rests on the table whilst its plunger is moved along the bottom face of a straight-edge. The straight-edge and the parallel blocks are moved from the original datum position *AB* (Fig. 36) to positions indicated by the dotted lines (*C, D, E, F*, Fig. 36) and comparative measurements are taken. This method is very accurate but slow, requiring great care and an extremely thorough inspector.

On the flatness of a milling-machine table depends the quality of the surface milled on the machine. The workpiece has to be clamped tightly to the table. If the table has a wavy surface and is stiffer than the workpiece the latter will be distorted by the clamping forces. After the

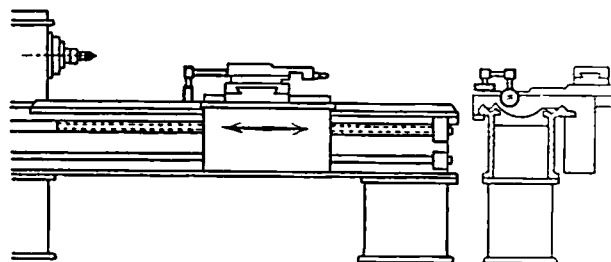

Fig. 37. Acceptance Test for Guideways

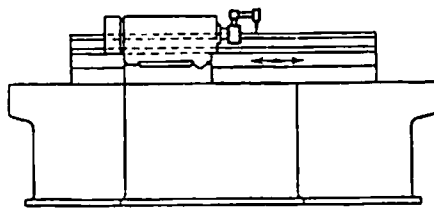
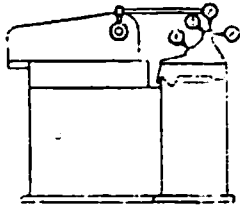

Fig. 38. Grinding Machine Test

milling operation is completed and the clamps are removed, the workpiece will spring back causing the milled surface to lose its flatness. It is important, therefore, that workpieces used for test cuts are sufficiently stiff to resist such distortion (see Test Charts, pages 42 and 49).

(c) Grinding Machines

The straightness of grinding machine slideways is tested when the bed is levelled in the manner described on page 26. Long beds have to be supported at intervals of not more than 800 millimetres by means of wedge pieces which rest on the foundation. Sound foundations are essential for all grinding machines. For long slideway grinding machines, cast-iron base plates grouted on a concrete foundation are often used. The slideways of cylindrical-grinding machines are not as unfavourably loaded as those of the lathe. The grinding forces are small and the long grinding table carrying headstock and tailstock, which are not heavy, distributes the load. The straightness of the slideways and of the locating faces for headstock and tailstock has to be carefully checked (Fig. 38). The swivelling table must be in the position for cylindrical grinding. The dial gauge is fixed to the bed with the plunger touching the locating face under test. The table is then moved along its slideways and readings of the dial gauge are taken (Test Chart 21, Fig. 2).

(d) Radial Drilling Machines

The straightness and flatness of the base plate, the surface of which serves for locating workpieces or drilling jigs, is tested longitudinally and transversely either directly with a long-base spirit level (length of base not less than 250 millimetres, or 10 inches) or with the help of a bridge piece as indicated in Fig. 35 (distance between the legs, 300 to 500 millimetres; or 12 to 20 inches).

The radial arm and drilling head are moved into their middle position. The bridge and the spirit level are placed along three parallel longitudinal lines *a*, *b* and *c*, Fig. 39A on the base plate. On each line, readings are taken every 300 to 500 millimetres (12 to 20 inches).

In a similar manner, readings are taken along three

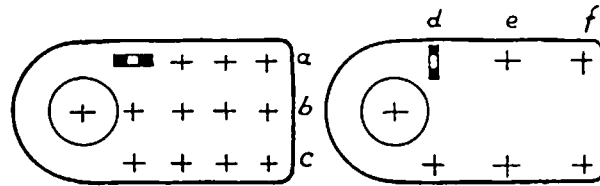

Fig. 39A and 39B. Checking Flatness of Base

parallel transverse lines *d*, *e*, *f*, Fig. 39B. As the base plate has to be concave in both directions, the deviation of the air bubble changes from plus to minus over the measured length. Long bridge pieces would hide the shape of the surface. Short bridge pieces are preferable because they avoid this drawback and also eliminate the influence of small irregularities which would affect the measurement if the spirit level were placed directly on the base plate.

AIII. TESTING THE ACCURACY OF MAIN SPINDLES AND OF THEIR ALIGNMENT RELATIVE TO OTHER IMPORTANT PARTS OF THE MACHINE

These tests concern:—

1. True running of
  - (a) The centre (Fig. 40A);
  - (b) The internal taper;
  - (c) Cylindrical locating spigots, external tapers, etc. (Figs. 40B to 40D).
2. Axial slip.
3. Alignment between spindle axis and other axes.
4. Parallelism between spindle axis and slideways.
5. Perpendicularity between spindle axis and slideways.

It may be repeated here that, in all tests concerning running conditions and alignment of the main spindle, the machine must be at its working temperature, as otherwise the spindle will not be in its normal position in the bearings

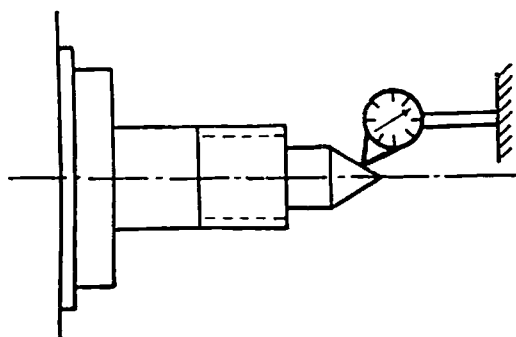

Fig. 40A. Checking the Centre

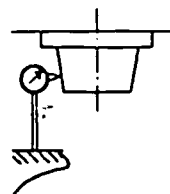

Fig. 40B. Checking a Taper

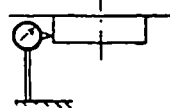

Fig. 40C. Checking a Cylindrical Spigot

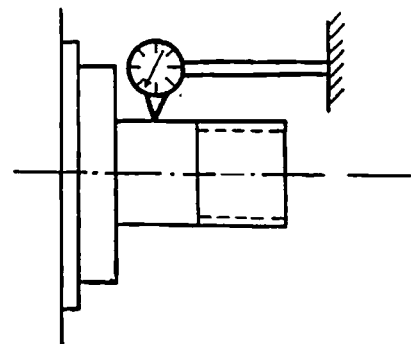

Fig. 40D. Checking a Cylinder

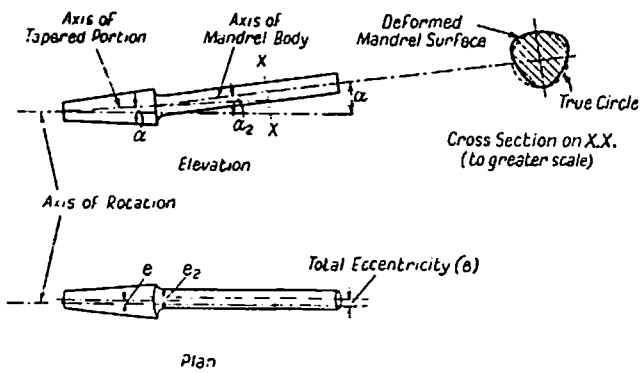

Fig. 41. Sources of Error in Rotating Mandrels

### 1. True running

Three source of errors have to be covered and are often measured simultaneously (Fig. 41); these are :

- (i) Inclination of the spindle axis in relation to the axis of rotation (angle  $\alpha$ )
- (ii) Eccentricity of the spindle axis with respect to the axis of rotation (distance  $e$ ).
- (iii) Lack of roundness of the surface tested as shown in the enlarged cross-section XX.

For all these measurements, a precision dial gauge is used, the calibration of which should be checked every few months by means of slip gauges.

The tolerance specified for true running indicates the permissible movement of the dial-gauge pointer during one complete revolution of the machine spindle. In order to evaluate this measurement, the axial distance of the dial-gauge plunger from the spindle nose has to be clearly stated. When test mandrels are used, measurements should always be carried out at two points, *i.e.* near the spindle nose and at the end of the mandrel.

(a) The tests for true running of the centre points are usually required only in the cases of lathes (Test Chart 11, Fig. 4), and grinding machines (Test Chart 21, Fig. 4).

(b) In the cases of machines with a rotating spindle, *e.g.* lathes, grinding machines, milling machines, drilling machines, etc., a test mandrel, with a locating taper shank and a cylindrical portion, about 300 millimetres (12 inches) long, is used. The method of carrying out these tests is shown in Fig. 42. The taper shank of the test mandrel is located in the spindle taper. The dial-gauge plunger rests on the cylindrical surface of the test mandrel and readings of the dial gauge are taken while the spindle is slowly rotated. Readings are taken with the dial-gauge plunger both near the spindle nose (a) and at the end of the test mandrel (b).

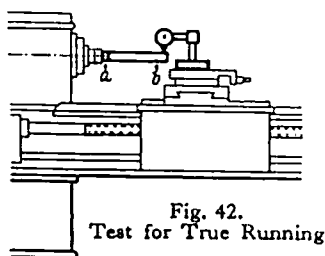
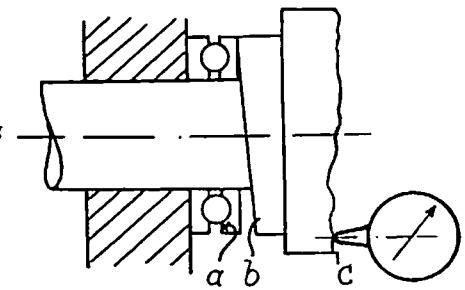

Fig. 42. Test for True Running

Fig. 43. Testing Axial Slip



(c) External cylinders or tapers (Fig. 40B to 40D) are used for locating a chuck on a lathe spindle (Test Chart 11, Fig. 5), for locating a cutter head on a milling spindle (Test Chart 1, Fig. 2a), and for locating a grinding wheel on a grinding spindle (Test Chart 21, Fig. 11a). Tests for true running are carried out by resting the dial-gauge plunger at right angles (radially) to the surface to be tested. Readings of the dial gauge are taken while the spindle is slowly rotated.

### 2. Axial Slip

If the plunger of the dial gauge rests against a shoulder face, the total error indicated may be the result of three sources (Fig. 43):

- (a) Errors in the thrust bearing.
- (b) The face of the locating shoulder is not perpendicular to the axis of rotation.
- (c) The shoulder face is irregular.

The total error indicated by the dial gauge is then  $(a) + (b) + (c)$  wherein (a) and (b) are usually large compared with (c).

If the shoulder face has been machined with the spindle in its bearings in the headstock, and if the dial-gauge plunger touches the shoulder face at the same spot at which the turning tool or the grinding wheel has acted, the dial-gauge indication would not vary at all. For this reason, all shoulder-face measurements for axial slip must be carried out at two diametrically opposite positions (Fig. 44). After the plunger is placed against the shoulder face of the spindle, readings are taken while the spindle, axially loaded against the thrust bearing, is slowly rotated. Measurements are repeated with the dial-gauge plunger resting against the shoulder face at a point diametrically opposite to that of the first measurement. The influence of the errors of the shoulder face can also be eliminated by placing the dial-gauge plunger as accurately as possible in line with the axis of rotation either against a face which is perpendicular to the axis of rotation (Fig. 45a) or against a steel ball

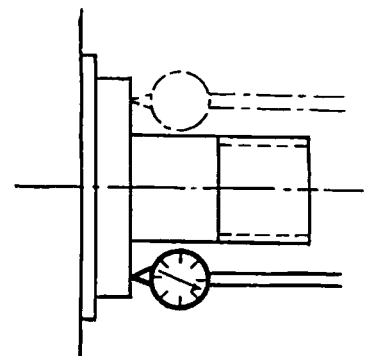

Fig. 44. Testing the Face of a Shoulder



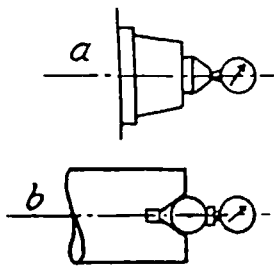

Fig. 45.  
Axial Slip of a Spindle

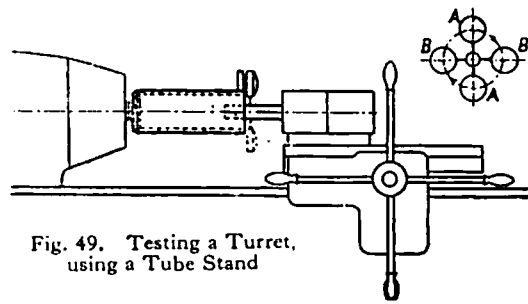

Fig. 49. Testing a Turret,  
using a Tube Stand

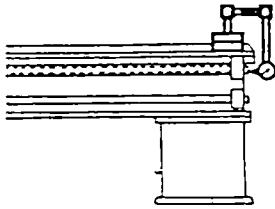

Fig. 46.  
Axial Slip of Lead-screw

which rests in the centre bore (Fig. 45b). The first method (Fig. 45a) is often used when axial slip of the spindle is measured, the second method (Fig. 45b and Fig. 46) is employed for testing the axial slip of lead-screws.

### 3. Alignment

This concerns errors of alignment between two axes or faces. It is often necessary to describe the plane in which the alignment error has to be measured. If the measurement is carried out by rotating a dial gauge about one axis in such a manner that the plunger point describes a circle around the axis of rotation (Fig. 47), the permissible deviation of the dial-gauge pointer is twice the error of alignment and may, therefore, be twice the permissible tolerance indicated in the Test Chart. An eccentricity  $T$  (Fig. 47) produces a deviation  $2T$  of the dial gauge pointer.

When test mandrels are used (see page 9) errors due to the sag of the mandrel and an additional deformation caused by the weight of the dial gauge, the plunger pressure, a slip bushing, etc., must be avoided.

Three methods are used:—

- (a) The swing-over or turn-round method (Figs. 1A and 47).
- (b) The double-mandrel method (Figs. 1B, 1C, 50 and 51).
- (c) The slip bushing method (Fig. 53).

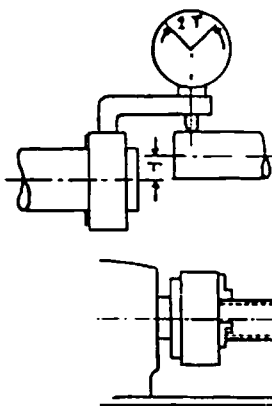

Fig. 47.  
Turn-round Reading

Fig. 48. Tubular Holder for Dial Gauge

(a) *The swing-over or turn-round method.* This has been shown and discussed in Figs. 1A, 19 and 47. The dial gauge must be of the required accuracy and the mandrel of the necessary size and stiffness. Readings are taken at  $180^\circ$  positions in the horizontal and vertical planes, and, as mentioned above, the alignment error is equal to half the difference between two diametrically opposite readings.

In horizontal readings, errors are less likely to occur than in vertical ones, as the influence of the dial-gauge weight is eliminated. In the case of vertical readings, this weight increases the pressure when the dial gauge is above the mandrel and decreases it when it is below. In the case of an accurate dial gauge the result depends, therefore, on the stiffness of its support. The supporting structure for dial gauges consists usually of joints, sliding parts, etc., which are clamped by means of screws and nuts. The diameters of the supporting bars are relatively small and the deflections are influenced by the varying lengths of these bars. For this reason, measurements from a fixed datum plane on which the dial gauge support is moved (Fig. 1C) are often substituted for trammel readings with a moving dial gauge.

If, however, the dial-gauge support can be made sufficiently stiff to keep deflections due to the weight of the gauge and the spring pressure on the plunger within given limits, the trammel reading method is useful and satisfactory. A proper support for the dial gauge is the steel tube (Fig. 48). Tests with such a tubular support have shown that the errors encountered with a 0.0001 inch dial gauge are very small, and within permissible limits as far as measurements on capstan lathes, turret lathes, milling machines and grinding machines are concerned. Calibration measurements taken with a dial gauge (weight about 8 ounces, maximum plunger pressure 4 ounces; total load, 12 ounces), mounted on a steel tube ( $3\frac{1}{8}$  inches external diameter,  $3\frac{1}{8}$  inches internal diameter, 10 inches long and weighing approximately 5 pounds) gave the following results:—

i. Deflection of the free end of the tube without dial gauge	0.000014 inch.
ii. Additional deflection (vertical) under weight of dial gauge and plunger spring pressure (12 ounces)	0.0000036 inch.
iii. Additional deflection (horizontal) under plunger spring pressure (4 ounces)	0.0000024 inch.
Maximum total vertical error (i. + ii.)	0.0000176 inch.

These deflections can be neglected. The design of the support is simple, the bore of the tube is large enough to allow even a hollow test mandrel to enter during measure-

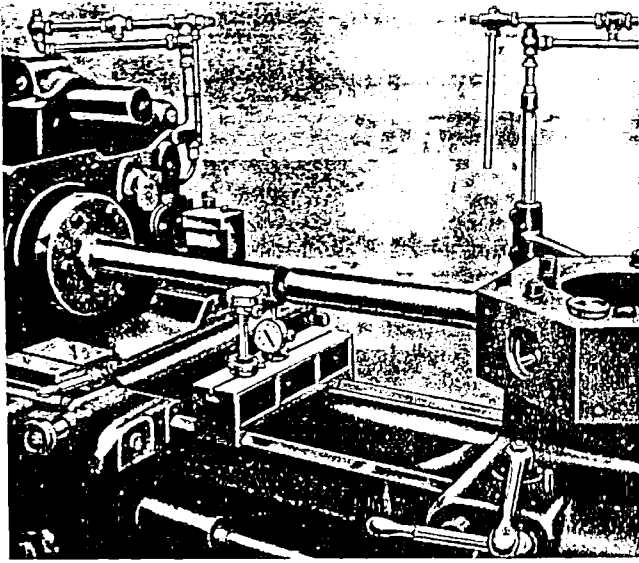

Fig. 50. Arrangement of Double Mandrel Test

ment. Fig. 49 shows the application of this method for the test of a capstan lathe where it would replace the usual double mandrel test (Fig. 50). Fig. 52 shows the method applied to a test on a milling machine where the alignment between main spindle and arbor support bearing is checked. The test mandrel is fixed in the arbor-support bearing and the dial gauge holder fastened to the spindle. The dial-gauge plunger touches the test mandrel, and the main spindle is then rotated slowly. Readings of the dial gauge are taken at four points, in the vertical plane ( $a_1$  and  $a_2$ ) and in the horizontal plane ( $b_1$  and  $b_2$ ).

The differences between the two vertical readings  $a_1$  and  $a_2$  and between the two horizontal readings  $b_1$  and  $b_2$  are equal to twice the eccentricities of the mandrel relative to the arbor support bearing in the vertical and horizontal directions respectively. The measurement is carried out in two positions *A* and *B* of the arbor support, the first at a distance of about 300 millimetres (12 inches), the second at a distance of about 500 millimetres (20 inches) from the spindle nose.

(b) *The double mandrel method (Figs. 50 and 51).* A special mandrel (*M*) is used which can be accurately aligned with the spindle axis by means of a flange and adjusting screws  $A_1$ ,  $A_2$  and  $A_3$  for tension, and  $B_1$ ,  $B_2$  and  $B_3$  for compression. Sag is reduced by using a hollow mandrel. A second mandrel *T* of exactly the same diameter (tolerance  $\pm 0.00002$  inch) is clamped into the bore to be tested. This method is used for testing the alignment of the tool holder bores in a turret head with the spindle axis

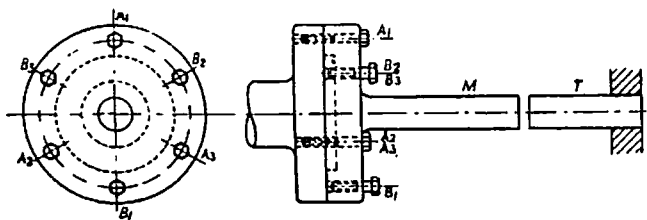

Fig. 51. Double Mandrel Test

The adjustment of the mandrel by means of the six adjustment screws is not easy and can be carried out only by an experienced and conscientious inspector. The method has several disadvantages; the distance between the spindle nose and turret head is at least 600 millimetres (24 inches) because the two mandrels must face each other and each has a measuring length of 300 millimetres (12 inches). If one mandrel (spindle) is hollow and the other one (turret head) solid, they will sag by different amounts. The spindle must be rotated until the axes of both mandrels lie in one plane at right angles to the direction of measurement.

The turret head bores are often machined in the lathe itself under its normal working conditions. For this reason the double-mandrel test must also be carried out after the spindle bearings have reached their working temperature.

(c) *The slip bushing method.* The alignment between main spindle and arbor-support bracket on the overarm of a milling machine can also be checked in accordance with Fig. 53. The plunger of the dial gauge *M* touches the test mandrel *D*. The true running of this has been checked beforehand and it has been rotated into its mean position. The bore of the bush *B* is a sliding fit on the test mandrel whilst the outside diameter of the bush *B* is a sliding fit in the bore of the bracket *A*. When the bush *B* is pushed into the bore of the bracket *A*, misalignment causes bending of the test mandrel *D*, the amount being indicated on the dial gauge. If several arbor

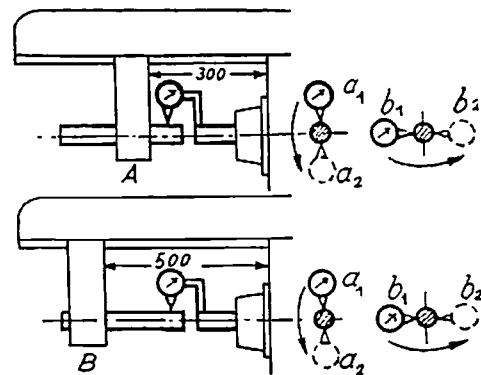

Fig. 52. Checking Spindle Alignment

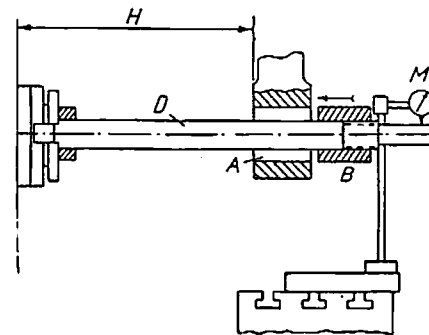

Fig. 53. Slip-bushing Method

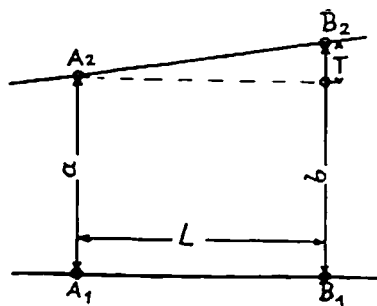

Fig. 54. Checking for Parallelism

supports are provided, the test has to be repeated with all of them.

The method, although simple, has several disadvantages. The mandrel must be very accurate and must run true. The readings are affected by errors in the main spindle bearing in a manner similar to the turn-round method. Therefore, the mean position must first be established. Measuring errors can be caused by

- i. Inaccuracy of the taper shank.
- ii. Eccentricity.
- iii. Out of roundness.
- iv. Lack of cylindricity.

Under no circumstances must an ordinary milling arbor be used as a test mandrel, because no milling arbor is sufficiently accurate for the purpose. Sag has to be considered and for this reason measurements in the vertical plane are hardly reliable. In the horizontal plane the influence of sag can be considered negligible.

The outside diameter and the bore of the bush must be concentric and cylindrical within close limits, and a tight sliding fit must exist between the bore of the bush and the outside diameter of the test mandrel on the one hand, and the outside diameter of the bush and the bore in the support bracket on the other; otherwise the test is of no value. Cast-iron or bronze bushes are too heavy and increase the sag of the test mandrel beyond permissible limits. Specially prepared light-alloy bushes should be used.

The alignment of the lathe spindle and the external diameter of the tailstock sleeve is not critical as long as the axes of the two internal tapers are in line (if the manufacture is properly controlled, however, the external diameter and the internal taper are bound to be concentric). The same applies to grinding machines. It is often easier and more accurate to check the alignment of two axes by measuring their position relative to a common datum face. (See Figs. 1b, 1c and 50.)

4 and 5. Parallelism and Perpendicularity

Parallelism between two axes, between two surfaces or between an axis and a surface is checked by measuring the distances *a* and *b* of two sets of points  $A_1, A_2, B_1, B_2$  (Fig. 54). It is usually necessary to determine the angular deviation which can also be measured by means of a spirit level or determined by relating the difference *T* to the distance *L*. Parallelism is usually measured in two planes, vertical and horizontal. Measurement in only one plane is sufficient when the position in the other plane is adjustable, (tailstocks, swivelling tables, etc.).

The tolerance for perpendicularity is specified in the same manner as that for parallelism. It is checked by means of a trammel reading or directly with a reference square.

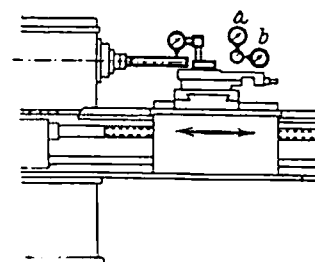

Fig. 55. Spindle

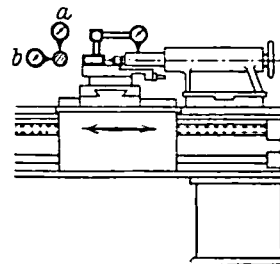

Fig. 56. Tailstock

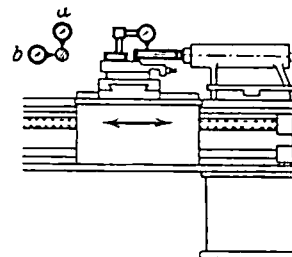

Fig. 57. Tailstock

(A) IN THE CASE OF THE CENTRE LATHE, parallelism has to be checked:

1. Between the saddle slideway and
  - (a) the tailstock slideway (see Fig. 37), *i.e.* between two surfaces (Test Chart 11, Fig. 3).
  - (b) the spindle axis (Fig. 55), *i.e.* between a surface and an axis (Test Chart 11, Fig. 8).
  - (c) the outside diameter of the tailstock sleeve (Fig. 56), *i.e.* between a surface and an axis (Test Chart 11, Fig. 10).
  - (d) the tailstock sleeve taper (Fig. 57), *i.e.* between a surface and an axis (Test Chart 11, Fig. 11).
  - (e) the lead-screw axis (Fig. 58), *i.e.* between a surface and an axis (Test Chart 11, Fig. 14).
2. Between the spindle axis and the tool rest slideway (Fig. 59). This requires a test similar to the one shown for 1 (b); (Test Chart 11, Fig. 9).

Test 1 (a) has been discussed before (see Fig. 37).

Tests 1 (b) to 1 (e) (Figs. 55 to 58) are identical in principle and are carried out in the vertical as well as in the horizontal plane. As an example, Test 1 (b) (Test Chart 11, Fig. 8), may be described in detail. The test mandrel is located in the spindle taper (Fig. 55), the dial gauge is mounted on the saddle, the plunger touching the test mandrel. The spindle is rotated into its mean position (see page 10). The saddle is moved along the mandrel by an amount equal to the reference length and the indication of the dial gauge noted. Measurements have to be repeated in the vertical plane *a* and the horizontal plane *b*. The spindle must have been running for about

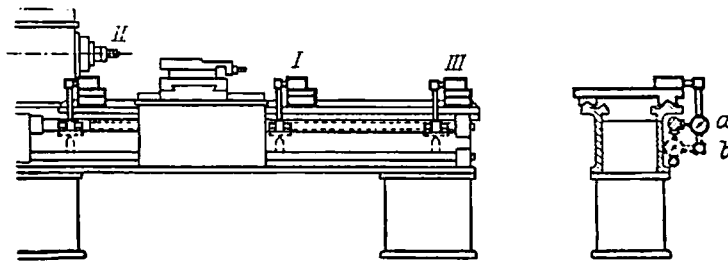

Fig. 58. Lead-screw

half an hour before the measurement is taken so that the main bearing is at its working temperature (see page 7). In view of the loading conditions during turning, the mandrel must

- (a) rise, and
- (b) point towards the tool

towards its free end.

The tailstock sleeve (Figs. 56 and 57), which cannot rotate but can be axially moved, must be clamped during each measurement, as the effect of clamping may affect its working position.

In a similar manner the height alignment of two axes is tested after each axis has already been checked for its parallelism with a common datum slideway. In the case of the lathe such tests concern the alignment of

spindle axis and tailstock sleeve taper (clamped), (Test Chart 11, Fig. 12), and

lead-screw nut (closed), and lead-screw bearings (Test Chart 11, Fig. 14).

For measuring the height alignment of spindle and

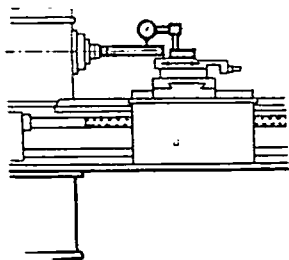

Fig. 59. Upper Slide

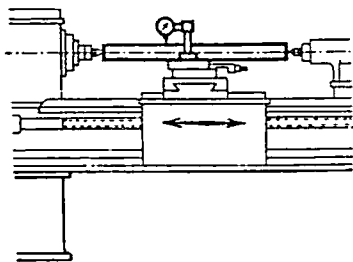

Fig. 60. Height of Centres

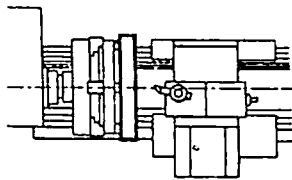

Fig. 61. Surfacing

tailstock sleeve (Fig. 60), a hollow test mandrel, 300 to 500 millimetres (12 to 20 inches) long, is held between the centres, the spindle bearing being again at its working temperature. A dial gauge is mounted on the saddle, the plunger touching the top of the mandrel. The saddle is moved along the bed and the indication of the dial gauge noted. The tailstock centre must be higher than the spindle centre.

For measuring the alignment of the lead-screw (Fig. 58), the saddle is moved to the middle of the bed and the nut closed. The dial gauge is mounted on a bridge piece which is located by the front Vee of the bed and freely supported by the rear slideway. The dial-gauge plunger touches the outside diameter of the lead-screw. The bridge piece is moved to the right (Fig. 58, I to III) and to the left (Fig. 58, I to II), and the procedure repeated both in the horizontal *a* and the vertical *b* plane. The lead-screw is also tested for true running (tolerance 0.1 millimetre—0.004 inch).

Perpendicularity between the cross-slide movement and the spindle axis can be checked either by a surfacing operation (Test Chart 11, Fig. 15) or by means of a trammel reading.

For the surfacing test, a workpiece is fixed in the chuck or fastened to the face plate and a fine finishing cut taken starting from the inside diameter. A straight-edge is then placed against two equal block gauges which rest on the

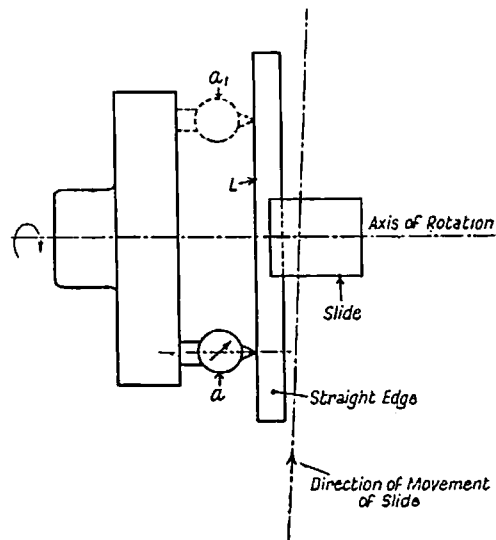

Fig. 62. Checking Perpendicularity

outside diameter of the turned face, and the distance between straight-edge and workpiece measured by means of block gauges. The turned surface must be concave (Fig. 61). This test combines an alignment test and a cutting test. It would be wrong to check the machined surface by means of a dial gauge fastened to the cross-slide because the dial-gauge plunger would traverse exactly along the path of the tool edge and would indicate a zero reading whatever the inaccuracy of alignment.

It is also possible to test the perpendicularity between cross-slide and spindle axis by means of a straight-edge  $L$  (Fig. 62), fixed to the cross-slide, and a dial gauge mounted on the face plate. The straight-edge is set exactly perpendicular to the axis of rotation of the spindle (dial-gauge reading identical in two diametrically opposite positions  $a$  and  $a_1$ ). If the cross-slide with the straight-edge is then moved along the dial gauge, alignment errors can be determined directly from the dial-gauge reading.

(B) IN THE CASE OF THE HORIZONTAL MILLING MACHINE parallelism has to be checked

1. Between the surface of the table and the spindle axis, *i.e.* between a surface and an axis (Test Chart 1, Fig. 1). The table must be flat and level.
2. Between the table surface and the direction of the longitudinal table movement, *i.e.* between two surfaces (Test Chart 1, Fig. 4). This is described as rise and fall of the table during its movement.
3. Between the direction of the cross-traverse movement and the spindle axis, *i.e.* between a surface and an axis (a) in the vertical plane (Test Chart 1, Fig. 5). (b) in the horizontal plane (Test Chart 1, Fig. 6).
4. Between the centre T-slot of the table and the direction of the longitudinal table movement, *i.e.* between two surfaces (Test Chart 1, Fig. 8).
5. (a) In the vertical plane between the overarm and the surface of the knee (see Test Chart 1, Fig. 12a). (b) In the horizontal plane between the overarm and the direction of the transverse table movement (see Test Chart 1, Fig. 12b).

The parallelism between overarm and spindle axis has been discussed previously (see Fig. 52).

1. (Fig. 63). With the table in the middle position of its longitudinal movement, a 300 millimetres (12 inches) long test mandrel is placed in the spindle taper. A dial gauge is placed on the table underneath the test mandrel with the dial-gauge plunger touching the mandrel. After the spindle has been rotated into its mean position,

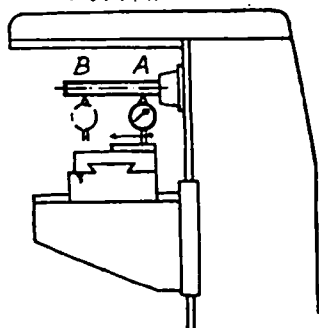

Fig. 63. Parallelism between the Surface of the Table and the Spindle Axis

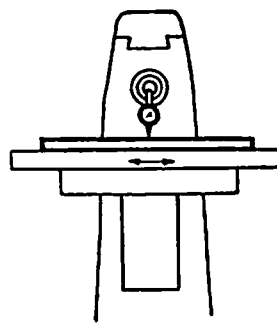

Fig. 64. Parallelism between the Table Surface and the Direction of the Longitudinal Table Movement

measurements in positions  $A$  and  $B$  are taken without the table being moved. The base of the dial gauge support must, therefore, be of sufficient length (about 8 inches) for the necessary displacement of the dial gauge to be possible.

2. (Test Chart 1, Fig. 4). From tests 3a and 3b in Test Chart 1, the flatness of the table is known. If this has been plotted, the errors of parallelism can be measured directly by moving the table under the plunger of the dial gauge. If the table is not sufficiently flat for such a measurement, a straight-edge has to be placed level on the table surface. The length of the straight-edge must be approximately equal to the total longitudinal movement of the table (20 to 40 inches).

*Testing procedure:* A straight-edge is placed on the longitudinal centre line of the table. A dial gauge is fixed to the spindle. The dial-gauge plunger is placed in contact with the straight-edge and the table is moved longitudinally and the dial gauge readings taken. (Fig. 64).

3. (Test Chart 1, Figs. 5 and 6). With the table in the middle position of its longitudinal movement, a 300 millimetres (12 inches) long test mandrel is put in the spindle taper. The dial gauge is fixed on the table with the dial-gauge plunger touching the mandrel. After the spindle has been rotated into its mean position, the table is moved transversely and readings taken

- (a) in the vertical plane (Fig. 65a);
- (b) in the horizontal plane (Fig. 65b).

4. (Fig. 66a). The vertical inner walls of the centre tee-slot must be clean and smooth throughout. Direct measurement with a standard plunger of a dial gauge is difficult and it is recommended, therefore, that an angular

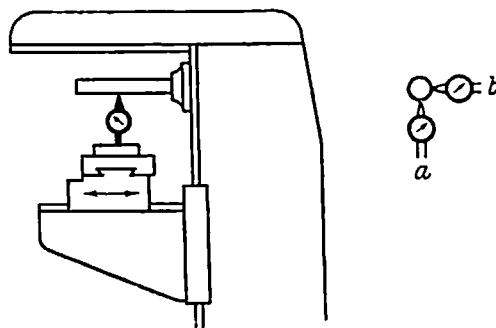

Fig. 65. Transverse Movement of Table parallel with Spindle Axis

attachment (Fig. 66b) be used, as this can be easily introduced into the slot. This enables manufacturing blemishes, which are often encountered (burrs, faulty cuts, etc.), to be detected. If an angular attachment is not available, it is also possible to place a short reference bracket (about 150 millimetres, 6 inches, long) in the slot and to go along the face of this bracket with the dial-gauge plunger during the movement of the table. However, such a reference bracket covers up local blemishes.

*Testing procedure:* (Fig. 67). The reference bracket is placed in the centre T-slot of the table. The dial gauge is fixed to the spindle taper with the dial-gauge plunger touching the edge of the reference bracket in the horizontal plane. The table is moved longitudinally, and the reference bracket is held in the T-slot by hand and readings are taken.

5. (Fig. 68). The overarm is clamped in its fully extended position. A dial gauge is placed on the knee in the two positions ( $a_1$ ,  $a_2$ ), the dial-gauge plunger touching the bottom of the overarm; readings are taken.

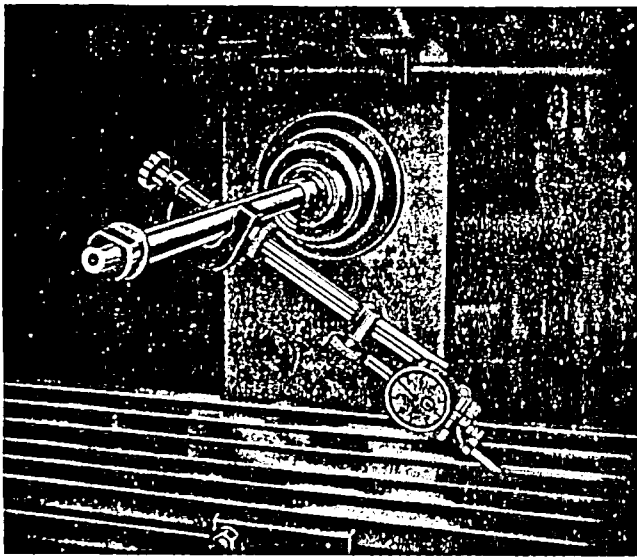

Fig. 66a. Set-up for Checking T-slots

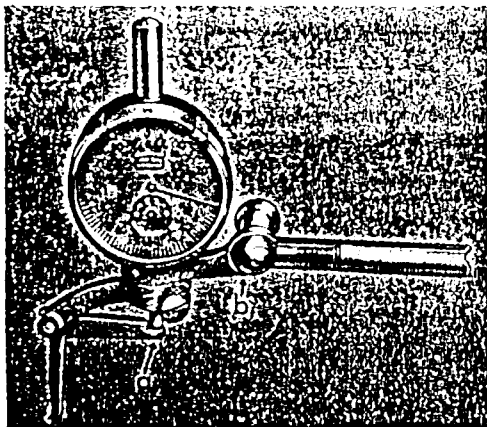

Fig. 66b. Dial Gauge with Angle-lever Attachment

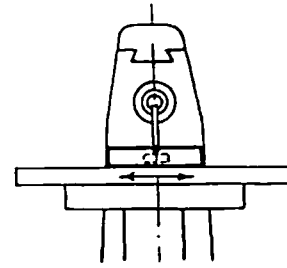

Fig. 67. Checking Parallelism of T-slot with the Table]Movement

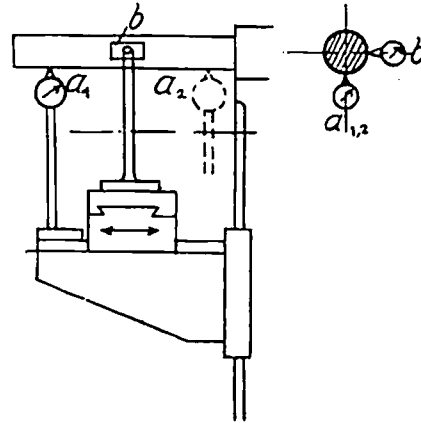

Fig. 68. Checking the Parallelism of Overarm with Transverse Movement

For the second test (Fig. 68), the dial gauge  $b$  is fixed to the table, and, with the dial-gauge plunger touching the side of the overarm, the table is traversed across and readings are taken.

If the parallelism between overarm and spindle axis in the horizontal and vertical plane is to be checked, the following procedure applies (Fig. 69). A 300 millimetres (12 inches) long test mandrel is placed in the spindle taper. The overarm is clamped in its extreme position and the dial gauge is fixed to a supporting piece which fits the overarm slideway (dove-tail or cylinder). With the dial-gauge plunger touching the test mandrel, the dial-gauge supporting piece is held by hand against and moved

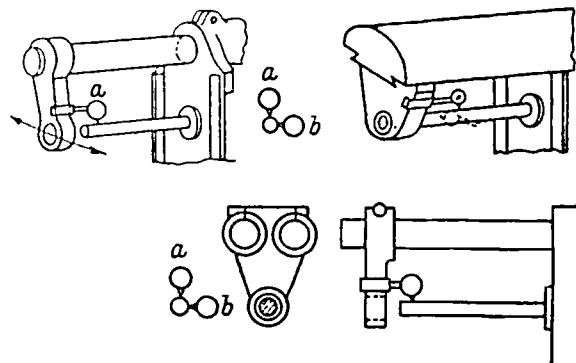

Fig. 69. Parallelism between Overarm and Spindle Axis

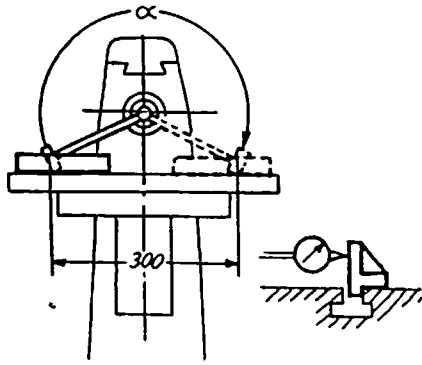

Fig. 70. Perpendicularity between the Centre T-slot and the Spindle

along the overarm slideway and readings are taken. Before the test is taken, the spindle with the test mandrel must be rotated into its mean position.

Perpendicularity has to be tested between:

1. The centre T-slot of the table and the milling spindle (Test Chart 1, Fig. 7).
2. The table surface and
  - (a) The columnway for the knee (front measurement, Test Chart 1, Fig. 9).
  - (b) The columnway for the knee (side measurement, Test Chart 1, Fig. 10).

*Testing procedure:* 1. (Fig. 70). With the table in the middle position of its longitudinal movement, a reference bracket (at least 6 inches long) is placed in the centre T-slot. The dial gauge is fixed to the spindle with the dial-gauge plunger touching the reference bracket in the horizontal plane. The reference bracket is shifted from one end of the table to the other and trammel readings are taken.

2. (Figs. 71A and 71B). With the table in the middle position of its longitudinal and cross-traverse movement and the knee clamped in position, a square (vertical leg about 12 inches long) is clamped to the table. A dial gauge is fixed to the spindle with the dial-gauge plunger touching the vertical leg of the square at the top end in the horizontal plane. The knee is then unclamped, raised by 300 millimetres (12 inches) and reclamped, readings being taken in the top and bottom position. Two sets of readings are necessary:

- (a) to test the perpendicularity between the table surface and the front of the columnways (Fig. 71A)

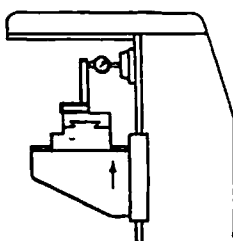

Fig. 71A

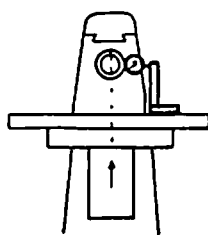

Fig. 71B

Fig. 71A and 71B. Perpendicularity between Table Surface and Columnway for the Knee

- (b) to test the perpendicularity between the table surface and the side of the columnways (Fig. 71B).

As far as possible no differences should be found between the readings taken with the knee in its clamped or unclamped position. It is recommended that at least five readings be taken. Care should also be taken to check the square before this test is carried out.

(C) IN THE CASE OF CYLINDRICAL GRINDING MACHINES, parallelism has to be checked between:

1. The table slideways and the slideways or locating faces for headstock and tailstock. (Test Chart 21, Fig. 2).
2. The spindle axis (internal taper) and the direction of the table traverse in
  - (a) the vertical plane (Test Chart 21, Fig. 6a);
  - (b) the horizontal plane (Test Chart 21, Fig. 6b).
3. The spindle in the swivelling headstock and the direction of the in-feed movement of the grinding head in the vertical plane, measured with the headstock in the 90° position (Test Chart 21, Fig. 7).
4. The tailstock sleeve (internal taper) and the direction of the table movement
  - (a) in the vertical plane (Test Chart 21, Fig. 9a);
  - (b) in the horizontal plane (Test Chart 21, Fig. 9b).
5. The grinding wheel spindle and the direction of the table movement
  - (a) in the vertical plane (Test Chart 21, Fig. 12a);
  - (b) in the horizontal plane (Test Chart 21, Fig. 12b).
6. The internal grinding spindle and the direction of the table movement (see item 5)
  - (a) in the vertical plane;
  - (b) in the horizontal plane.

*Testing procedure:* 1. This has been covered on page 29 and Fig. 38.

2. (Fig. 72). The table is put in zero position for cylindrical grinding and a 300 millimetres (12 inches) long test mandrel is fixed in the workpiece-spindle taper. The dial gauge is fixed to the grinding-wheel slide, with the dial-gauge plunger touching the test mandrel (in the case of machines with rotating workpiece-spindle this has to be rotated into its mean position). The table is traversed longitudinally by an amount equal to the length of the test mandrel and the readings are taken.

- (a) The free end of the mandrel must rise,
- (b) The free end of the mandrel must be inclined towards the grinding wheel.

3. (Fig. 73). This applies only to universal grinding machines. The test is similar to test 2 except for the fact that the dial gauge is clamped to the grinding wheel slide

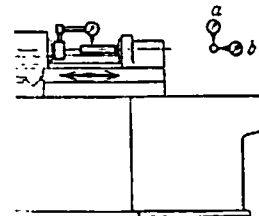

Fig. 72. Parallelism between the Spindle Axis and the Direction of the Table Traverse

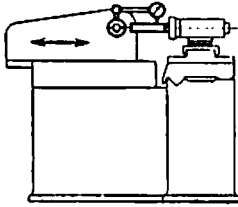

Fig. 73. Parallelism between the Spindle Axis and the Direction of the Infeed Movement (Universal Grinding Machines)

which is moved by an amount equal to the total in-feed movement. For the 90° setting, it is sufficient to rely on the graduation of the swivelling-head scale, as the measurement is only taken in the vertical plane and excessive accuracy in the angular position is not essential. The mandrel must rise towards its free end. The inspector also checks whether the spindle is level with the mandrel in the zero and 90° position.

4. (Fig. 74). With the table in the zero position for cylindrical grinding, a 300 millimetres (12 inches) long test mandrel is located in the taper of the fully withdrawn and clamped tailstock sleeve. A dial gauge is fixed to the

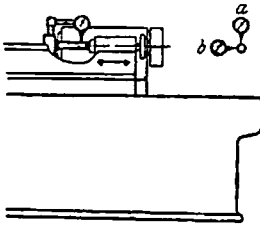

Fig. 74. Parallelism between Tailstock Sleeve and Direction of Table Traverse

grinding-wheel slide, with the dial-gauge plunger touching the test mandrel. The table is traversed longitudinally by an amount equal to the length of the test mandrel and readings are taken:

- (a) the free end of the mandrel must rise,
- (b) the free end of the mandrel must be inclined towards the grinding wheel.

5. (Fig. 75). A 100 millimetres (4 inches) long test mandrel is fixed to the grinding-wheel spindle (the locating and clamping depends upon the design of the spindle nose), and a dial gauge is fixed to the table with the dial-gauge plunger touching the test mandrel which has been rotated into its mean position. The table is traversed longitudinally by an amount equal to the length of the test mandrel and readings are taken:

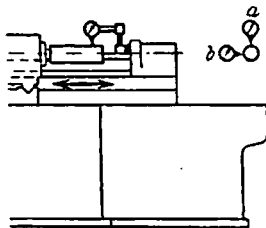

Fig. 75. Testing Parallelism between Grinding-wheel Spindle and Table Movement

- (a) the free end of the mandrel must rise,
- (b) the free end of the mandrel must be inclined towards the table.

6. (Fig. 76). A 100 millimetres (4 inches) long test mandrel is fixed in the internal-grinding spindle support (method of concentric location and fixing depending on the particular design). A dial gauge is fixed to the table with the dial-gauge plunger touching the test mandrel

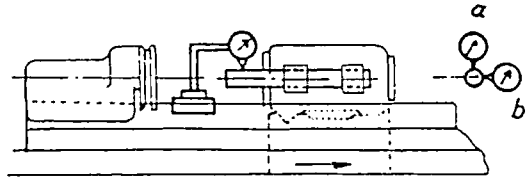

Fig. 76. Parallelism between the Internal Grinding Spindle and the Table Movement

which has to be rotated into its mean position. The table is traversed longitudinally by an amount equal to the length of the test mandrel and readings are taken.

The height alignment of two corresponding axes is tested in a similar manner as described previously for the case of the lathe (see Fig. 60) and the milling machine (see Figs. 1, 52 and 53). In the case of the grinding machine the following height alignments are checked:

1. Workpiece spindle and tailstock spindle centres (Test Chart 21, Fig. 10).
2. Workpiece and external grinding wheel spindles (Test Chart 21, Fig. 13).
3. Workpiece and internal grinding spindles (as item 2).
4. Rise and fall of grinding wheel spindle during its in-feed movement (Test Chart 21, Fig. 14).

*Testing procedure:* 1. (Fig. 77). A 300 to 800 millimetres (12 to 32 inches) long hollow test mandrel with accurately centred faces is held between centres. A dial gauge is fixed to the grinding-wheel slide, with the dial-

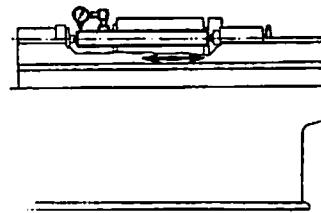

Fig. 77

gauge plunger touching the test mandrel (for measurement in the vertical plane). The table is moved longitudinally and readings are taken. The tailstock centre must be higher than the headstock centre. Measurement in the horizontal plane is not necessary, as alignment in this plane is adjustable.

2. (Figs. 78 and 79). Two test mandrels ( $D_1$  and  $D_2$ ), approximately 100 millimetres (4 inches) long, and of exactly equal diameter are used. Test mandrel  $D_2$  has a standard taper shank and is located in the workpiece spindle taper; test mandrel  $D_1$  is fixed to the grinding-wheel spindle, the type of location and fixing depending on the design of the spindle nose.



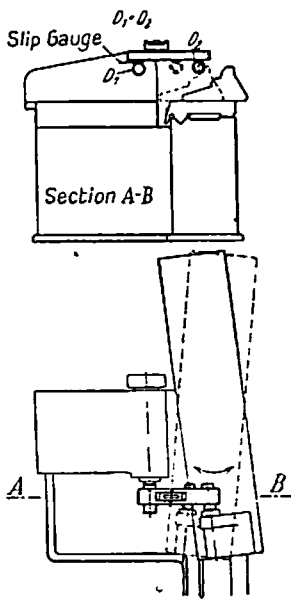

Fig. 78

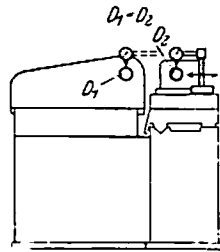

Fig. 79

If the grinding-wheel spindle has a cylindrical portion, this may be used instead of test mandrel  $D_1$ . In this case the difference between the diameter of test mandrel  $D_2$  and that of the spindle cylinder must be compensated by block gauges.

The grinding-wheel slide is moved into the middle position of its traverse and the test mandrels  $D_1$  and  $D_2$  are rotated into their mean positions.

(a) (Fig. 78). A straight-edge is rested on both test mandrels and a spirit level is placed on the straight edge. Spirit level readings are taken; or

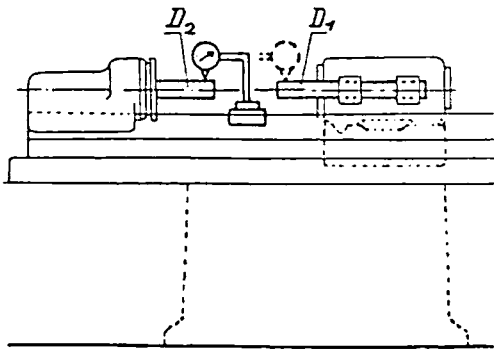

Fig. 80

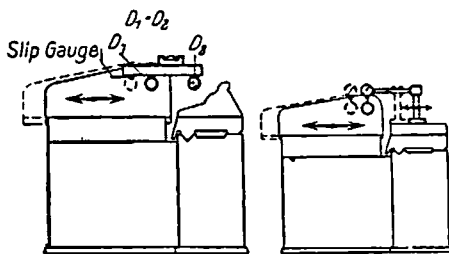

Fig. 81A

Fig. 81B

(b) (Fig. 79). A dial gauge is fixed to the machine table with the dial-gauge plunger touching the tops of test mandrels  $D_1$  and  $D_2$ , and readings are taken.

The table is swivelled in both directions and readings repeated with the table in extreme position.

3. (Fig. 80) (see also item 2). This uses two test mandrels  $D_1$  and  $D_2$  as before, but the test mandrel  $D_1$  is fastened in the internal grinding spindle support. The test mandrels are rotated into their mean positions. The dial gauge is fixed to the machine table. The dial-gauge plunger touches the tops of the free ends of the test mandrels and readings are taken.

4. (Figs. 81A and 81B). The grinding-wheel slide is located in the extreme backward position. A 100 millimetres (4 inches) long test mandrel is fixed to the grinding-wheel spindle as before, and rotated into its mean position.

(a) (Fig. 81A). Here, a straight-edge and spirit level are placed on the two test mandrels  $D_1$  and  $D_2$ ; or

(b) (Fig. 81B). The dial gauge is fixed to the machine table with the dial-gauge plunger touching the top of the test mandrel and readings are taken. The grinding-wheel slide is fed in into its extreme forward position and readings are taken.

The final test concerns the perpendicularity between the in-feed movement of the grinding-wheel slide and the workpiece axis in the zero position of the table, when the workpiece axis must be parallel to the slideways of the bed (Test Chart 21, Fig. 15).

*Testing Procedure:* (Fig. 82). The machine table is set in the zero position; and the grinding-wheel slide in the extreme backward position. A 500 millimetres (20 inches) long test mandrel with accurately centred faces is mounted between centres. If possible, the test mandrel should have a 300 millimetres (12 inches) long flat face about 20 millimetres ( $\frac{3}{4}$  inch) wide, against which a square can be held. The dial gauge is fixed to the grinding-wheel slide, with the dial-gauge plunger touching the free leg of the square. The grinding-wheel slide is moved forward and readings are taken.

It is also possible to fix the dial gauge to the grinding-wheel spindle and take a trammel reading against the free leg of the square.

(D) IN THE CASE OF RADIAL DRILLING MACHINES the following have to be checked:

1. Parallelism between the drilling-head slideways on the radial arm and the base plate (Test Chart 34, Fig. 3).
2. Perpendicularity between the spindle axis and the base plate (Test Chart 34, Fig. 6):

- (a) Longitudinally.
- (b) Transversely.

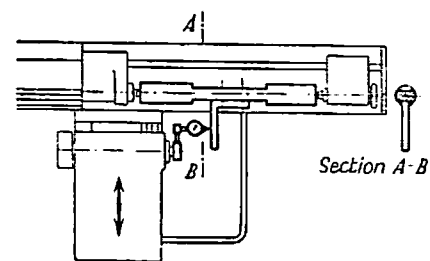

Fig. 82

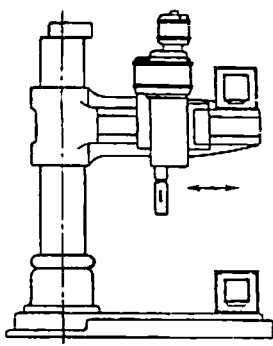

Fig. 83.  
Checking for Parallelism

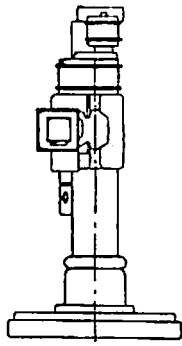
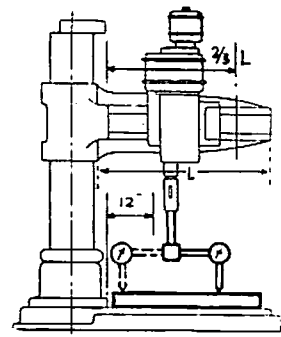

Fig. 84.  
Checking the Arm

Fig. 86.  
Perpendicularity of Spindle



3. Perpendicularity between the feed movement of the spindle and the base plate (Test Chart 34, Figs. 7 and 8).

1. The radial arm must remain parallel to the base plate whatever the position into which it is rotated round the column. A spirit level (scale value 0.04 millimetre/1,000 millimetres; or 0.0005 inch/foot) is placed at the extreme end of the radial arm (Fig. 83). The drilling head is moved along the radial arm and spirit level readings are taken. As the permissible error is 0.2 millimetre/1,000 millimetres (0.0025 inch/foot) the maximum permissible movement of the air bubble is five divisions. Moreover, the radial arm must always be inclined downwards towards its outer end, because the drill thrust will tend to raise it. In most designs the drilling head is guided on an offset vertical surface of the radial arm. The flatness of this surface is checked in a manner similar to that used for testing the horizontal surface of a lathe bed. A frame spirit level is held against this surface at intervals of 200 millimetres (8 inches) (Fig. 84). In the case of radial arms with a central drilling-head support (symmetrical design), the procedure has to be modified accordingly. In an alternative method of checking the parallelism between the drilling-head slideways and the base plate, a dial gauge and straight-edge are used as shown in Fig. 85A. The radial arm is raised to the middle position of its vertical movement. A 1,000 millimetres (40 inches) long straight-edge is placed longitudinally on the base plate

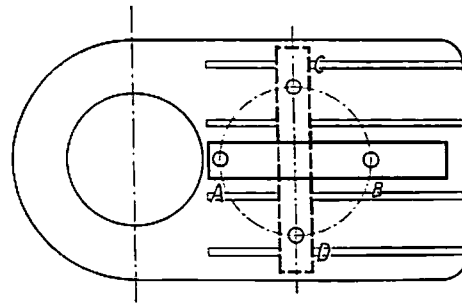

Fig. 87

after the latter has been levelled. The dial gauge is fixed to the spindle, the dial-gauge plunger touching the straight-edge. The drilling head is traversed over the whole length of the radial arm. The reading of the dial gauge must not vary by more than 0.2 millimetre/1,000 millimetres (0.0025 inch/foot). (N.B.—It is not sufficient to check isolated portions of the traverse and to calculate the error *pro rata*).

In a third method, the dial gauge is fixed to the spindle as mentioned before and readings are taken in three positions (a, b, c) of the drilling head on the radial arm (Fig. 85B). The dial-gauge plunger touches the surface of the base plate. The radial arm is rotated round the axis of the column and readings are taken, the maximum permissible error being 0.2 millimetre/1,000 millimetres (0.0025 inch/foot). This method is particularly suitable in the case of T-shaped or cruciform plates.

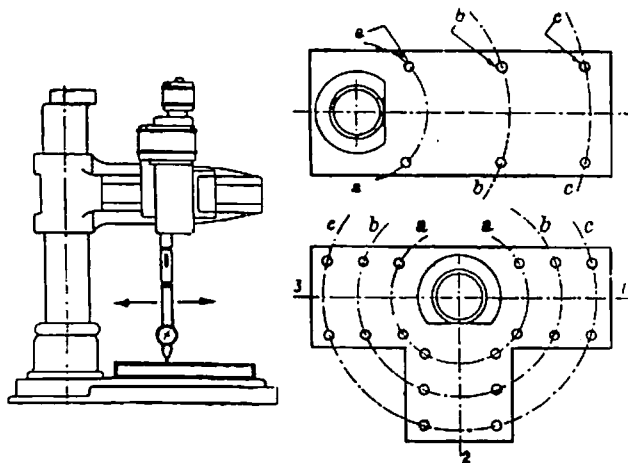

Fig. 85A. Parallelism of  
Drilling-head Slideways  
and Base

Fig. 85B. Alternative Method  
of Checking Parallelism

2. *Testing procedure:* (Fig. 86). The radial arm is raised to one-third of its vertical movement, and the spindle axis is positioned at approximately 300 millimetres (12 inches) distance from the column flange. A trammel arm at least 250 millimetres (10 inches) long and carrying the dial gauge is fixed to the spindle. The dial-gauge plunger touches the surface of the base plate or the surface of a straight-edge placed on it. The spindle is rotated by 360° and readings are taken.

The drilling head is moved outward by an amount equal to two-thirds of the length  $L$  of the radial arm and readings are again taken as above. The radial arm is raised to two-thirds of its total vertical movement and readings are again taken in both positions of the drilling head on the radial arm as before.

If the dial-gauge plunger is not touching the surface of the base plate but that of a straight-edge (which should be about 1,000 millimetres, 40 inches, long) (Fig. 87) trammel

EQUIVALENT TABLES

1. For Converting Mm. Tolerances into Inch Tolerances

Mm.	Inch	Mm.	Inch
0-003	0-00012	0-06	0-0024
0-005	0-0002	0-07	0-0028
0-01	0-0004	0-075	0-0030
0-015	0-0006	0-08	0-0032
0-02	0-0008	0-10	0-0040
0-025	0-0010	0-13	0-0052
0-03	0-0012	0-15	0-0060
0-032	0-00126	0-20	0-0080
0-038	0-0015	0-25	0-0100
0-04	0-0016	0-3	0-0120
0-045	0-0018	1-0	0-0400
0-05	0-0020	1-5	0-0600
0-052	0-00205	2-5	0-1000

2. Metric Reference Lengths into Inch Reference Lengths

Mm.	Inches	Mm.	Inches
20	$\frac{1}{2}$	150	6
25	1	300	12
35	$1\frac{1}{4}$	500	20
50	2	800	32
75	3	1,000	40
100	4		

3. Metric Tolerances Referred to Various Lengths into Inch Tolerances Referred to 1 Foot and 3 Feet

Mm.	Inch per Foot	Inch per 3 Feet
0-01 per 1,000 mm.	0-00012	0-00036
0-015 " 1,000 "	0-00018	0-00054
0-02 " 1,000 "	0-00024	0-00072
0-03 " 1,000 "	0-00036	0-00108
0-04 " 1,000 "	0-00048	0-00144
0-05 " 1,000 "	0-00060	0-00180
0-06 " 1,000 "	0-00072	0-00216
0-10 " 1,000 "	0-00120	0-00360
0-20 " 1,000 "	0-00240	0-00720
0-30 " 1,000 "	0-00360	0-01080
1 " 1,000 "	0-01200	0-03600
1-5 " 1,000 "	0-01800	0-05400
2-5 " 1,000 "	0-03000	0-09000
0-02 " 800 "	0-00030	0-00090
0-04 " 800 "	0-00060	0-00180
0-02 " 500 "	0-00048	0-00144
0-03 " 500 "	0-00072	0-00216
0-01 " 300 "	0-00040	0-00120
0-015 " 300 "	0-00060	0-00180
0-02 " 300 "	0-00080	0-00240
0-03 " 300 "	0-00120	0-00360
0-04 " 300 "	0-00160	0-00480
0-05 " 300 "	0-00200	0-00600
0-06 " 300 "	0-00240	0-00720
0-07 " 300 "	0-00280	0-00840
0-08 " 300 "	0-00320	0-00960
0-10 " 300 "	0-00400	0-01200
0-13 " 300 "	0-00520	0-01560
0-03 " 150 "	0-00240	0-00720
0-15 " 150 "	0-01200	0-03600
0-01 " 100 "	0-00120	0-00360
0-015 " 100 "	0-00180	0-00540
0-02 " 100 "	0-00240	0-00720
0-03 " 100 "	0-00360	0-01080
0-04 " 100 "	0-00480	0-01440
0-07 " 100 "	0-00840	0-02520
0-10 " 100 "	0-01200	0-03600
0-075 " 75 "	0-01200	0-03600
0-01 " 50 "	0-00240	0-00720
0-015 " 50 "	0-00360	0-01080
0-05 " 50 "	0-01200	0-03600
0-04 " 35 "	0-01370	0-04110
0-03 " 25 "	0-01470	0-04320
0-025 " 20 "	0-01500	0-04500

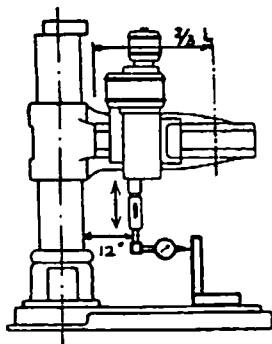

Fig. 88

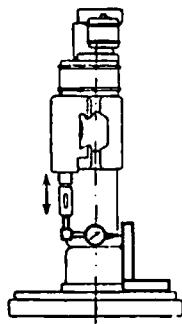

Fig. 89

readings can only be taken at the 0° and 180° positions (A and B). The 90° and 270° measurements, (C and D) must be taken after the straight-edge has been turned 90°. This method is more cumbersome and waviness or irregularities of the base plate surface are covered up.

3. (Figs. 88, 89). The radial arm is raised to one-half of its vertical movement and the spindle axis located at approximately 300 millimetres (12 inches) from the column flange. The square is placed on the base plate first in the longitudinal and then in the transverse direction. The dial gauge is fixed to the spindle, the dial-gauge plunger touching the free leg of the square. Spindle and dial gauge are moved up and down (hand feed) and readings are taken. The drilling head is moved to two-thirds of the radial arm length and measurements are repeated in both planes.

### B. TESTING THE ACCURACY OF WORKPIECES PRODUCED DURING A FINISHING OPERATION

Reference is made to pages 5-7.

It is not yet possible to establish rigid specifications for this purpose similar to those for testing the accuracy with which the machine has been manufactured. The working accuracy of each machine is specified at the end of the Test Charts. It will often be left to the manufacturer to choose workpieces and tools for testing, and to ensure that

### Performance Tests

Test to be applied	Dimensions of piece	Gauge and methods	Tolerances
1. <i>Lathe</i>			
(a) Round turning (chucking)	Diameter = $\frac{1}{2}$ centre height .. Length = centre height	Made on 2 bands of cylinder, 1 inch distant from each end and 1 inch wide. Standard micrometers 0.0025 mm. (0.0001-inch)	0.01 mm. (0.0004-inch)
(b) Parallel turning (chucking)	—	—	0.03 mm. per 300 mm. (0.0012-in. per foot)
(c) Parallel turning between centres	Diameter = $\frac{1}{2}$ length. Length from $\frac{1}{2}$ to 1 distance between centres	Standard tools	0.02 mm. (0.0008-inch) in any length
(d) Facing (concave only) ..	Diameter = centre height. Length about centre height	Standard tools	0.02 mm. per 300 mm. diameter (0.0008-in. per foot)
(e) Screwing .. .. .	Diameter = 25 mm. (1 inch). Length of thread, 50 mm. (2 inches) Length of thread, 300 mm. (12 inches)	Standard tools  —	$\pm 0.02$ mm. (0.0008-inch) total pitch error  $\pm 0.05$ mm. (0.002-inch)
2. <i>Milling Machine</i>			
(a) Slab milling (finishing cut) the top and bottom faces of a block to a uniform thickness	Cast-iron (or mild steel) block of at least 75 x 75 mm. (3 inches x 3 inches) x 400 mm. (16 inches) long. For longer pieces 100 x 100 mm. (4 inches x 4 inches) x 750 mm. (30 inches) long (Fig. 90A)	Take, at first, one finishing cut of approximately 0.1 mm. (0.004-inch) depth over each surface. Micrometer or dial gauge test. The clamping of the block should permit the test to be completed in one setting. The eccentricity of the milling cutter when in position should not be more than 0.05 mm. (0.002-inch). The cutter should be 90 mm. (3 $\frac{1}{2}$ inches) resp., 115 mm. (4 $\frac{1}{2}$ inches) wide	0.025 mm. per 300 mm. (0.001-in. per foot)
(b) Facing with a cutter head or end mill mounted on a short arbor in the spindle. Traversing longitudinally. Milling parallel strips, the higher ones overlapping the lower ones	Cast-iron (or mild steel) block, 150 mm. x 150 mm. (6 inches x 6 inches) shaped for clamping (Fig. 90B)	Take 3 finishing cuts 50 mm. (2 inches) wide x 0.10 mm. (0.004-inch) deep which overlap by 10 mm. ( $\frac{3}{8}$ -inch). Vertical movement of the knee by hand. Test with a straight-edge and clock	0.015 mm. per 300 mm. (0.0006-in. per foot) longitudinally, and 0.005 mm. (0.0002-inch) maximum overlap variation in clock reading

Test to be applied	Dimensions of piece	Gauge and methods	Tolerances
3. <i>Grinding Machine</i> (a) Machine grinds round (1) between centres (2) chucking	Diameter 80 mm. ( $3\frac{1}{8}$ inches) 80 to 200 mm. ( $3\frac{1}{8}$ to 8 inches) long;  Over 200 mm. (8 inches) long	Piece either between dead centres or in chuck. For long pieces, 3 bands 50 mm. (2 inches) wide at both ends and at centre. Grinding wheel well dressed, maximum permissible diameter. Width 0.1 x diameter of wheel. Speed 4,000 to 5,000 feet per min. Feed $\frac{1}{4}$ width of wheel. Standard tools	(1) 0.003 mm. (0.0001-inch) } when less than 200 mm long (2) 0.005 mm. (0.0002-inch) } (1) 0.01 mm. (0.0004-inch) — when over 200 mm. long
(b) Machine grinds parallel between centres	Shafts 1,000 mm. (40 inches) long x 80 mm. ( $3\frac{1}{8}$ inches) diameter Shafts 500 mm. (20 inches) long, 50 mm. (2 inches) diameter Shafts 250 mm. (10 inches) long, 38 mm. (1.5 inches) diameter	Piece turns round between dead centres without steadies. Standard tools	0.015 mm. (0.0006-inch)  0.008 mm. (0.0003-inch)  0.005 mm. (0.0002-inch)
(c) Fine infeed test (Fig. 90c)	—	Test against grinding wheel periphery or diameter of wheel spindle. Dial-gauge reading repeated six times. Dial gauge rigidly clamped to table	0.002 mm. (0.0001-inch)
(d) Quick approach (infeed) to the work repeats accurately to grinding position (Fig. 90c)	—	Ditto	0.003 mm. (0.00012-inch)

Fig. 90. Performance Tests

Various Machining Operations, Recommended Dimensions of Specimens, Gauges and Methods, Permissible Tolerances.

the machine is free from vibrations and other faults. If necessary, it is, of course, possible to agree beforehand with the customer on type and form of the test piece. An attempt has been made to establish specifications for performance tests of lathes, milling machines and grinding machines (Fig. 90).

No such specifications have been attempted for the case of drilling machines (Test Charts 31 to 34), presses and shearing machines (Test Charts 51 to 53). When rough holes are drilled it is only important for these to be perpendicular to the base and parallel to each other. In this case, it is sufficient to check the deflection under the

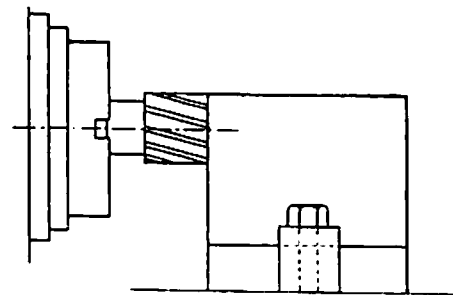

Fig. 90b. Performance Test on Milling Machine—Face Milling

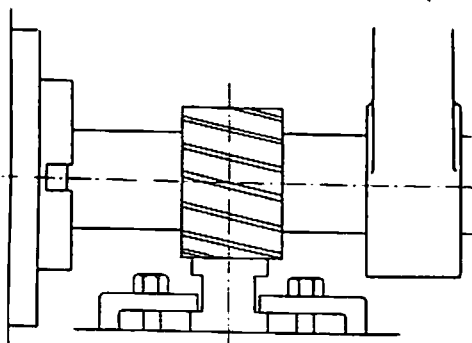

Fig. 90a. Performance Test on Milling Machine—Slab Milling

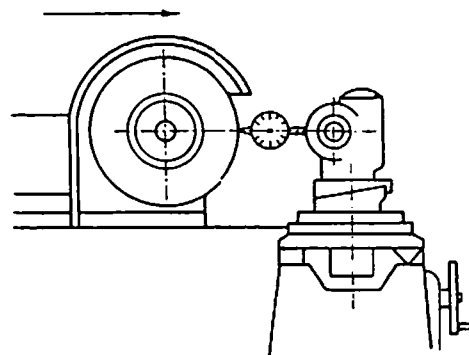

Fig. 90c. Fine In-feed Test

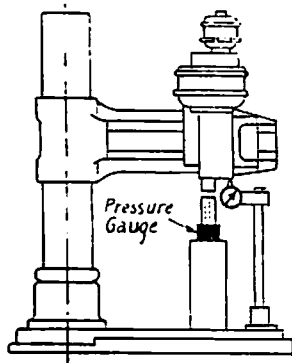

Fig. 91. Testing Vertical Thrust on Drilling Machine

largest possible axial force acting on the drill spindle (see page 22). The testing procedure is as follows (Fig. 91):

The radial arm is raised to half its vertical movement and the drilling head placed in its extreme outward position. A dynamometer (or a load cell and pressure gauge) is positioned under the spindle. A dial gauge is fixed to a column on the base plate, the dial-gauge plunger touching the bottom of the drilling head. The spindle is fed forward (hand feed) until the permissible axial thrust is indicated by the dynamometer, when the reading of the dial gauge is taken.

In the case of power presses the accuracy of the slideways must be maintained when the machine is subjected to the maximum permissible force. This is essential in order to prevent the punch being damaged in the die.

### Surface Quality

The author investigated the problem of surface finish during the years 1939 to 1949.\* His attempt to specify the surface quality which ought to be achieved with

various machining operations is shown in the Table (Fig. 92).

### C. POWER REQUIREMENTS, SPEEDS AND FEEDS

Every machine tool must be so designed that its parts will not be deformed beyond permissible limits when subjected to the maximum working load. If the supplier wishes to limit the permissible load or if he does not intend the machine to be used in a certain specific manner this should be definitely stated either in writing or in his prospectus. For instance, many lathes are not designed for taking the largest possible cuts when the tool is acting on the maximum diameter. On the other hand, today's ever-increasing speeds will be accompanied by smaller cutting forces if the power of the machine remains constant.

The relation between speed, cutting force and power consumption is  $P = \frac{F \times v}{33,000 \times \eta}$  h.p.; where

- F = cutting force in pounds,
- v = cutting speed in feet per minute,
- $\eta$  = efficiency factor.

If the mean efficiency for the whole machine is assumed to be  $\eta = 0.67$  then the formula becomes  $P = \frac{F \times v}{22,000}$  h.p.

The power consumption of a machine can be determined by taking voltmeter and ammeter readings.

The performance test of a machine tool should also check the speeds and feeds. Most modern machine tools carry plates which show the numerical values of the various speeds and feeds available, and the actual values can be checked against the nominal ones by means of rev.-counters or similar instruments. Standardisation of speeds and feeds based on the internationally accepted system of "preferred numbers" should facilitate the work of designers, manufacturers and users of machine tools, and should form the basis of suitable acceptance tests.

\* G. Schlesinger, "Report on Surface Finish", The Institution of Production Engineers, 1941; "Messung der Oberflächengüte", Springer-Verlag, 1951.

Machining a plane surface by	have/ $\mu$ in.			Remarks
	Commercial Finish	Fine Finish	Superfine Finish	
Milling .. ..	32.1 to 63	16.1 to 32	8.1 to 16	Face milling gives finer surfaces than slab milling
Planing .. ..	16.1 to 63	8.1 to 16	4.1 to 8	The planer is a very robust machine, the tool action is uniform
Surface Grinding	8.1 to 16	4.1 to 8	2.1 to 4	All depends on the machine and the correct selection of the grinding wheel
Scraping .. ..	8.1 to 16	4.1 to 8	2.1 to 4	All depends on the skill of the operator

Fig. 92. Surface finish tests for Plain Surfaces

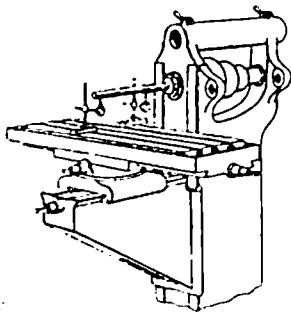

Fig. 1

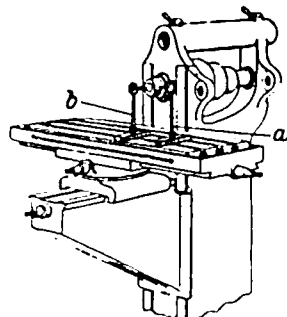

Fig. 2

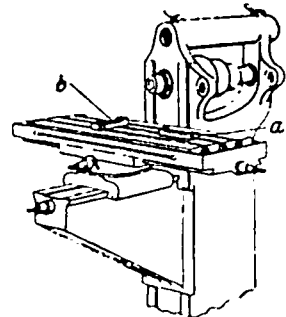

Fig. 3

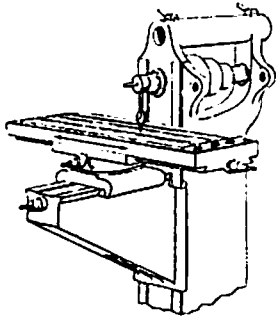

Fig. 4

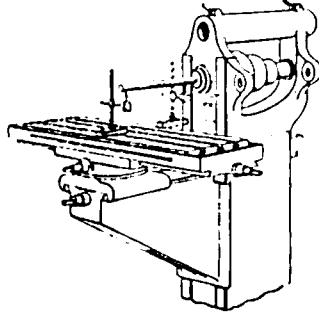

Fig. 5

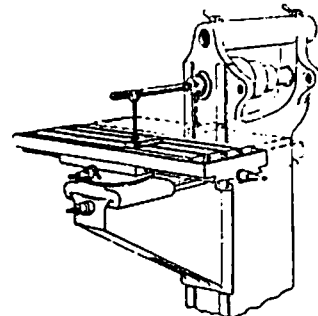

Fig. 6

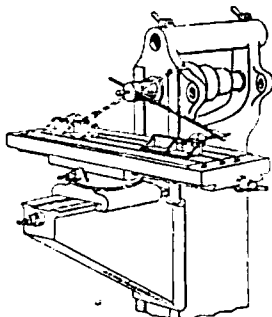

Fig. 7

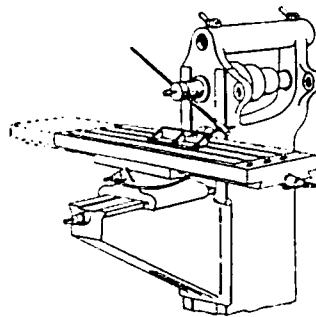

Fig. 8

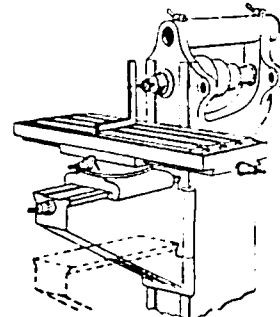

Fig. 9

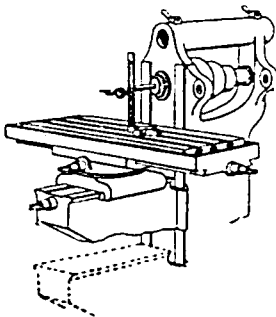

Fig. 10

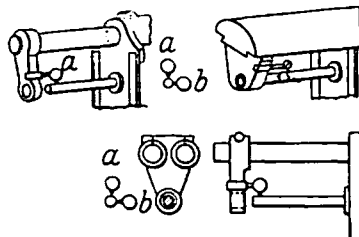

Fig. 11

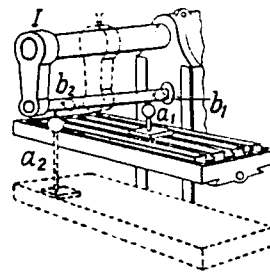

Fig. 12

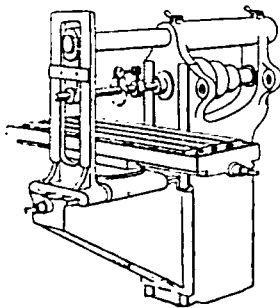

Fig. 13

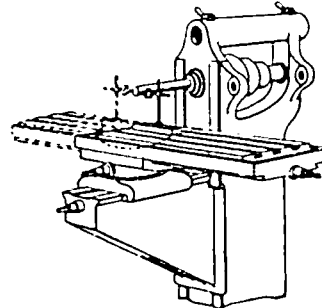

Fig. 14

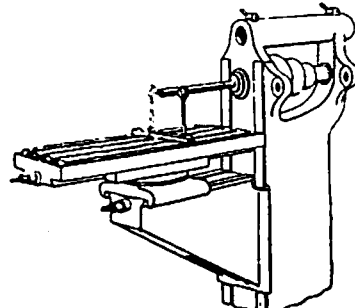
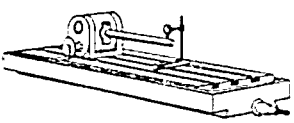
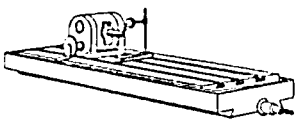
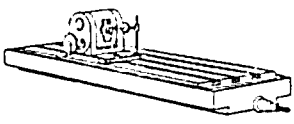
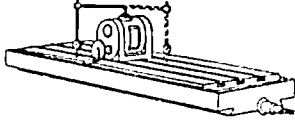
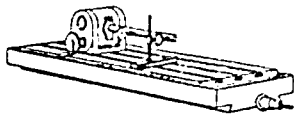
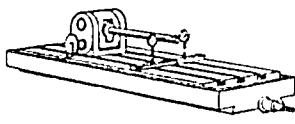
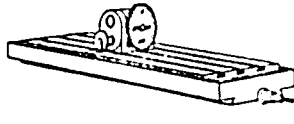
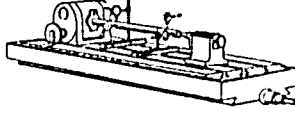

Fig. 15

Test Chart for Knee-type Horizontal Milling Machines and Universal Milling Machines		No. 1 Chart 1
Test to be Applied	Fig. No.	Permissible Error
Levelling of work table: Work table flat or level in longitudinal direction (table placed in central position)	3a	mm. ±0.04 per 1,000 mm.
Ditto, in transverse direction	3b	±0.04 per 1,000 mm.
<b>A. Horizontal milling machine</b>		
Cutter spindle:		
Internal taper runs out of truth (1) Nearest to the spindle nose (2) At a distance of 300 mm. (12 in.)	1	0.01 0.02
External taper or external cylindrical surface runs out of truth Fastening of mandrel corresponds to standards.	2a	0.01
Cutter spindle for axial slip in machines with front bearings up to 50 mm. (2 in.) dia.	2b	0.01
Front bearing over 50 mm. (2 in.) dia.		0.02
Rise and fall of table in its longitudinal motion	4	0.02 per 500 mm.
Over 500 mm. addition of 0.01 per 500 mm.		
Work table parallel with cutter spindle (table rising towards front side)	1	0 to 0.02 per 300 mm.
Transverse movement of table parallel with cutter spindle in vertical plane	5	0.02 per 300 mm.
Ditto, in horizontal plane	6	0.02 per 300 mm.
Centre T-slot square with cutter spindle* (turn round method)	7	0.02 per 300 mm.
* May be replaced by using a square on the table		

Test Chart for Knee-type Horizontal Milling Machines and Universal Milling Machines		No. 1 Chart 2
Test to be Applied	Fig. No.	Permissible Error
Centre T-slot parallel with table movement	8	mm. 0.02 per 300 mm.
Total error up to 600 mm. (24 in.)		0.02
1,000 mm. (40 in.)		0.03
above 1,000 mm. (40 in.)		0.04
Width of T-slots:		
From 10 to 12 mm. (3/8 to 1/2 in.)		0 to +0.015
From 14 to 18 mm. (1/2 to 3/4 in.)		0 to +0.02
Over 18 mm. (3/4 in.)		0 to +0.025
Column ways for knee square with work table, inclination towards front or rear side. Tested with clamped and loose knee.	9	0.02 per 300 mm.
Ditto, inclination to sides	10	0.02 per 300 mm.
Over arm (one bar, twin bars, box section): Tightened over-arm parallel with cutter spindle in vertical plane	11a	0.02 per 300 mm.
Ditto in horizontal plane measured near nose and in 300 mm. distance	11b	0.02 per 300 mm.
Bore of arm bracket aligned with cutter spindle:	12	
I. Table in top position: (1) a <sub>1</sub> a <sub>2</sub> in vertical plane (2) b <sub>1</sub> b <sub>2</sub> in horizontal plane		0.02/300 mm. 0.02/300 mm.
II. Table in bottom position: (1) a <sub>1</sub> a <sub>2</sub> in vertical plane (2) b <sub>1</sub> b <sub>2</sub> in horizontal plane		0.02/300 0.02/300
a. Bracket in outer position } for I b. Bracket in middle position } and II Arm and bracket clamped		
Bore of arm bracket aligned with cutter spindle, with tightened outer arm support, measured in the top and bottom positions of knee	13	0.02 mm.
<b>B. Universal milling machine</b>		
Swivel carriage:		
Axis of swivel carriage off-set with respect to cutter spindle	14	0.05
Centre T-slot of work table off-set with respect to cutter spindle	15	0.05

Testing Dividing Heads		1a
		
Fig. 1	Fig. 2	
		
Fig. 3	Fig. 4	
		
Fig. 5	Fig. 6	
		
Fig. 7	Fig. 8	

Test Chart for Dividing Heads Operated by Hand		No. 1A Chart 1
Test to be Applied	Fig. No.	Permissible Error
Taper of dividing head spindle runs true: (1) Near nose (2) At a distance of 300 mm. (12 in.)	1	mm. 0.01 0.02
Centre point for true running	2	0.01
Dividing head spindle for axial slip	3	0.01
Dividing head spindle square with clamping surface	4	0.02 per 300 mm.
Dividing head spindle parallel with centre T-slot	5	0.02 per 300 mm.
Dividing head spindle laterally off-set with respect to centre T-slot	6	0.02
Maximum permissible dividing error: (1) For intermediate divisions (2) For the total	7	±45 sec. ±1 min.
Working axis (mandrel between centres) parallel with clamping surface (degree of incline between dividing head and tailstock)	8	0.02 per 300 mm.
Working axis (mandrel between centres) parallel with centre T-slot (lateral off-set between dividing head and tailstock)	8	0.02 per 300 mm.



## Testing Surface Milling Machines

2

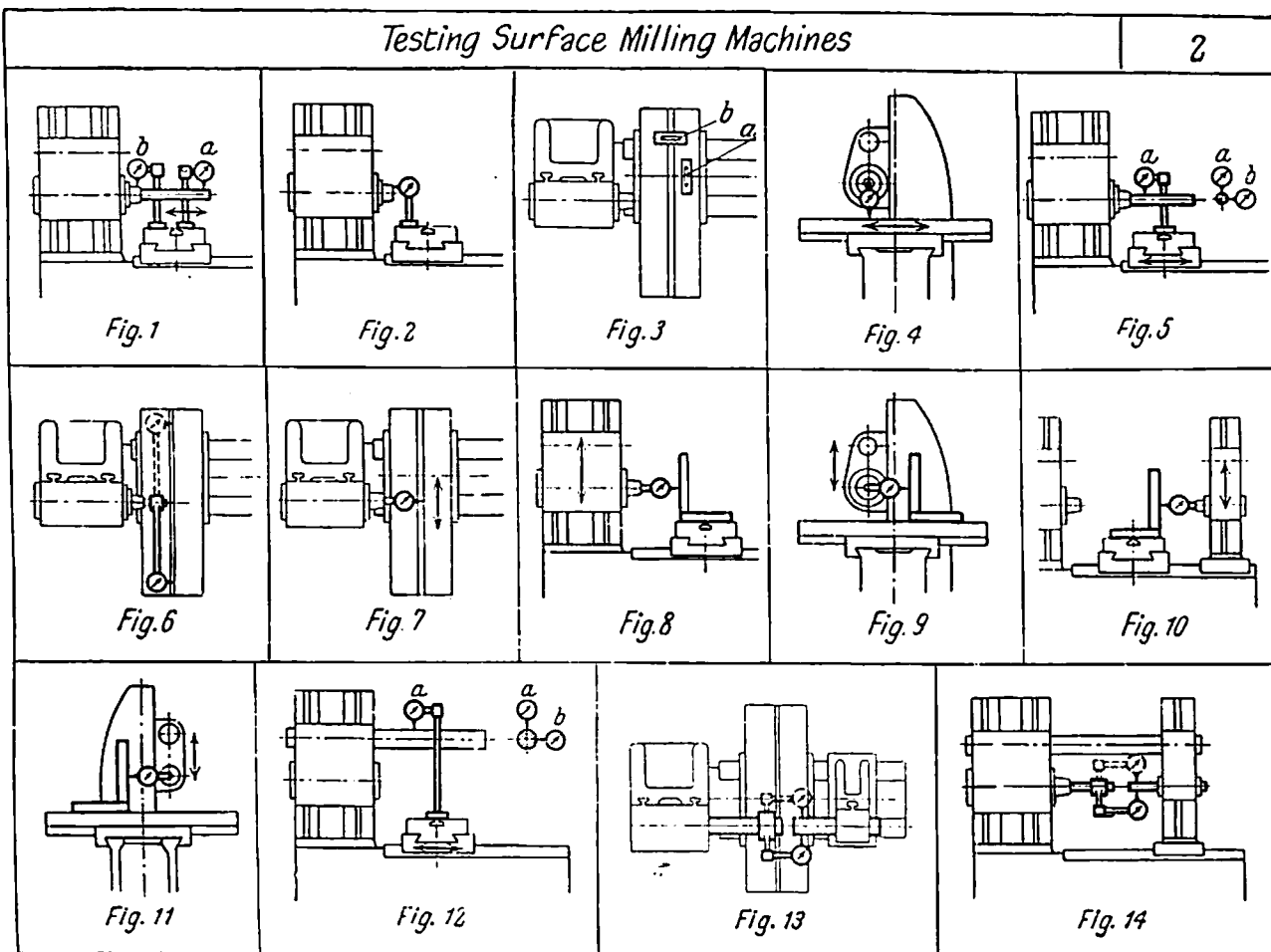

Test Chart for Surface Milling Machines		No. 2 Chart 1
Test to be Applied	Fig. No.	Permissible Error
<b>Levelling of work table:</b>		
Work table flat or level in longitudinal direction	3a	mm. ±0.04 per 1,000 mm.
Ditto, in transverse direction	3b	±0.04 per 1,000 mm.
<b>Cutter spindle:</b>		
Internal taper of cutter spindle runs true:	1a	0.01 0.02
(1) Nearest the spindle nose		
(2) At a distance of 300 mm. (12 in.)		
External taper runs out of truth	1b	0.01
Cutter spindle for axial slip for machines with up to 50 mm. (2 in.) dia. of front bearing at 2 opposite positions	2	0.01 0.02
Over 50 mm. (2 in.) dia. of front bearing		
Rise and fall of table in its lengthwise movement	4	0.02 per 500 mm.
Over 500 mm., addition of 0.01 per 500 mm.		
Work table parallel with cutter spindle	1a	0.02 per 300 mm.
Transverse movement of table parallel with cutter spindle in vertical plane	5a	0.02 per 300 mm.
Ditto, in horizontal plane	5b	0.02 per 300 mm.
Centre T-slot square with cutter spindle	6	0.02 per 300 mm.
Total error: Up to 600 mm., 0.02 mm.; up to 1,000 mm., 0.03 mm.; over 1,000 mm., 0.04 mm.		
Centre T-slot parallel with table movement	7	0.02 per 300 mm.

Test Chart for Surface Milling Machines		No. 2 Chart 2
Test to be Applied	Fig. No.	Permissible Error
<b>Width of T-slots:</b>		
From 10 to 12 mm. ( $\frac{3}{8}$ to $\frac{1}{2}$ in.)	..	mm. 0 to +0.015
From 14 to 18 mm. ( $\frac{9}{16}$ to $\frac{3}{4}$ in.)	..	0 to +0.02
Over 18 mm. ( $\frac{3}{4}$ in.)	..	0 to +0.025
Work table square with vertical adjustment of headstock in plane of cutter spindle	8	0.02 per 300 mm.
Ditto, in plane perpendicular to that of cutter spindle	9	0.02 per 300 mm.
<b>Over-arm and bracket:</b>		
Vertical adjustment of over-arm support square with work table in plane of cutter spindle. Support always tightened	10	0.02 per 300 mm.
Ditto, in plane perpendicular to that of cutter spindle	11	0.02 per 300 mm.
Over-arm parallel with movement of saddle in vertical plane	12a	0.02 per 300 mm.
Ditto, in horizontal plane	12b	0.02 per 300 mm.
Bore in outer-arm support aligned with over-arm, measured at several distances from main bearing	13	0.02
Bore of cutter arm support for cutter arbor aligned with cutter spindle, measured at several distances from main bearing	14	0.02

For Table of Equivalents in English Measure see page 51

Testing Vertical Milling Machines

3

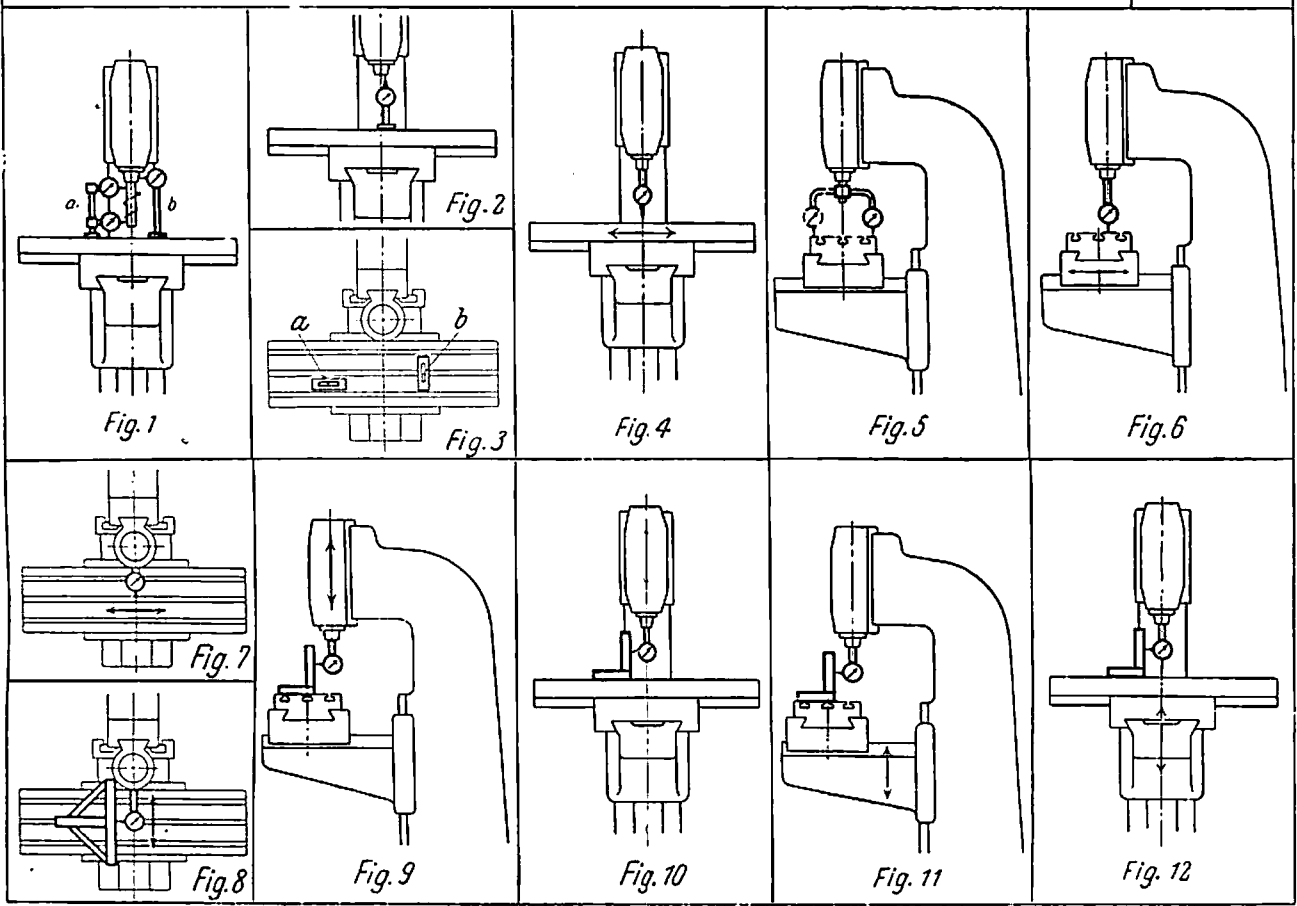

Test Chart for Vertical Milling Machines		No. 3 Chart 1
Test to be Applied	Fig. No.	Permissible Error
Levelling of work table: Work table flat or level in longitudinal direction	3a	mm. ±0.04 per 1,000 mm.
Ditto, in transverse direction .. .. .	3b	±0.04 per 1,000 mm.
Cutter spindle:		
Internal taper of cutter spindle runs true: (1) Nearest to spindle nose .. .. .	1a	0.01
(2) At a distance of 300 mm. (12 in.) ..		0.02
External taper runs out of truth .. .. .	1b	0.01
Cutter spindle for axial slip in machines with up to 50 mm. (2 in.) dia. of front bearing	2	0.01
Over 50 mm. (2 in.) dia. of front bearing		0.02
Work table:		
Rise and fall of table, in its longitudinal movement	4	0.02 per 500 mm. 0.01 per 500 mm.
Addition: over 500 mm. movement 0.01 per 500 mm.		
Work table square with cutter spindle in plane through longitudinal axis of machine (turn round method; table rising towards the front side only)	5	0 to 0.02 per 300 mm.
Work table square with cutter spindle in plane perpendicular to that through longitudinal axis (turn round method)	5	0.02 per 300 mm.

Test Chart for Vertical Milling Machines		No. 3 Chart 2
Test to be Applied	Fig. No.	Permissible Error
Surface of work table parallel with its transverse movement	6	mm. 0.02 per 300 mm.
Centre 'T-slot parallel with' longitudinal table movement	7	0.02 per 300 mm.
Centre T-slot square with transverse table movement	8	0.02 per 300 mm.
Width of T-slots:		
From 10 to 12 mm. ( $\frac{3}{8}$ to $\frac{1}{2}$ in.) .. .. .	..	0 to +0.015
From 14 to 18 mm. ( $\frac{11}{16}$ to $\frac{3}{4}$ in.) .. .. .	..	0 to +0.02
Over 18 mm. ( $\frac{3}{4}$ in.) .. .. .	..	0 to +0.025
Column:		
Vertical adjustment of cutter slide square with work table in plane through longitudinal axis of machine (table rising towards the front side)	9	0 to 0.02 per 300 mm.
Ditto, in plane perpendicular to that through longitudinal axis	10	0.02 per 300 mm.
Column ways for knee square with work table, incline towards front and rear side, respectively	11	0.02 per 300 mm.
Ditto, lateral incline .. .. .	12	0.02 per 300 mm.

For Table of Equivalents in English Measure see page 51

## Testing Thread Milling Machines

4

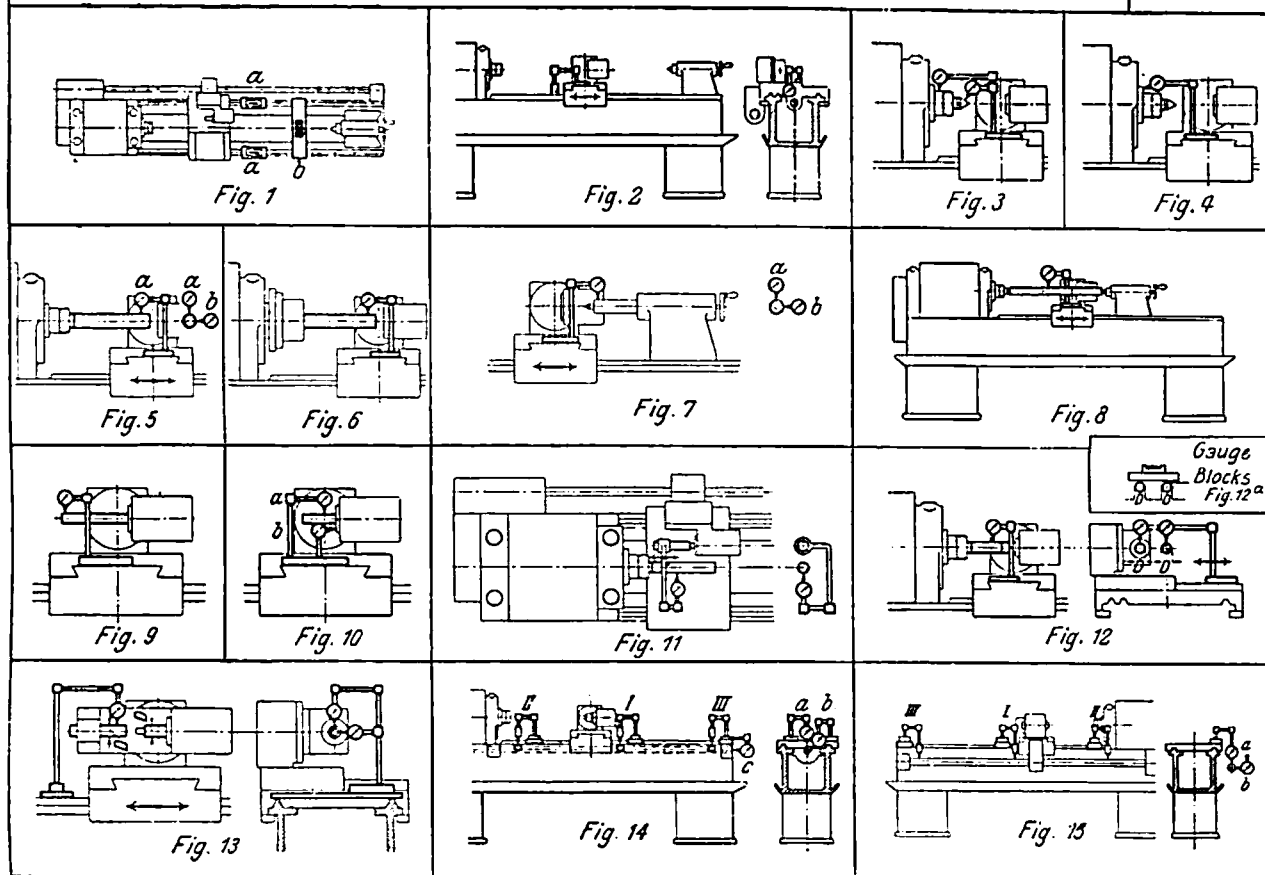

Test Chart of the Working Accuracy of Milling Machines		Machines No. 1, 2, 3
Test to be Applied	Fig. No.	Permissible Error
<b>Working accuracy of:</b>		
1. Horizontal and Universal milling machines, knee-type— Slab-milling, finishing cut* surface is plane Facing by cutter head or end mill ..		0.025 per 300 mm. 0.015 per 300 mm. 0.01 mm.
For each 500 mm. (20 in.) more ..		
2. Surface milling machine and plano-type milling machine— Slab milling finishing cut* .. ..		0.02 per 300 mm. 0.015 per 300 mm.
Facing by cutter head .. ..		0.015 per 300 mm.
3. Vertical milling machine— Facing-finishing cut* .. ..		0.015
Slab milling .. ..		0.025 per 300 mm. 0.02 per 300 mm.
For all types—		
(a) Facing the two parallel surfaces of a rigid block, deviation from parallelism		0.02 per 300 mm.
(b) Two surfaces at right angles ..		0.03 per 300 mm.
* The work piece to be finished should be at least 3 in. by 3 in. by 16 in. For longer pieces, 4 in. by 4 in. by 30 in. The clamping of the block should permit the test to be completed in one setting		
The eccentricity of the milling cutter when in position should not be more than		0.05 mm.

Test Chart for Thread Milling Machines		No. 4 Chart 1
Tests to be Applied	Fig. No.	Permissible Error
<b>Bed:</b>		
Bed straight in longitudinal direction (convex only)	1a	mm. 0 to 0.02 per 1,000 mm.
Bed level in transverse direction ..	1b	±0.02 per 1,000 mm.
No twist permitted		
Tailstock Vees parallel with movement of carriage	2	0.02 per 1,000 mm.
<b>Headstock:</b>		
Centre point for true running .. ..	3	0.01
Centring sleeve for true running ..	3	0.01
Axial slip of work spindle .. ..	4	0.005
In two opposite positions		
Taper of work spindle runs true:	5a	0.01 0.02
(1) Nearest to spindle nose .. ..		
(2) At a distance of 300 mm. (12 in.)		
Work spindle parallel with bed in vertical plane (rising towards the free end of mandrel)	5a	0 to 0.02 per 300 mm.
Ditto, in horizontal plane (front end inclined towards the direction of cutting pressure)	5b	0 to 0.02 per 300 mm.
Chuck runs out of truth, measured on chucked mandrel, 300 mm. (12 in.) in length	6	0.03

For Table of Equivalents in English Measure see page 51

Test Chart for Thread Milling Machines		No. 4 Chart 2
Test to be Applied	Fig. No.	Permissible Error
<b>Tailstock:</b> Tailstock sleeve parallel with bed in vertical plane (rising towards the free end)	7a	mm. 0 to 0.02 per 100 mm.
Ditto, in horizontal plane (front end inclined towards the direction of cutting pressure)	7b	0 to 0.01 per 100 mm.
Axis of tailstock at same height as headstock axis (tailstock high only)	8	0 to 0.02
<b>Cutter slide:</b> Taper of cutter spindle runs true; maximum amount by which mandrel 300 mm. (12 in.) in length runs out at end	9	0.02
Cutter spindle for true running (for machines without internal taper)	10a	0.01
Cutter spindle for axial slip In two opposite positions	10b	0.005
Cutter spindle parallel with work spindle in horizontal plane (at free end of work spindle inclined towards cutter spindle)	11	0 to 0.02 per 300 mm.
Cutter spindle level with work spindle for machines up to 150 mm. (6 in.) height of centres	12	0.02
Over 150 mm. (6 in.) height of centres		0.05
Bore of outer cutter support aligned with cutter spindle	13	0.02

Test Charts for Thread Milling Machines		No. 4 Chart 3
Test to be Applied	Fig. No.	Permissible Error
<b>Lead screw and cutter driving shaft:</b> Bearings of lead screw aligned with each other (axis of bearings parallel with bed ways) in vertical plane (measurements taken in positions II and III)	14a	mm. 0.1
Ditto, in horizontal plane	14b	0.1
Bearings of lead screw aligned with half nut in vertical plane (measurements taken with closed half nut, cutter slide in the middle position or halfway along bed, position I being the starting measurement)	14a	0.15
Ditto, in horizontal plane	14b	0.15
Lead screw for axial slip for machines with up to 150 mm. (6 in.) height of centres	14c	0.005
Over 150 mm. (6 in.) height of centres		0.01
Accuracy of pitch of lead screw is assured within		0.03 per 300 mm.
Front and rear bearings of shaft driving the cutter aligned with each other and with cutter slide bearing (axis of bearings parallel with bed ways) in vertical plane. (Position I is the starting measurement, cutter slide in middle position of halfway along bed)	15a	0.15
Ditto, in horizontal plane	15b	0.15
<b>Working accuracy: total error—</b> Length of 1,000 mm. (40 in.)		±0.08
Length of 300 mm. (12 in.)		±0.03
Measured from 100 to 100 mm. (4 in. to 4 in.)		±0.02

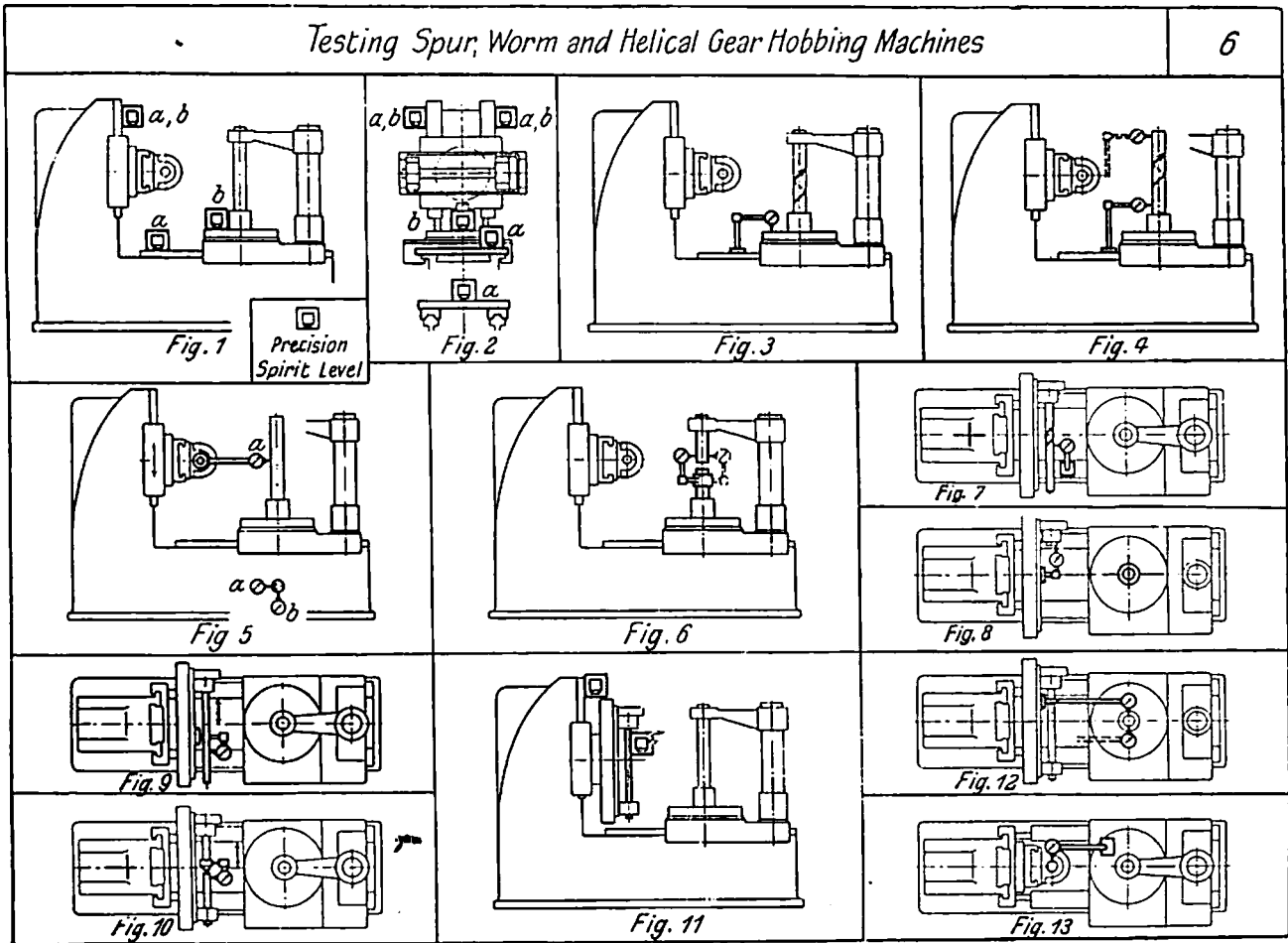

For Table of Equivalents in English Measure see page 51

Test Chart for Spur, Worm and Helical Gear-hobbing Machines		No. 6 Chart 1
Test to be Applied	Fig. No.	Permissible Error
Guide-ways for cutter slide square with work table guide-ways in plane through longitudinal axis of machine (upper end of cutter slide guides inclined towards work arbor only)	1a	mm. 0 to 0.02 per 300 mm.
Ditto, in plane perpendicular to that through longitudinal axis	2a	±0.015 per 300 mm.
Work table: Table runs out of truth . . . . .	3	0.01 per 300 mm. in diam.
Work table square with guide-ways for cutter slide in plane through longitudinal axis of machine (upper end of cutter slide ways inclined towards work arbor)	1b	0 to 0.02 per 300 mm.
Ditto, in plane perpendicular to that through longitudinal axis	2b	0.015 per 300 mm.
Work arbor runs true; maximum amount by which mandrel 300 mm. (12 in.) in length runs out at end	4	0.01
Work arbor parallel with travel of cutter slide in plane through longitudinal axis of machine (upper end inclined towards the cutter slide ways)	5a	0 to 0.02 per 300 mm.
Ditto in plane perpendicular to that through longitudinal axis	5b	0.02 per 300 mm.

Test Chart for Spur Worm and Helical Gear-hobbing Machines		No. 6 Chart 2
Test to be Applied	Fig. No.	Permissible Error
Arm bracket aligned with work arbor, measured at several positions of bracket (turn round method)	6	mm. 0.02
Cutter slide: Taper of cutter spindle runs true; maximum amount by which mandrel 300 mm. (12 in.) in length runs out at end	7	0.02
Cutter spindle for axial slip . . . . . In two opposite positions	8	0.005
Cutter spindle parallel with surface of cutter slide	9	0.02 per 300 mm.
Outer support of cutter arbor aligned with cutter spindle	10	0.02
Cutter spindle parallel with guide-ways for cutter slide, with arbor in perpendicular position	11	0.02 per 300 mm.
Axis of swivelling cutter slide off-set with respect to work arbor (turning round of cutter slide)	12	0.03
Axis of swivelling cutter slide off-set with respect to cutter arbor	13	0.03

Test Chart for Spur, Worm and Helical Gear-hobbing Machines		No. 6 Chart 3
Test to be Applied	Fig. No.	Permissible Error
Dividing wheel: Maximum permissible individual pitch error of dividing wheel, measured from tooth to tooth, proportionate to pitch: At 12 mm. (½ in.) pitch . . . . . " 20 " (¾ in.) " . . . . . " 25 " (1 in.) " . . . . .		mm. 0.01 0.015 0.02
Maximum permissible total pitch error of dividing wheel (amplitude in the diagram of errors = algebraic sum of the maximum + deviation and maximum - deviation from the correct basic pitch value) is assured for diameters: Up to 500 mm. (20 in.) . . . . . From 500 to 1,000 mm. (20 to 40 in.) " 1,000 " 2,000 " (40 " 80 " ) " 2,000 " 3,000 " (80 " 120 " )		0.08 0.09 to 0.15 0.16 " 0.18 0.19 " 0.25
For gears cut on the machine, the following accuracies measured from tooth to tooth are assured, in diameters: Up to 500 mm. (20 in.) . . . . . From 500 to 1,000 mm. (20 to 40 in.) " 1,000 mm. and over (40 in.) . . . . .		0.0125 to 0.02 0.021 to 0.025 0.03
Teeth parallel to axis: { Up to 300 mm. dia. . . . . Over " " . . . . .		0.008 to 0.012 for 75 mm. width 0.02 to 0.035 per 150 mm. width
Eccentricity { Up to 200 mm. dia. . . . . after 201 to 500 mm. dia. . . . . cutting: Over 500 mm. dia. . . . . Shape of tooth up to 300 mm. (12 in.) dia. " " " over 300 mm. (12 in.) dia.		0.012 to 0.02 0.021 to 0.03 0.04 0.005 to 0.01 0.015

TABLE OF EQUIVALENTS			
1. For Converting Mm. Tolerances into Inch Tolerances			
Mm.	Inch	Mm.	Inch
0.01	0.0004	0.06	0.0024
0.015	0.0006	0.1	0.0040
0.02	0.0008	0.15	0.0060
0.025	0.0010	0.2	0.0080
0.03	0.0012	0.25	0.0100
0.04	0.0016	0.3	0.0120
0.05	0.0020		
2. Metric Reference Lengths into Inch Reference Lengths			
Mm.	Inches	Mm.	Inches
100	4	500	20
300	12	1,000	40
3. Metric Tolerances Referred to 300, 500 and 1,000 Mm. into Inch Tolerances Referred to 1 Foot and 3 Feet			
Mm.	Inch per Foot	Inch per 3 Feet	
0.01 per 100 mm.	0.00120	0.00360	
0.01 " 300 "	0.00040	0.00120	
0.015 " 300 "	0.00060	0.00180	
0.02 " 300 "	0.00080	0.00240	
0.02 " 500 "	0.00048	0.00144	
0.02 " 1,000 "	0.00024	0.00072	
0.03 " 300 "	0.00120	0.00360	
0.04 " 1,000 "	0.00048	0.00144	

# Testing Gear Shapers

7

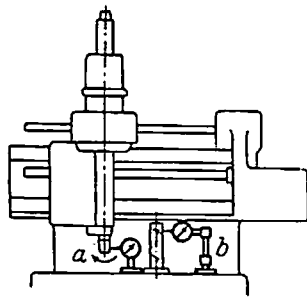

Fig. 1

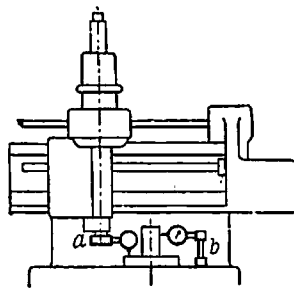

Fig. 2

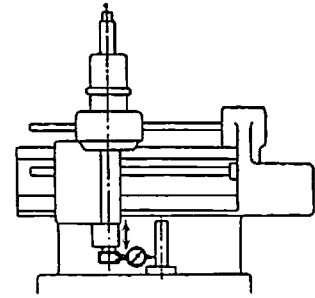

Fig. 3

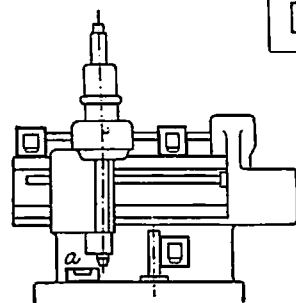

Fig. 4

Precision Spirit Level

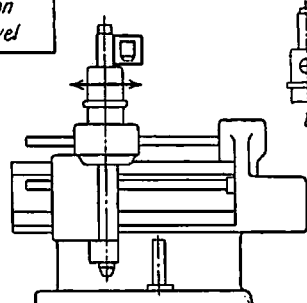

Fig. 5

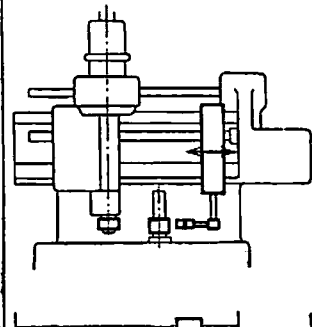

Fig. 6

Test Chart for Gear Shapers		No. 7 Chart 1
Test to be Applied	Fig. No.	Permissible Error
Spirit level (a) on faceplate; along and across	4a	mm. 0.04 per 1,000 mm.
Saddle and work faceplate: Cutter arbor for true running . . . . .	1a	0.01
Work arbor runs true; maximum amount by which mandrel with a max. length of 300 mm. (12 in.) runs out at end	1b	0.01
Face of the faceplate for true running (for machines with work table only) . .	2a	0.02 per 300 mm. in diam.
Faceplate bore for true running . . . . .	2b	0.01
Work arbor parallel with ram guide, measured at two surface lines of mandrel at right angles with each other For machines up to 150 mm. (about 6 in.) length of stroke	3	0.01
From 150 to 300 mm. (about 6 to 12 in.) length of stroke		0.015
From 300 to 1,200 mm. (about 12 to 48 in.) length of stroke		0.025
Cross rail square with work arbor . . . . .	4	0.02 per 300 mm.
Inclination of saddle in its transverse movement along rail . . . . .	5a	$\pm 0.01$ per 300 mm.
Ditto in plane perpendicular to rail . .	5b	$\pm 0.01$ per 300 mm.

Test Chart for Gear Shapers		No. 7 Chart 2
Test to be Applied	Fig. No.	Permissible Error
Work and cutter arbors equidistant from rail	6	mm. 0.2
Maximum permissible individual pitch error of the dividing wheel, measured from tooth to tooth, proportionate to pitch:		
At 12 mm. ( $\frac{1}{2}$ in.) pitch . . . . .		0.01
„ 20 „ ( $\frac{3}{4}$ in.) „ . . . . .		0.015
„ 25 „ (1 in.) „ . . . . .		0.02
Maximum permissible total pitch error of dividing wheel (amplitude in diagram of errors = algebraic sum of maximum + deviation and maximum - deviation from correct basic pitch value) for diameters:		
Up to 500 mm. (20 in.) . . . . .		0.08
From 500 to 1,000 mm. (20 to 40 in.)		0.08 to 0.13
„ 1,000 „ 2,000 „ (40 „ 80 „)		0.14 to 0.17
„ 2,000 „ 3,000 „ (80 „ 120 „)		0.18 to 0.20
Working accuracy of machine: Maximum permissible individual pitch error, from tooth to tooth, for gears shaped on the machine with diameters:		
Up to 200 mm. (8 in.) . . . . .		0.01
From 200 to 500 mm. (8 to 20 in.) . .		0.02
Over 500 mm. (20 in.) . . . . .		0.025
Teeth are parallel to axis . . . . .		0.01 per 100 mm.
Eccentricity after cutting up to 200 mm. (8 in.)		0.01
From 200 to 500 mm. (8 to 20 in.) . .		0.015
Over 500 mm. (20 in.) . . . . .		0.03
Shape of tooth up to 300 mm. (12 in.) dia.		0.01
„ „ „ over 300 mm. (12 in.) dia.		0.015

Testing Lathes

11, 12, 13

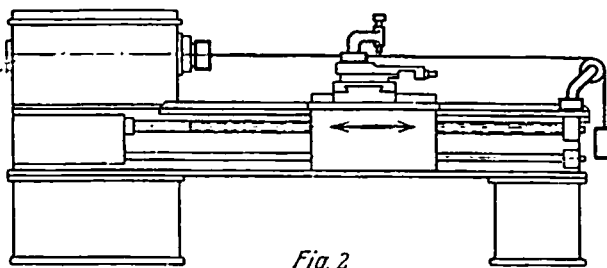
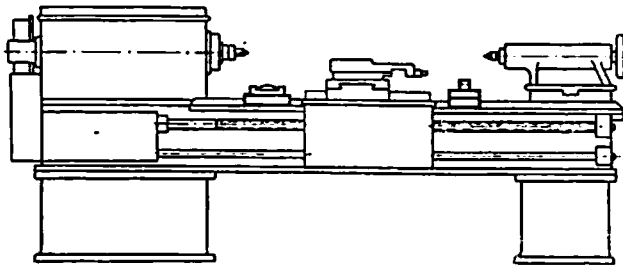

Fig. 2

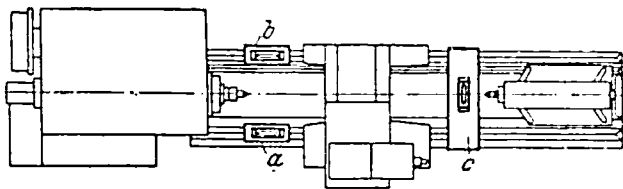

Fig. 1

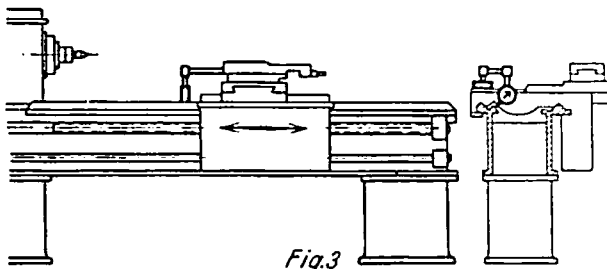

Fig. 3

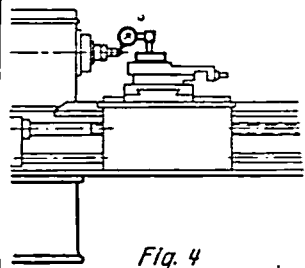

Fig. 4

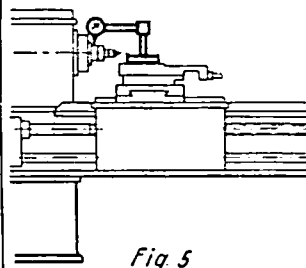

Fig. 5

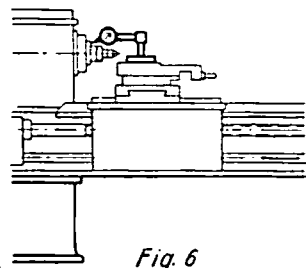

Fig. 6

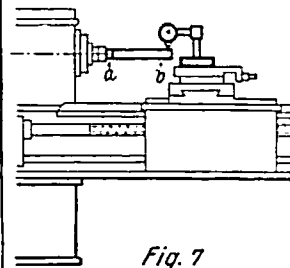

Fig. 7

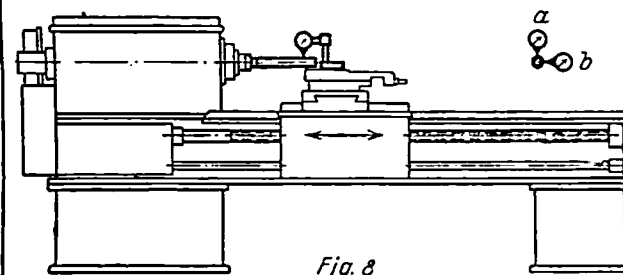

Fig. 8

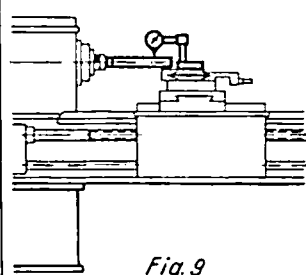

Fig. 9

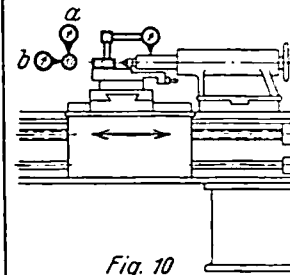

Fig. 10

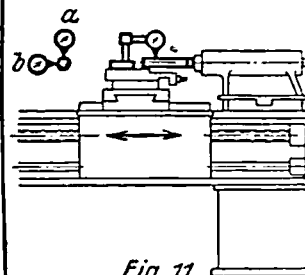

Fig. 11

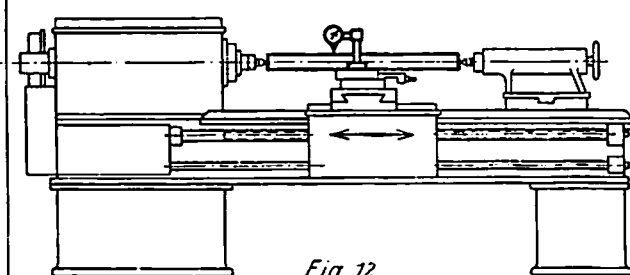

Fig. 12

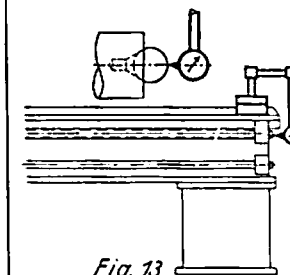

Fig. 13

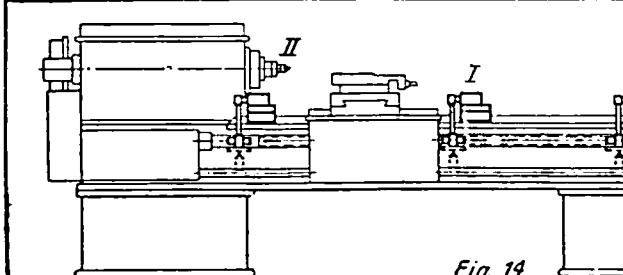

Fig. 14

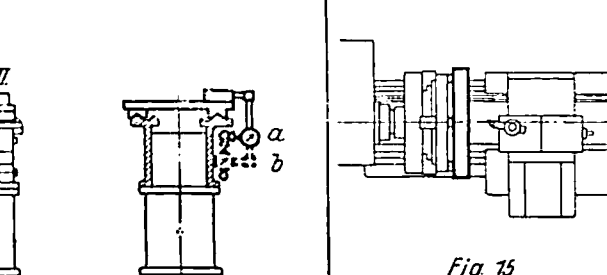

Fig. 15

Test Chart for Finish Turning Lathes up to 400 mm. (about 15½ in.) Height of Centres		No. 11 Chart 1
Test to be Applied	Fig. No.	Permissible Error
Bed: Bed straight in long. direction; apron side (convex only)	1a	mm. 0 to 0.02 per 1,000 mm.
Ditto, opposite side (concave only)	1b	0.02 per 1,000 mm.
Bed level in transverse direction	1c	±0.02 per* 1,000 mm.
Straightness of slide ways (for machines of more than 3 m. (10 ft.) turning length only; measurements taken by measuring taut wire and microscope or long straight edge)	2	0.02 per 1,000 mm.
Tailstock guideways parallel with movement of carriage	3	0.02 per 1,000 mm.
Work spindle: Centre point for true running	4	0.01
Centring sleeve for true running	5	0.01
Work spindle for axial slip, measured at 2 points, displaced by 180°	6	0.01
Taper of work spindle runs true: (1) Nearest spindle nose (2) At a distance of 300 mm. (12 in.)	7	0.01 0.03
Work spindle parallel with bed in vertical plane (rising towards the free end of mandrel only)	8a	0 to 0.02 per 300 mm.
*Either + or - on full length, no twist permitted.		

Test Chart for Finish Turning Lathes up to 400 mm. (about 15½ in.) Height of Centres		No. 11 Chart 2
Test to be Applied	Fig. No.	Permissible Error
Work spindle parallel with bed in horizontal plane (free end of mandrel inclined towards the direction of tool pressure)	8b	mm. 0 to 0.02 per 300 mm.
Carriage: Movement of upper slide parallel with workspindle in vertical plane (hand feed) When automatic feed is provided: in vertical plane in horizontal plane	9	0.03 per 150 mm. 0.03 per 300 mm. 0.02 per 300 mm.
Tailstock: Tailstock sleeve parallel with bed in vertical plane (front end rising)	10a	0 to 0.02 per 100 mm.
Ditto, in horizontal plane (front end inclined towards the direction of tool pressure)	10b	0 to 0.01 per 100 mm.
Cone of sleeve parallel with bed in vertical plane (free end of mandrel rising)	11a	0 to 0.03 per 300 mm.
Ditto, in horizontal plane (free end of mandrel inclined towards direction of tool pressure)	11b	0 to 0.02 per 300 mm.
Axis of centres (mandrel between centres) parallel with bed in vertical plane (mandrel rising towards tailstock end)	12	0 to 0.02
Lead screw: Accuracy in pitch of lead screw is assured within		0.03 per 300 mm.

TABLE OF EQUIVALENTS			
1. For Converting Mm. Tolerances into Inch Tolerances			
Mm.	Inch	Mm.	Inch
0.005	0.0002	0.05	0.0020
0.01	0.0004	0.1	0.0040
0.02	0.0008	0.15	0.0060
0.03	0.0012	0.2	0.0080
2. Metric Reference Lengths into Inch Reference Lengths			
Mm.	Inches	Mm.	Inches
100	4	1,000	40
300	12		
3. Metric Tolerances Referred to 300, 500, and 1,000 Mm. into Inch Tolerances Referred to 1 Foot and 3 Feet			
Mm.	Inch per Foot	Inch per 3 Feet	
0.01 per 100 mm.	0.0012	0.0036	
0.01 " 300 "	0.0004	0.0012	
0.01 " 1,000 "	0.00012	0.00036	
0.02 " 300 "	0.0008	0.0024	
0.02 " 1,000 "	0.00024	0.00072	
0.03 " 300 "	0.0012	0.0036	
0.03 " 1,000 "	0.00036	0.00108	
0.04 " 300 "	0.00160	0.00480	
0.04 " 1,000 "	0.00048	0.00144	
0.05 " 1,000 "	0.00060	0.00180	
0.06 " 1,000 "	0.00072	0.00216	

Test Chart for Finish Turning Lathes up to 400 mm. (about 15½ in.) Height of Centres		No. 11 Chart 3
Test to be Applied	Fig. No.	Permissible Error
Lead screw for axial slip	13	mm. 0.01
Lead screw bearings aligned with each other (axis of bearings parallel with bed ways) in vertical plane (measurements taken in positions II and III)	14a	0.1
Ditto, in horizontal plane	14b	0.1
Lead screw bearings aligned with half nut in vertical plane (measurements taken with closed half nut, carriage in middle position or halfway along bed, position I serving as starting point)	14a	0.15
Ditto, in horizontal plane	14b	0.15
Working accuracy of machine: Lathe turns round within		0.01
Lathe turns cylindrically: (a) Work between centres within (b) Work held in chuck within For each 1,000 mm. (40 in.) 0.01 mm. addition up to 0.05 mm. max.		0.02 per 300 mm. 0.02 per 200 mm.
Lathe faces (hollow or concave only) within	15	0 to 0.02 per 300 mm. in diam.
Thread cut on 50 mm. (2 in.) length		±0.02 per 50 mm.



Test Chart for Finish Turning Lathes with Height of Centres from over 400 to 800 mm. (about 15½ to 32 in.)		No. 12 Chart 1
Test to be Applied	Fig. No.	Permissible Error
mm.		
Bed: Bed straight in long. direction; apron side (arched or convex only)	1a	0 to 0.03 per 1,000 mm.
Ditto, opposite side (concave only) ..	1b	0 to 0.03 per 1,000 mm.
Bed flat or level in transverse direction. No twist permitted	1c	±0.03 per 1,000 mm.
Straightness of bed ways (for machines of more than 3 m. (10 ft.) turning length only; measurements taken by measuring taut wire and microscope or long straight edge)	2	0.02 per 1,000 mm. up to 12ft. 0.03 18ft. 0.04 over 18ft. 0.05
Tailstock guide ways parallel with movement of carriage	3	0.02 per 1,000 mm.
Work spindle:		
Centre point for true running .. ..	4	0.015
Centring sleeve for true running ..	5	0.015
Work spindle for axial slip at 2 points, displaced by 180°	6	0.015
Taper of work spindle runs true: (1) Nearest spindle nose .. .. (2) At a distance of 300 mm. (12 in.)	7	0.015 0.03

Test Chart for Finish Turning Lathes with Height of Centres from over 400 to 800 mm. (about 15½ to 32 in.)		No. 12 Chart 2
Test to be Applied	Fig. No.	Permissible Error
mm.		
Work spindle parallel with bed in vertical plane (rising towards free end of mandrel)	8a	0 to 0.03 per 300 mm.
Ditto, in horizontal plane (free end of mandrel inclined towards the direction of tool pressure only)	8b	0 to 0.02 per 300 mm.
Carriage:		
Movement of upper slide parallel with work spindle in vertical plane (hand feed) When automatic feed is provided:	9	0.03 per 150 mm.
in vertical plane .. .. .		0.03 per 300 mm.
in horizontal plane .. .. .		0.02 per 300 mm.
Tailstock:		
Sleeve parallel with bed in vertical plane (rising towards the front end) ..	10a	0 to 0.03 per 100 mm.
Ditto, in horizontal plane (front end inclined towards the direction of tool pressure only)	10b	0 to 0.01 per 100 mm.
Cone of sleeve parallel with bed in vertical plane (free end of mandrel rising)	11a	0 to 0.03 per 300 mm.
Ditto, in horizontal plane (free end of mandrel inclined towards direction of tool pressure)	11b	0 to 0.02 per 300 mm.
Axis of centres (mandrel between centres) parallel with bed in vertical plane	12	0.03

Test Chart for Finish Turning Lathes with Height of Centres from over 400 to 800 mm. (about 15½ to 32 in.)		No. 12 Chart 3
Test to be Applied	Fig. No.	Permissible Error
mm.		
Lead screw: Accuracy in lead of lead screw is assured within		0.03 per 300 mm.
Lead screw for axial slip .. .. .	13	0.015
Lead screw bearings aligned with each other in vertical plane (axes of bearings parallel with bed ways) (measurements taken in positions II and III)	14a	0.15
Ditto, in horizontal plane .. .. .	14b	0.15
Lead screw bearings aligned with half nut in vertical plane (measurements taken with closed half nut, carriage in the middle position or halfway along bed, position I being the starting measuring point)	14a	0.2
Ditto, in horizontal plane .. .. .	14b	0.2
Working accuracy of machine: Lathe turns round within .. .. .		0.02
Lathe turns cylindrically: (a) Between centres within .. .. . (b) Work held in chuck within .. .. .		0.02 per 300 mm. 0.03 per 300 mm.
Lathe faces (concave only) within ..	15	0 to 0.02 per 300 mm. in diam.
Thread cut on 50 mm. (2 in.) length .. 300 mm. (12 in.) ,, .. .		±0.02 ±0.05

For Table of Equivalents in English Measure see page 54

Test Chart for Toolroom Lathes (Highest Degree of Accuracy) up to 200 mm. (about 8 in.) Height of Centres		No. 13 Chart 1
Test to be Applied	Fig. No.	Permissible Error
Bed: Bed straight in long. direction apron side (arched or convex only)	1a	mm. 0 to 0.02 per 1,000 mm.
Ditto, opposite side .. .. .	1b	0.02 per 1,000 mm.
Bed flat or level in transverse direction. Either + or -; no twist permitted	1c	$\pm 0.02$ per 1,000 mm.
Tailstock guide ways parallel with movement of carriage	3	0.01 per 1,000 mm.
Work spindle: Centre point for true running .. ..	4	0.01
Centring sleeve for true running ..	5	0.005
Internal taper receiving the chuck for true running		0.01
Work spindle for axial slip measured at points, displaced by 180°	6	0.005
Taper of work spindle runs true: (1) Nearest spindle nose .. .. . (2) At a distance of 300 mm. (12 in.)	7	0.008 0.015
Work spindle parallel with bed in vertical plane (rising towards free end of mandrel)	8a	0 to 0.01 per 300 mm.

Test Chart for Toolroom Lathes (Highest Degree of Accuracy) up to 200 mm. (about 8 in.) Height of Centres		No. 13 Chart 2
Test to be Applied	Fig. No.	Permissible Error
Work spindle parallel with bed in horizontal plane (free end of arbor inclined towards direction of tool pressure)	8b	mm. 0 to 0.005 per 300 mm.
Carriage: Movement of upper side parallel with work spindle in vertical plane (hand feed) When automatic feed is provided: in vertical plane .. .. . in horizontal plane .. .. .	9	0.03 per 100 mm. 0.03 per 300 mm. 0.02 per 300 mm.
Tailstock: Sleeve parallel with bed in vertical plane (rising towards front end)	10a	0 to 0.02 per 100 mm.
Ditto, in horizontal plane (front end inclined towards direction of cutting pressure)	10b	0 to 0.01 per 100 mm.
Taper of sleeve parallel with bed in vertical plane (rising towards free end of mandrel)	11a	0 to 0.01 per 300 mm.
Ditto, in horizontal plane (free end of mandrel inclined towards direction of cutting pressure)	11b	0 to 0.01 per 300 mm.
Axis of centres (mandrel between centres) parallel with bed in vertical plane (rising towards tailstock end)	12	0 to 0.02
Lead screw: Accuracy in lead of lead screw is assured within		0.03 per 300 mm.

Test Chart for Toolroom Lathes (Highest Degree of Accuracy) up to 200 mm. (about 8 in.) Height of Centres		No. 13 Chart 3
Test to be Applied	Fig. No.	Permissible Error
Lead screw for axial slip .. .. .	13	0.005 mm.
Lead screw bearings aligned with each other (axes of bearings parallel with bed ways) in vertical plane (measurements taken in positions II and III)	14a	0.1
Ditto, in horizontal plane .. .. .	14b	0.1
Lead screw bearings aligned with half nut in vertical plane (measurements taken with closed half nut, carriage in middle position or halfway along bed, position I serving as starting point)	14a	0.15
Ditto, in horizontal plane .. .. .	14b	0.15
Working accuracy of lathe: Lathe turns round within .. .. . Lathe turns cylindrically: (a) Work between centres within .. (b) Work held in chuck within ..		0.005 0.01 per 300 mm. 0.01 per 150 mm. 0.02 per total length
Lathe faces (concave only) within ..	15	0 to 0.015 per 300 mm. in dia.
Thread cut on 50 mm. (2 in.) length ..		$\pm 0.01$ per 50 mm.

For Table of Equivalents in English Measure see page 54

Testing Relieving Lathes

14

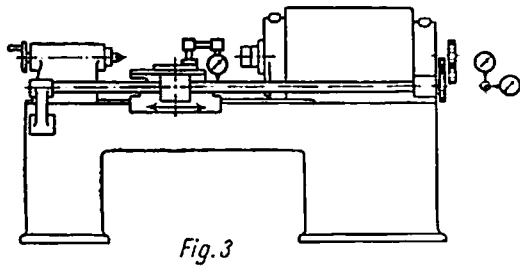
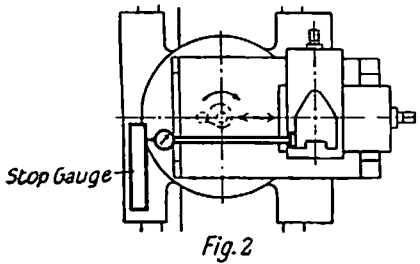
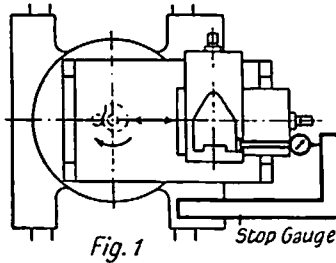

Relieving Lathes

The supplementary measurements of backing-off lathes are to be taken in conjunction with the measurements specified by the test charts 11 and 12 for finish-turning lathes

No. 14

Test to be Applied	Fig. No.	Permissible Error
Does the backing-off slide always return to its initial position ?	1	mm. 0.05
Does the backing-off slide always advance to the same point ?	2	0.01
Driving shaft for backing-off movement parallel with bed	3	0.03 per 300 mm.

TABLE OF EQUIVALENTS

1. For Converting Mm. Tolerances into Inch Tolerances

Mm.	Inch	Mm.	Inch
0.01	0.0004	0.05	0.0020
0.015	0.0006	0.10	0.0040
0.02	0.0008	0.15	0.0060
0.03	0.0012	0.20	0.0080
0.04	0.0016		

2. Metric Reference Lengths into Inch Reference Lengths

Mm.	Inches	Mm.	Inches
20	$\frac{1}{2}$	100	4
25	1	150	6
35	1 $\frac{1}{4}$	300	12
50	2	1,000	40
75	3		

3. Metric Tolerances Referred to Various Lengths into Inch Tolerances Referred to 1 Foot and 3 Feet

Mm.	Inch per Foot	Inch per 3 Feet
0.02 per 1,000 mm.	0.00024	0.00072
0.03 " 1,000 "	0.00036	0.00108
0.04 " 1,000 "	0.00048	0.00144
0.02 " 300 "	0.00080	0.00240
0.03 " 300 "	0.00120	0.00360
0.04 " 300 "	0.00160	0.00480
0.03 " 150 "	0.00240	0.00720
0.15 " 150 "	0.01200	0.03600
0.01 " 100 "	0.00120	0.00360
0.02 " 100 "	0.00240	0.00720
0.1 " 100 "	0.01200	0.03600
0.075 " 75 "	0.01200	0.03600
0.05 " 50 "	0.01200	0.03600
0.04 " 35 "	0.01370	0.04110
0.03 " 25 "	0.01440	0.04320
0.025 " 20 "	0.01500	0.04500

# Testing Facing Lathes

15

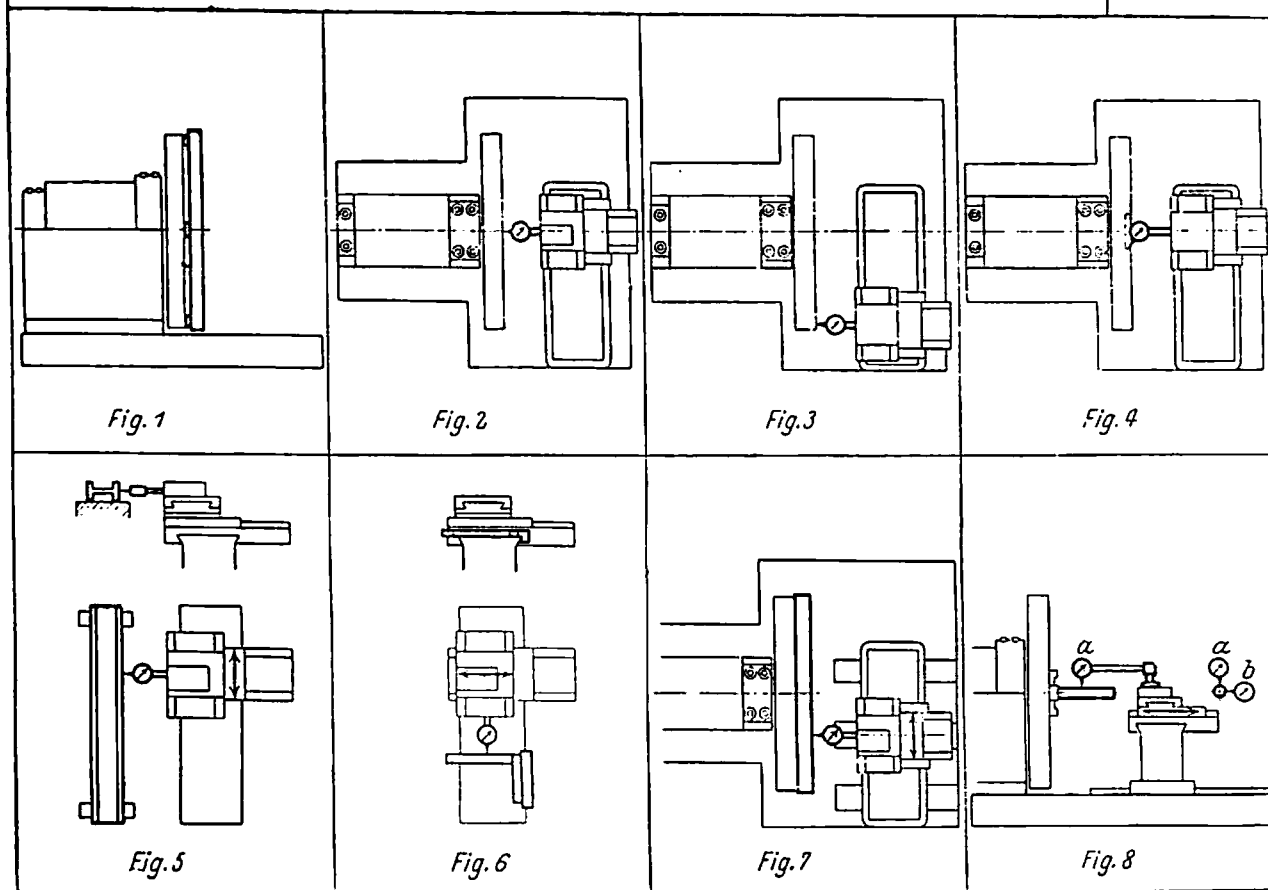

Test Chart for Facing Lathes		No. 15 Chart 1
Test to be Applied	Fig. No.	Permissible Error
Spindle headstock: Faceplate level (hollow or concave only)	1	mm. 0 to 0.04 per 1,000 mm. in diam.
Work spindle for axial slip: Up to 3 m. (10 ft.) dia. to be turned Over 3 m. (10 ft.) dia. to be turned Measured at 2 points, displaced by 180°	2	0.03 0.05
Face of the faceplate runs true . . . . .	3	0.06 per 1,000 mm. in diam.
Faceplate for true running (measured in centring recess) Up to 3 m. (10 ft.) dia. to be turned . . Over 3 m. (10 ft.) dia. to be turned . .	4	0.03 0.05
Carriage: (mounted on separate baseplate) Movement of carriage straight within . .	5	0.03 per 1,000 mm.
Guide ways on compound slide square with each other (for slides without swivel plate only)	6	0.02 per 300 mm.
Carriage: (mounted on common base plate with headstock) Movement of slide parallel with face- plate (concave turning only)	7	0 to 0.05 per 1,000 mm. in diam.

Test Chart for Facing Lathes		No. 15 Chart 2
Test to be Applied	Fig. No.	Permissible Error
Movement of upper slide parallel with axis of faceplate in vertical plane (measured on centred mandrel)	8a	mm. 0.03 per 300 mm.
Ditto, in horizontal plane . . . . .	8b	0.02 per 300 mm.
Working accuracy of machine: Lathe turns round— Up to 3 m. (10 ft.) in turning dia. within Over 3 m. (10 ft. in turning dia. within		0.03 0.05
Lathe turns cylindrically (only for machines with headstock and carriage mounted on common baseplate)— Up to 3 m. (10 ft.) in turning dia. within Over 3 m. (10 ft.) in turning dia. within		0.03 per 300 mm. 0.04 per 300 mm.
Lathe faces (concave; only for machines with headstock and carriage mounted on common baseplate) within		0 to 0.05 per 1,000 mm. in diam.
Surface of baseplate flat . . . . .		±0.02 per 1,000 mm.

For Table of Equivalents in English Measure see page 57

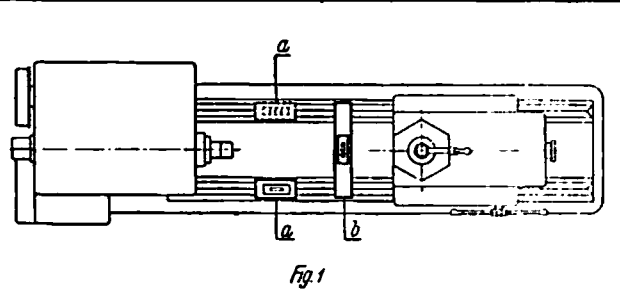

Fig. 1

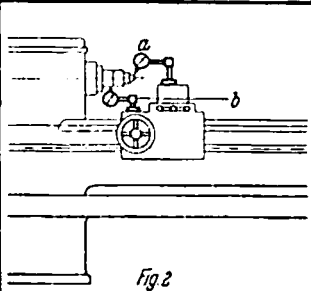

Fig. 2

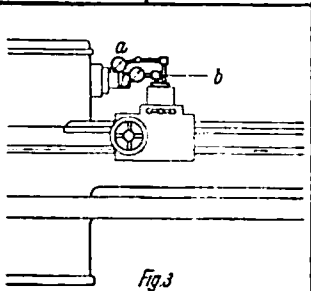

Fig. 3

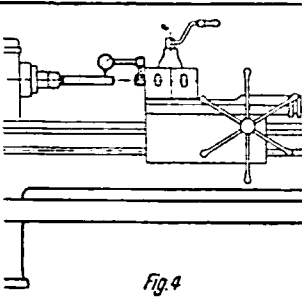

Fig. 4

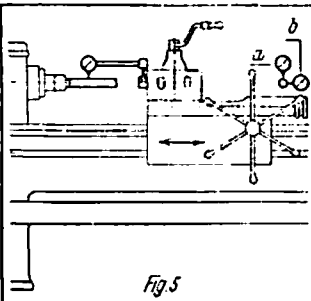
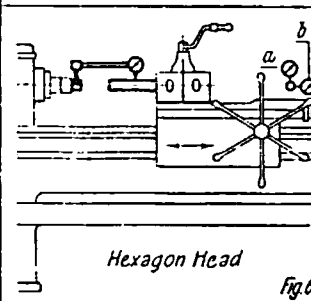
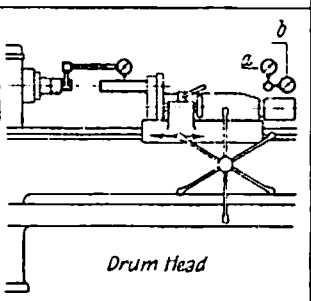

Fig. 5



Hexagon Head



Drum Head

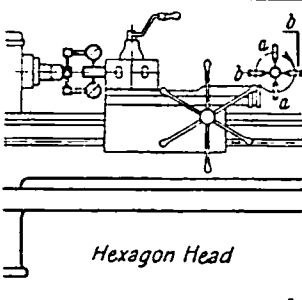

Hexagon Head

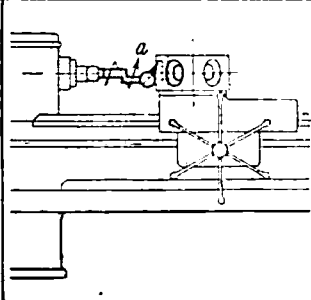

Fig. 8

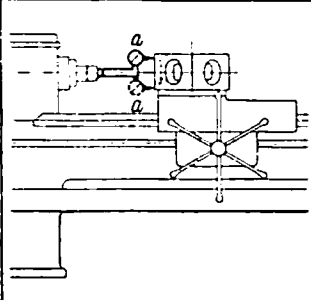
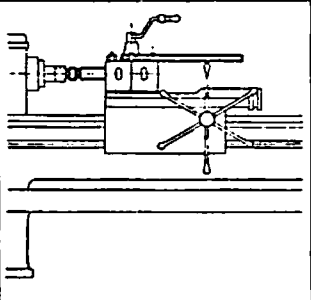
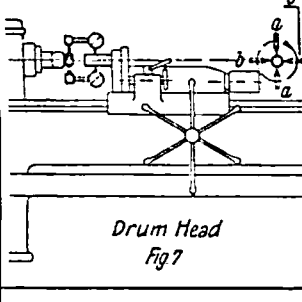

Fig. 9



Hexagon Head  
Fig. 10a



Drum Head  
Fig. 7

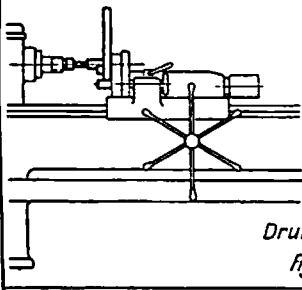
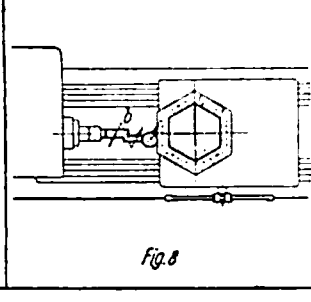

Drum Head  
Fig. 10b

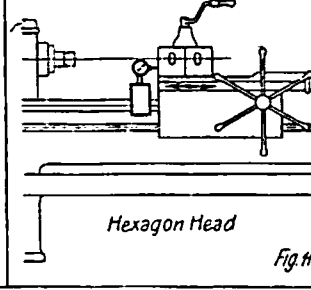
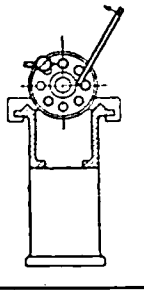

Hexagon Head

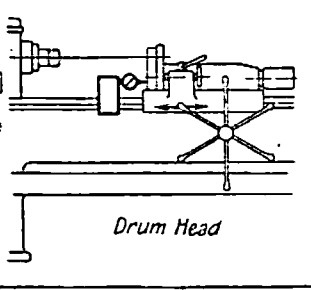

Drum Head

Fig. 11

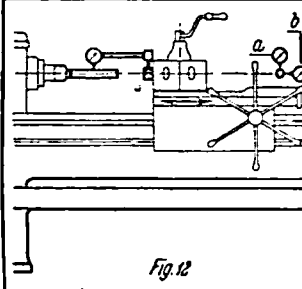

Fig. 12

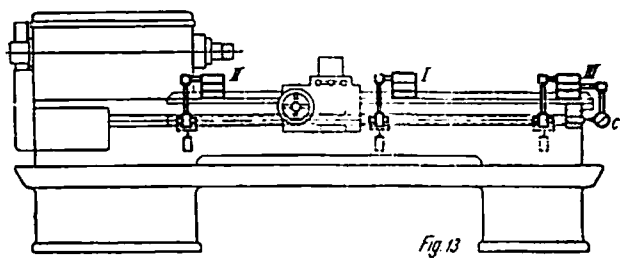

Fig. 13

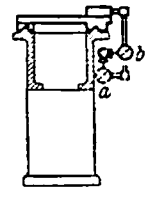

Chart for Turret Lathes arranged for Cylindrical Tool Shanks in the Turret Heads and Single-spindle Automatic Turret Lathes up to 300 mm. (about 12 in.) Height of Centres		No. 16 Chart 1
Test to be Applied	Fig. No.	Permissible Error
Bed: Bed straight in longitudinal direction (convex only)	1a	mm. 0 to 0.02 per 1,000 mm.
Bed flat or level in transverse direction	1b	$\pm 0.02$ per* 1,000 mm.
Work spindle: Centre point for true running . . . .	2a	0.01
Centring sleeve for true running . . .	2b	0.01
Work spindle for axial slip measured at 2 points, displaced by 180°	3a	0.01
Seating for the bar stock chuck for true running	3b	0.01
Taper of work spindle runs true; maximum amount by which mandrel 300 mm. (12 in.) in length runs out at end	4	0.03
Axis of work spindle parallel with bed in vertical plane (rising towards free end of mandrel)	5a	0 to 0.02 per 300 mm.
Ditto, in horizontal plane . . . .	5b	0.02 per 300 mm.
* Either + or - on total length, no twist permitted.		

Test Chart for Turret Lathes arranged for Cylindrical Tool Shanks in the Turret Heads and Single-spindle Automatic Turret Lathes up to 300 mm. (about 12 in.) Height of Centres		No. 16 Chart 2
Test to be Applied	Fig. No.	Permissible Error
Bar stock chuck* runs true, measured on chucked test mandrel† Up to 4 mm. (about $\frac{1}{8}$ in.) dia. of bar	corres to 4	mm. 0.025 per 20 mm. 0.03 per 25 mm. 0.04 per 35 mm. 0.05 per 50 mm. 0.075 per 75 mm. 0.1 per 100 mm. 0.15 per 150 mm.
From 4.1 to 6 mm. (about $\frac{1}{4}$ to $\frac{1}{2}$ in.) dia. of bar		
From 6.2 to 10 mm. (about $\frac{1}{2}$ to $\frac{3}{8}$ in.) dia. of bar		
From 10.2 to 18 mm. (about $\frac{3}{8}$ to $\frac{3}{4}$ in.) dia. of bar		
From 18.5 to 30 mm. (about $\frac{3}{4}$ to 1 $\frac{1}{8}$ in.) dia. of bar		
From 31 to 50 mm. (about 1 $\frac{1}{2}$ to 2 in.) dia. of bar		
Over 50 mm. (about 2 in.) dia. of bar		
* Each test is the average result of five successive chuckings and measurements † The cylindrically ground test mandrel is below size by 10 PE as compared with the basic diameter. [1 PE = 1 standard fit unit = $0.005 \times \sqrt{\text{dia.}}$ (in the metric system).]		
Turret head slide: Tool holes parallel with bed in vertical plane	6a	0.02 per 300 mm.
Ditto in horizontal plane . . . .	6b	0.02 per 300 mm.

Test Chart for Turret Lathes arranged for Cylindrical Tool Shanks in the Turret Heads and Single-spindle Automatic Turret Lathes up to 300 mm. (about 12 in.) Height of Centres		No. 16 Chart 3
Test to be Applied	Fig. No.	Permissible Error
Tool holes aligned with work spindle in vertical plane (tool holes higher than work spindle) For machines admitting up to 30 mm. (1 $\frac{1}{8}$ in.) dia. of bar Over 30 mm. dia. of bar . . . .	7a	mm. 0 to 0.02 0 to 0.03
Ditto, in horizontal plane . . . . For machines admitting up to 30 mm. (1 $\frac{1}{8}$ in.) dia. of bar Over 30 mm. dia. of bar . . . .	7b	0.02 0.03
Centring recesses for tool holders aligned with work spindle in vertical plane (recesses higher than work spindle; tests made by swing round method). For machines admitting up to 30 mm. (1 $\frac{1}{8}$ in.) dia. of bar Over 30 mm. dia. of bar . . . .	8a	0 to 0.02 0 to 0.03
Ditto, in horizontal plane for machines Up to 30 mm. (1 $\frac{1}{8}$ in.) dia. of bar . . . Over 30 mm. dia. of bar . . . .	8b	0.02 0.03

Test Chart for Turret Lathes arranged for Cylindrical Tool Shanks in the Turret Heads and Single-spindle Automatic Turret Lathes up to 300 mm. (about 12 in.) in Height of Centres		No. 16 Chart 4
Test to be Applied	Fig. No.	Permissible Error
Hexagon head faces (clamping surfaces for the tool holders) square with work spindle in vertical plane (tests made by swing-round method) For machines admitting up to 30 mm. (1 $\frac{1}{8}$ in.) dia. of bar (radius of dial holding arm = 50 mm. (2 in.)) Over 30 mm. dia. of bar (radius of dial holding arm = 75 mm. (3 in.))	9a	mm. 0.02 per 100 mm. 0.03 per 150 mm.
Ditto, in horizontal plane for machines admitting up to 30 mm. (1 $\frac{1}{8}$ in.) dia. of bar (radius of dial holding arm = 50 mm. (2 in.)) Over 30 mm. dia. of bar (radius of dial holding arm = 75 mm. (3 in.))	9b	0.02 per 100 mm. 0.03 per 150 mm.
Turret head is free from play or clearance in its bearings and locking notches. Permissible amount of rotation about its axis, measured at the end of a mandrel 200 mm. (about 8 in.) in length (lever arm about 0.5 m. (20 in.); force about 5 kg. (10 lb.))	10	0.015
Rough limit of automatically-tripped longitudinal motion always at the same point within	11	0.1
Fine limit of longitudinal motion tripped by positive dog stop (if wanted, using reading of pointer)	11	0.01

For Table of Equivalents in English Measure see page 57

Test Chart for Turret Lathes arranged for Cylindrical Tool Shanks in the Turret Heads and Single-spindle Automatic Turret Lathes up to 300 mm. (about 12 in.) Height of Centres		No. 16 Chart 5
Test to be Applied	Fig. No.	Permissible Error
Movement of upper turret head (capstan) slide parallel with work spindle in vertical plane (mandrel in spindle rising only towards the free end) For machines with upper turret head slide admitting up to 30 mm. (1 1/8 in.) dia. of bar Over 30 mm. dia. of bar	12a	mm.  0 to 0.01 per 100 mm.  0 to 0.02 per 100 mm.
Ditto, in horizontal plane for machines admitting up to 30 mm. (1 1/8 in.) dia. of bar Over 30 mm. dia. of bar	12b	0.01 per 100 mm.  0.02 per 100 mm.
Lead screw: Accuracy in lead of lead screw is assured within		0.03 per 300 mm.
Bearings of lead screw aligned with each other (axes of bearings parallel with bed ways in vertical plane. Measurements taken in positions II and III)	13a	0.1
Ditto, in horizontal plane	13b	0.1
Bearings of lead screw aligned with half nut in vertical plane (measurements taken with the half-nut closed, cutting-slide in middle position or half way along bed, starting measurement made in position I)	13a	0.15
Ditto, in horizontal plane	13b	0.15

Test Chart for Turret Lathes arranged for Cylindrical Tool Shanks in the Turret Heads and Single-spindle Automatic Turret Lathes up to 300 mm. (about 12 in.) Height of Centres		No. 16 Chart 6
Test to be Applied	Fig. No.	Permissible Error
Lead screw for axial slip	13c	mm. 0.01
Working accuracy of machine: Lathe turns round with turret head slide within		0.01
Ditto, with cutting-off slide within		0.01
Lathe turns cylindrically with turret head slide within (mandrel mounted in bar chuck)		0.03 per 300 mm.
Ditto, with cutting-off slide within		0.03 per 300 mm.
Lathe faces with turret head slide (concave only)		0 to 0.02 per 300 mm. in diam.
Ditto, with cutting-off slide (concave only)		0 to 0.02 per 300 mm. in diam.

Supplementary Test Chart for Turret Lathes with Hollow Turret Heads provided with Centring Recesses for the Tool Holders up to 300 mm. (12 in.) Height of Centres		No. 16a Chart 1
The measurements and tolerances under the headings: Bed, work spindle, lead screw and working accuracy are the same as in the test chart 16		
Test to be Applied	Fig. No.	Permissible Error
Turret slide: Centring recesses for tool holders aligned with work spindle in vertical plane (recesses higher than work spindle, tests are made by the swing round method) For machines admitting up to 30 mm. (1 1/8 in.) dia. of bar Over 30 mm. dia. of bar	8a	mm.  0 to 0.02  0 to 0.03
Ditto, in horizontal plane For machines admitting up to 30 mm. (1 1/8 in.) dia. of bar Over 30 mm. dia. of bar	8b	0.02  0.03
Front faces of hexagon turret (clamping surfaces for the tool holders) square with work spindle in vertical plane (tests are made by swing-round method) For machines admitting up to 30 mm. (1 1/8 in.) dia. of bar (radius of dial holding arm=50 mm. (2 in.)) Over 30 mm. dia. of bar (radius of dial holding arm=75 mm. (3 in.))	9a	0.02 per 100 mm.  0.03 per 150 mm.

Supplementary Test Chart for Turret Lathes with Hollow Turret Heads provided with Centring Recesses for the Tool Holders up to 300 mm. (12 in.) Height of Centres		No. 16a Chart 2
Test to be Applied	Fig. No.	Permissible Error
Front faces of hexagon turret (clamping surfaces for the tool holders) square with work spindle in horizontal plane For machines admitting up to 30 mm. (1 1/8 in.) dia. of bar (radius of dial holding arm=50 mm. (2 in.)) Over 30 mm. dia. of bar (radius of dial holding arm=75 mm. (3 in.))	9b	mm.  0.02 per 100 mm.  0.03 per 150 mm.
Turret head is free from play or clearance in its bearing and locking notches. Permissible amount of rotation about the axis, measured at the end of a mandrel 300 mm. (12 in.) long (length of lever arm about 0.5 m. (20 in.); force about 5 kg. (10 lb.))	10	0.03
Rough limit of automatically tripped longitudinal motion always at the same point within	11	0.1
Fine limit of longitudinal motion tripped by positive stop within (if wanted, using reading of pointer)	11	0.01

For Table of Equivalents in English Measure see page 57

Test Chart for Turret Lathes arranged for Cylindrical Tool Shanks in the Turret Heads and Single-spindle Automatic Turret Lathes with more than 300 mm. (12 in.) Height of Centres		No. 17 Chart 1
Test to be Applied	Fig. No.	Permissible Error
Bed: Bed straight in long. direction (convex only)	1a	mm. 0 to 0.03 per 1,000 mm.
Bed flat or level in transverse direction. No twist permitted	1b	$\pm 0.02$ per 1,000 mm.
Work spindle: Centre point for true running .. ..	2a	0.02
Centring sleeve for true running ..	2b	0.02
Work spindle for axial slip measured at 2 points, displaced by 180°	3a	0.02
Seating of bar stock chuck for true running	3b	0.02
Taper of work spindle runs true: maximum amount by which mandrel 300 mm. (12 in.) in length runs out at end	4	0.03
Axis of work spindle parallel with bed in vertical plane (rising towards free end of mandrel)	5a	0 to 0.03 per 300 mm.
Ditto, in horizontal plane .. ..	5b	0.03 per 300 mm.

Test Chart for Turret Lathes arranged for Cylindrical Tool Shanks in the Turret Heads and Single-spindle Automatic Turret Lathes with more than 300 mm. (12 in.) Height of Centres		No. 17 Chart 2
Test to be Applied	Fig. No.	Permissible Error
Bar chuck* runs true measured on chucked mandrel† * Each test is the average result of five successive chuckings and measurements. † The cylindrically ground test mandrel has an undersize of 10 PE as compared with the basic dia. (1 PE=1 standard fit unit=0.005 $\sqrt{\text{dia.}}$ in the metric system.)	Corres. with 4	mm. 0.15 per 150 mm.
Turret head size: Tool holes parallel with bed in vertical plane	6a	0.03 per 300 mm.
Ditto, in horizontal plane .. ..	6b	0.03 per 300 mm.
Tool holes aligned with work spindle in vertical plane (tool holes higher than work spindle)	7a	0 to 0.03
Ditto, in horizontal plane .. ..	7b	0.03
Centring recesses for tool holders aligned with work-spindle in vertical plane (recesses higher than work spindle, tests made by the swing-round method)	8a	0 to 0.03
Ditto, in horizontal plane .. ..	8b	0.03

Test Chart for Turret Lathes arranged for Cylindrical Tool Shanks in the Turret Heads and Single-spindle Automatic Turret Lathes with more than 300 mm. (12 in.) Height of Centres		No. 17 Chart 3
Test to be Applied	Fig. No.	Permissible Error
Front faces of hexagon turret head (clamping surfaces for the tool holders) square with work spindle in vertical plane (test made by the turn-round method with a radius of dial-holding arm = 75 mm. (3 in.))	9a	mm. 0.03 per 150 mm.
Ditto, in horizontal plane .. ..	9b	0.03 per 150 mm.
Turret head is free from play or clearance in its bearing and locking notches. Permissible amount of rotation about its axis, measured at the end of a mandrel 400 mm. (16 in.) long. (Length of lever arm about 1 m. (40 in.); force about 5 kg. (10 lb.))	10	0.05
Rough limit of automatically-tripped long. movement always at the same point within	11	0.15
Fine limit of long. movement tripped by positive stop within (if wanted, using reading of pointer)	11	0.02
Lead screw: Accuracy in lead of lead screw is assured within		0.03 per 300 mm.

Test Chart for Turret Lathes arranged for Cylindrical Tool Shanks in the Turret Heads and Single-spindle Automatic Turret Lathes with more than 300 mm. (12 in.) Height of Centres		No. 17 Chart 4
Test to be Applied	Fig. No.	Permissible Error
Lead screw bearings aligned with each other (axes of bearings parallel with bed ways) in vertical plane (measurements taken in positions II and III)	13a	mm. 0.15
Ditto, in horizontal plane .. ..	13b	0.15
Lead screw bearings aligned with half-nut in vertical plane (measurements made with closed half-nut, cutting-off slide in middle position or halfway along bed, starting measurement taken in position I)	13a	0.2
Ditto, in horizontal plane .. ..	13b	0.2
Lead screw for axial slip .. ..	13c	0.02
Working accuracy of machine: Lathe turns round with turret head slide within		0.02
Ditto, with cutting-off slide within ..		0.02
Lathe turns cylindrically with turret head slide within (mandrel mounted in bar chuck)		0.03 per 300 mm.
Ditto, with cutting-off slide within ..		0.03 per 300 mm.
Lathe faces with turret head slide (concave only) within		0 to 0.03 per 300 mm. in dia.
Ditto, with cutting-off slide (concave only) within		0 to 0.03 per 300 mm. in dia.

For Table of Equivalents in English Measure see page 57



Supplementary Test Chart for Turret Lathes with Hollow Turret Heads provided with Centring Recesses. Height of Centres more than 300 mm. (12 in.)		No. 17A
The measurements and tolerances given under the headings: Bed, work spindle, lead screw and working accuracy are the same as in the test chart 17		
Test to be Applied	Fig. No.	Permissible Error
Turret head slide: Centring recesses for the tool holders aligned with work spindle in vertical plane (centring recesses higher than work spindle; tests made by the turn-round method)	8a	mm. 0 to 0.03
Ditto, in horizontal plane	8b	0.03
Front faces of hexagon turret head (clamping surfaces for the tool holders) square with work spindle in vertical plane (tests made by the turn-round method with a radius of dial holding arm=75 mm. (3 in.))	9a	0.03 per 150 mm.
Ditto, in horizontal plane	9b	0.03 per 150 mm.
Turret head is free from play or clearance in its bearing and locking notches. Permissible amount of rotation about its axis, measured at the end of a mandrel 400 mm. (16 in.) long (length of lever arm=1 m. (40 in.); force about 4 kg. (9 lb.))	10	0.05
Rough limit of automatically-tripped long. movement always at the same point within	11	0.15
Fine limit of long. movement tripped by positive stop within (if wanted, using reading of pointer)	11	0.02

TABLE OF EQUIVALENTS			
1. For Converting Mm. Tolerances into Inch Tolerances			
Mm.	Inch	Mm.	Inch
0.01	0.0004	0.04	0.0016
0.015	0.0006	0.045	0.0018
0.02	0.0008	0.05	0.0020
0.025	0.0010	0.052	0.00205
0.03	0.0012	0.06	0.0024
0.032	0.00126	0.15	0.0060
0.038	0.0015	0.2	0.0080
2. Metric Reference Lengths into Inch Reference Lengths			
Mm.	Inch	Mm.	Inch
20	$\frac{1}{2}$	75	3
25	1	100	4
35	1 $\frac{1}{2}$	150	6
50	2	1,000	40
3. Metric Tolerances Referred to Various Lengths into Inch Tolerances Referred to 1 Foot and 3 Feet			
Mm.	Inch per Foot	Inch per 3 Feet	
0.015 per 100 mm.	0.0018	0.0054	
0.02 " 100 "	0.0024	0.0072	
0.02 " 1,000 "	0.00024	0.00072	
0.025 " 20 "	0.0150	0.0450	
0.03 " 25 "	0.0144	0.0432	
0.03 " 150 "	0.0024	0.0072	
0.04 " 35 "	0.0137	0.0411	
0.05 " 50 "	0.0120	0.0360	
0.075 " 75 "	0.0120	0.0360	
0.1 " 100 "	0.0120	0.0360	
0.15 " 150 "	0.0120	0.0360	
0.01 " 50 "	0.0024	0.0072	
0.01 " 100 "	0.0012	0.0036	
0.015 " 50 "	0.0036	0.0108	
0.03 " 100 "	0.0036	0.0108	

Test Chart for Multi-spindle Automatics having Rotary Work and Stationary Tools		No. 18A Chart 1
Test to be Applied	Fig. No.	Permissible Error
Bed: Bed straight in longitudinal direction No twist permitted.	1a	mm. $\pm 0.02$ per 1,000 mm.
Bed flat or level in transverse direction No twist permitted.	1b	$\pm 0.02$ per 1,000 mm.
Spindle housing and tool carrier: Centring sleeve for true running	2a	0.01
Collar for axial slip	2b	0.01
Seating of bar chuck for true running	2c	0.01
Bar chuck runs out of truth (=amount of eccentricity $\times 2$ )*, measured on chucked test mandrel † Up to 4 mm. ( $\frac{3}{16}$ in.) dia. of bar	3	0.025 per 20 mm. 0.03 per 25 mm. 0.04 per 35 mm. 0.05 per 50 mm. 0.075 per 75 mm. 0.1 per 100 mm. 0.15 per 150 mm.
From 4.1 to 6 mm. ( $\frac{1}{4}$ to $\frac{1}{2}$ in.) dia. of bar		
From 6.2 to 10 mm. ( $\frac{1}{2}$ to $\frac{3}{4}$ in.) dia. of bar		
From 10.2 to 18 mm. ( $\frac{3}{4}$ to $1\frac{1}{4}$ in.) dia. of bar		
From 18.5 to 30 mm. ( $1\frac{1}{4}$ to $1\frac{1}{2}$ in.) dia. of bar		
From 31 to 50 mm. ( $1\frac{1}{2}$ to 2 in.) dia. of bar		
Over 50 mm. (2 in.) dia. of bar		
* Each test is the average result of five successive chuckings and measurements † The cylindrically ground test mandrel has an undersize of 10 PE as compared with the basic diameter. (1 PE = 1 standard fit unit = $0.005 \sqrt{\text{dia.}}$ in the metric system).		

Test Chart for Multi-spindle Automatics having Rotary Work and Stationary Tools		No. 18A Chart 2
Test to be Applied	Fig. No.	Permissible Error
Work spindles spaced around a circle concentric with bearing of spindle carrier	4	mm. 0.025
Work spindles equidistant from each other for machines Up to 50 mm. dia. of bar .. .. Over 50 mm. dia. of bar .. ..	5a	0.04 0.06
Work spindles equidistant from axis of tool carrier (for machines only, where a tool block serving as a main tool carrier is guided along a tool carrier axis)	5b	0.025
Work spindles parallel with movement of tool carrier in vertical plane	6a	0.015 per 100 mm.
Ditto, in horizontal plane .. ..	6b	0.015 per 100 mm.
Work spindles parallel with tool clamping surface (for machines, where tool block is used as main tool carrier)	7a	0.02 per 100 mm.
Work spindles parallel with slot in tool clamping surface (for machines where tool block is used as main tool carrier)	7b	0.02 per 100 mm.

Testing Multi-spindle Automatics  
 With Work Revolving and Tools Stationary

18a

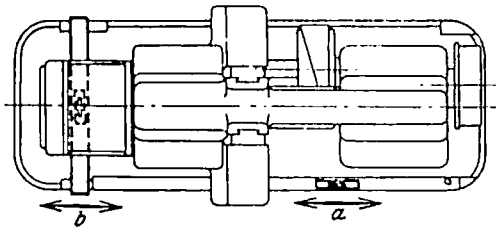

Fig. 1

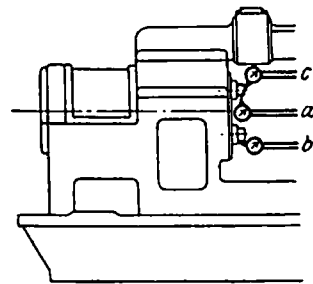

Fig. 2

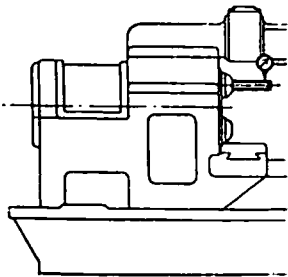

Fig. 3

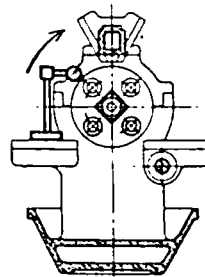

Fig. 4

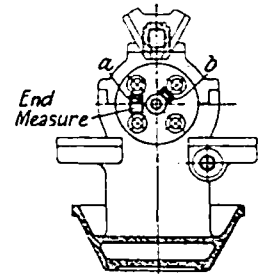

Fig. 5

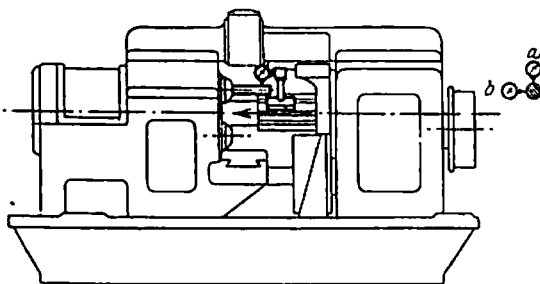

Fig. 6

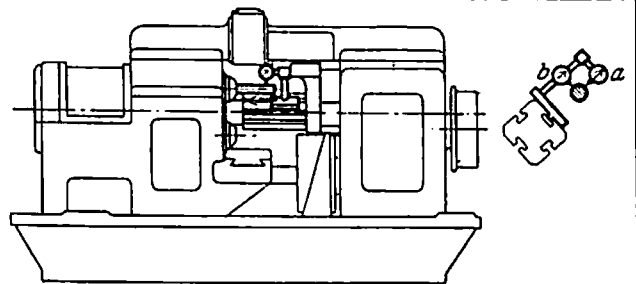

Fig. 7

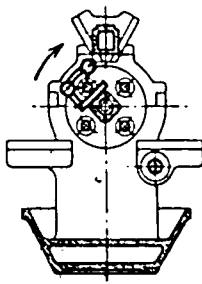

Fig. 8a

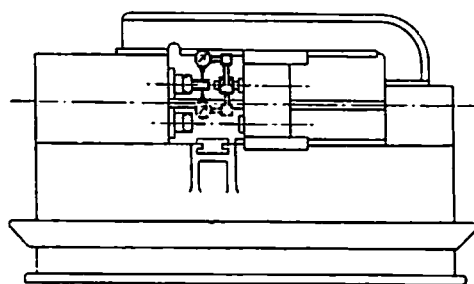

Fig. 8b

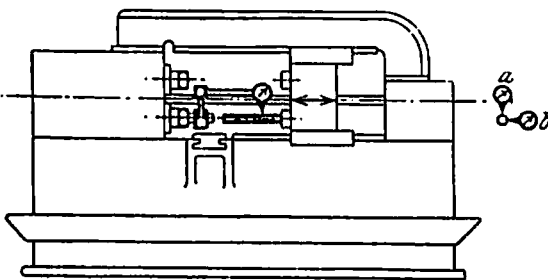
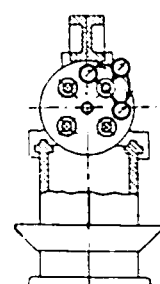

Fig. 9

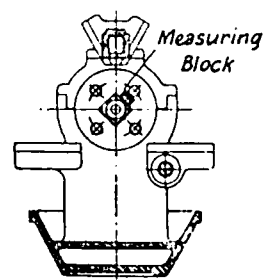

Fig. 10

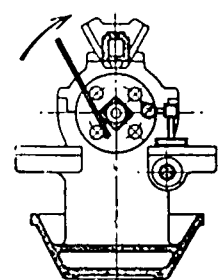

Fig. 11

Test Chart for Multi-spindle Automatics having Rotary Work and Stationary Tools		No. 18A Chart 3
Test to be Applied	Fig. No.	Permissible Error
After indexing, work spindles in the same position relative to 1st tool clamping surface. 2nd tool clamping surface. 3rd tool clamping surface. 4th tool clamping surface. Up to 50 mm. dia. of bar .. .. Over 50 mm. dia. of bar .. .. (For machines where a tool block is used as a main tool carrier)	8a	mm.  ±0.04 ±0.06
Work spindles in line with 1st tool hole. 2nd tool hole. 3rd tool hole. 4th tool hole. Up to 50 mm. dia. of bar .. .. Over 50 mm. dia. of bar .. .. (For machines admitting immediate tool shanks in head)	8b	±0.04 ±0.06
Tool holes parallel with guide of tool carrier in vertical plane .. .. (For machines admitting immediate tool shanks in head)	9a	0.015 per 100 mm.
Ditto, in horizontal plane .. ..	9b	0.015 per 100 mm.
Work spindles equidistant from tool clamping surfaces	10	±0.2

Test Chart for Multi-spindle Automatics having Rotary Work and Stationary Tools		No. 18A Chart 4
Test to be Applied	Fig. No.	Permissible Error
Spindle carrier for freedom from play in its bearing and locking notches. Amount of rotation about axis, measured on a mandrel mounted in a work spindle (length of lever arm approx. 0.5 m. (20 in.))	11	mm. 0.02
Working accuracy of machine: Machine turns round For machines up to 50 mm. dia. of bar For machines over 50 mm. dia. of bar		0.015 0.02
Machine turns cylindrically For machines up to 30 mm. (1 1/8 in.) dia. of bar For machines over 30 mm. dia. of bar		0.015 per 50 mm. dia. 0.03 per 100 mm.
Facing cut with cross slide (hollow only)		0 to 0.01 per 50 mm. dia. 0 to 0.015 per 100 mm. dia.
Work pieces successively taken from the machine vary to the following extent* Up to 18 mm. (3/4 in.) dia. of bar .. From 18.5 to 30 mm. (3/4 to 1 1/8 in.) dia. of bar From 31 to 50 mm. (1 1/4 to 2 in.) dia. of bar From 51 to 80 mm. (2 to 3 1/8 in.) dia. of bar Over 80 mm. .. .. .		0.027 0.035 0.040 0.045 0.055

\*These allowances relate to the corresponding largest diameter bar admitted, I.S.O. fit, quality 8.

Test Chart for Multi-spindle Automatics having Stationary Work and Rotary Tools		No. 18B Chart 1
Test to be Applied	Fig. No.	Permissible Error
Bed: Bed straight in longitudinal direction. .	1a	mm. ±0.02 per 1,000 mm.
Bed flat or level in transverse direction No twist permitted	1b	±0.02 per 1,000 mm.
Headstock and work turret: Axis of turret head parallel with its movement in vertical plane	2a	0.01 per 100 mm.
Ditto, in horizontal plane .. ..	2b	0.01 per 100 mm.
Outer sleeve of tool spindles for true running	3a	0.01
Inner sleeve of tool spindles for true running	3b	0.01
Collar for axial slip .. .. .	3c	0.01
Tool spindles parallel with movement of turret head in vertical plane	4a	0.015 per 100 mm.
Ditto, in horizontal plane .. ..	4b	0.015 per 100 mm.
Tool spindles equidistant from each other	5	0.04
Tool spindles concentric with axis of turret head	6	0.025

Test Chart for Multi-spindle Automatics having Stationary Work and Rotary Tools		No. 18B Chart 2
Test to be Applied	Fig. No.	Permissible Error
Tool spindles in line with .. .. . 1st hole of turret head. 2nd hole of turret head. 3rd hole of turret head. 4th hole of turret head. 5th hole of turret head.	7	mm. ±0.05
Turret head for freedom from play in its bearing and locking notches. Amount of rotation about its axis, measured on a mandrel mounted in the head (length of lever arm approx. 0.5 m. (20 in.))	8	0.03
Working accuracy of machine: Machine turns round For machines up to 50 mm. (about 2 in.) turning diameter* For machines with more than 50 mm. turning diameter		0.02 0.03
Machine turns cylindrically .. .. .		0.03 per 100 mm.

\* The stated turning diameter applies to the total turning length. For short turning lengths the turning diameter is usually considerably larger. Test is made on a diameter with a maximum value equal to the stated turning diameter relating to the total turning length.

For Table of Equivalents in English Measure see page 70

# Testing Multi-spindle Automatics With Work Stationary and Tools Revolving

18b

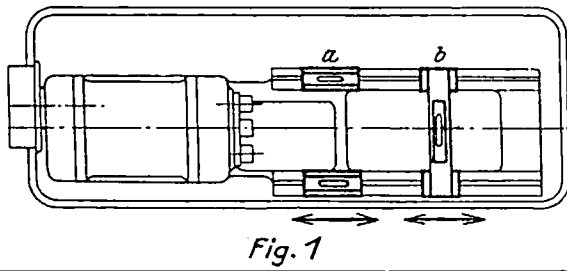

Fig. 1

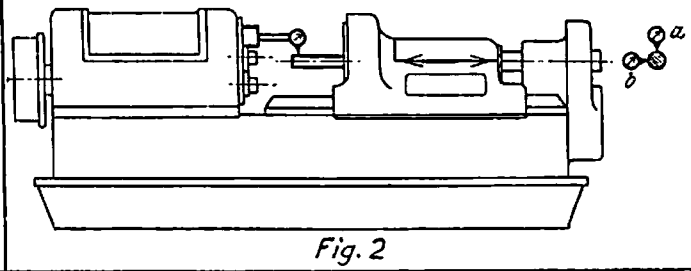

Fig. 2

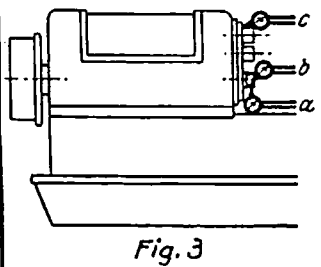

Fig. 3

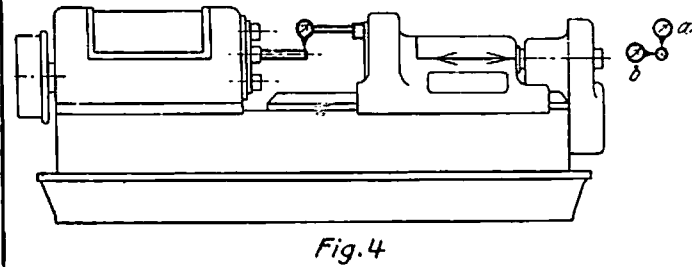

Fig. 4

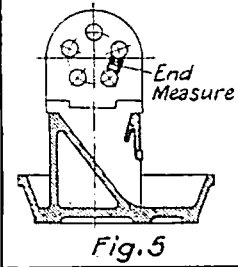

Fig. 5

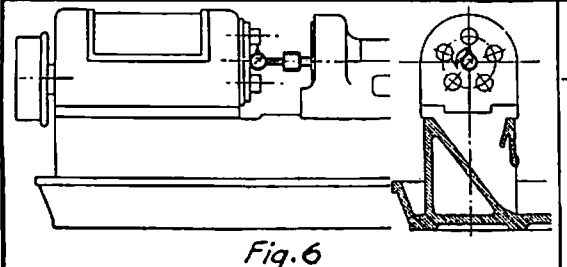

Fig. 6

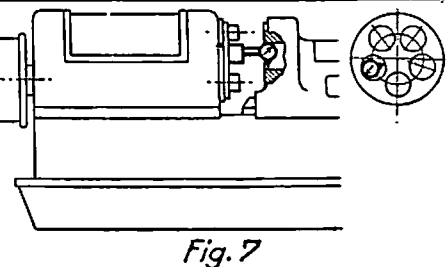

Fig. 7

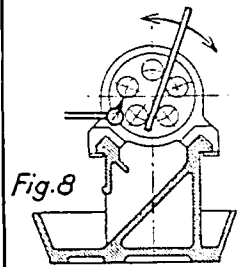
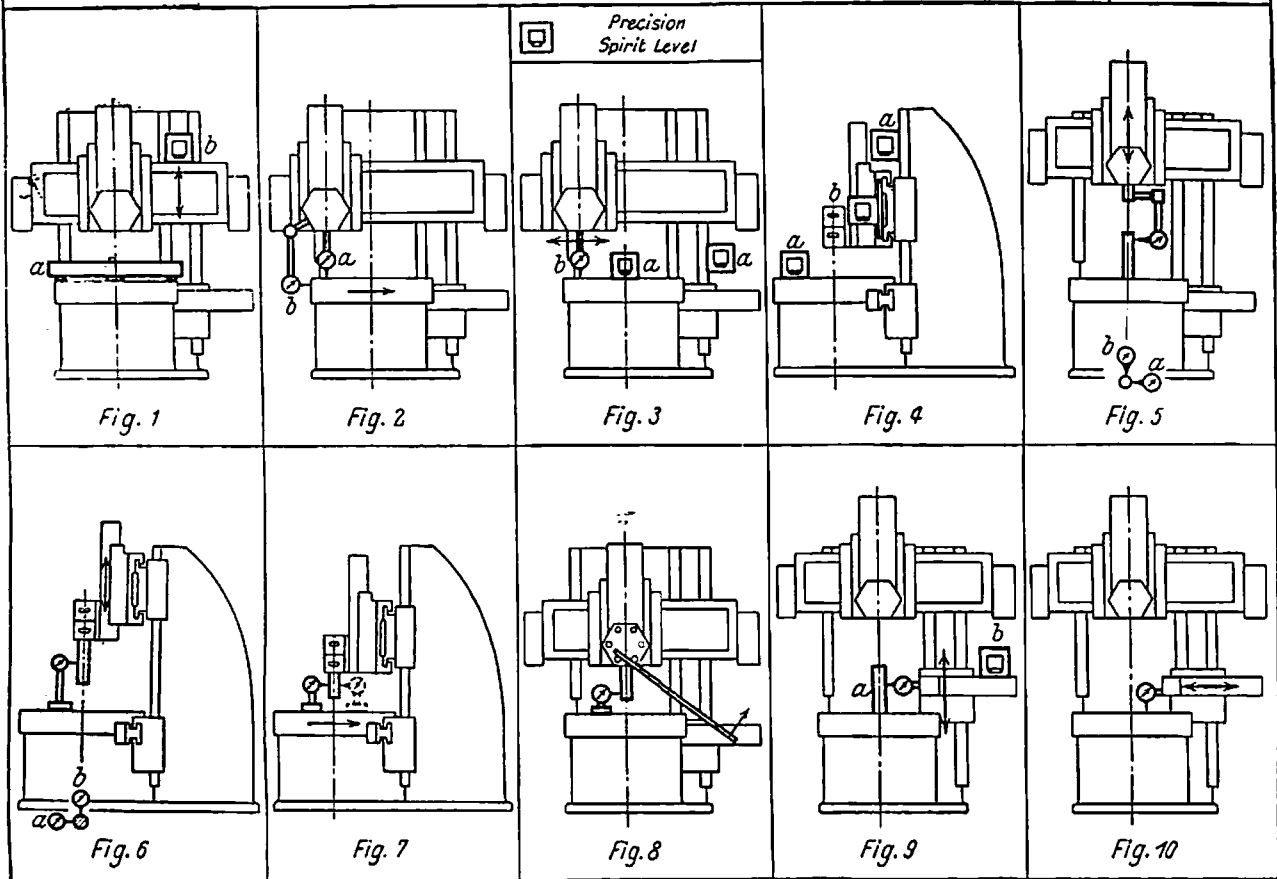

Fig. 8

Test Chart for Multi-spindle Automatics having Stationary Work and Rotary Tools		No. 18b Chart 3
Test to be Applied	Fig. No.	Permissible Error
		mm.
The sizes of diameters which are finished on the work pieces successively taken from the machine are uniform within the following allowances,* for machines		
		0.040
		0.045
Up to 50 mm. (about 2 in.) turning diameter		0.045
From 51 to 80 mm. (2 in. to about 3 1/8 in.) turning diameter		0.055
Over 80 mm. turning diameter		
* These allowances relate to the corresponding largest turning diameter on the total turning length, I.S.O. fit, quality 8.		

Test Chart for Vertical Boring Mills (Vertical Lathes)		No. 19 Chart 1
Test to be Applied	Fig. No.	Permissible Error
Faceplate level (concave only) .. ..	1a	mm. 0 to 0.02 per 1,000 mm. in diam.
Faceplate for true running .. ..	2a	0.03 per 1,000 mm. in diam.
Faceplate for true running .. ..	2b	0.03 per 1,000 mm. in diam.
Cross rail* and uprights:		
Upright square with faceplate in the guide plane of upright	3a	0.04 per 1,000 mm.
Ditto, in plane perpendicular to guide plane (upright at upper end inclined towards the front side only)	4a	0 to 0.04 per 1,000 mm.
Cross rail parallel with faceplate or table	3b	0.04 per 1,000 mm.
Front guide surface of cross rail, flat or level	4b	0.05 per 1,000 mm.
Incline of cross rail in its vertical adjustment	1b	±0.04 per 1,000 mm.
Turret head slide:		
Movement of head slide parallel with axis of table in the guide plane of upright (measured on aligned mandrel; swivel plate fixed by index pin)	5a	0.01 per 300 mm.
Ditto, in plane perpendicular to guide plane	5b	0.01 per 300 mm.
* The movement of the cross rail should be upwards. The turret slide should be in its middle position.		

For Table of Equivalents in English Measure see page 70



Test Chart for Vertical Boring Mills (Vertical Lathes)		No. 19 Chart 2
Test to be Applied	Fig. No.	Permissible Error mm.
Tool holes parallel with movement of head slide in guide plane of upright	6a	0.02 per 300 mm.
Ditto in plane perpendicular to guide plane	6b	0.02 per 300 mm.
Tool holes in line with axis of table	7	0.02
Turret head is free from play or clearance in its bearing and locking notches. Permissible amount of rotation about its axis, measured at the end of a mandrel 200 mm. (8 in.) long (length of lever arm about 0.5 m. (20 in.))	8	0.02
Side head: Vertical movement of side head parallel with axis of table (measured on aligned mandrel)	9a	0.01 per 300 mm.
Incline of side head in its vertical movement	9b	±0.02 per 1,000 mm.
Horizontal movement of side head parallel with table surface (turning concave only)	10	0 to 0.01 per 300 mm.
Working accuracy of machine is assured: Machine turns round with turret head tools:		
Turning diameter up to 800 mm. (about 31½ in.) within		0.01
Turning dia. over 800 mm. within		0.02
Ditto, with side head tools turning dia. up to 800 mm. (31½ in.) within		0.01
Over 800 mm. turning dia. within		0.02

Test Chart for Vertical Boring Mills (Vertical Lathes)		No. 19 Chart 3
Test to be Applied	Fig. No.	Permissible Error mm.
Machine turns cylindrically with turret head tools within		0.02 per 300 mm.
Ditto, with side head tools within		0.02 per 300 mm.
Machine faces with turret head tools (concave only) within		0 to 0.02 per 300 mm. in diam.
Ditto, with side head tools (concave only) within		0 to 0.02 per 300 mm. in diam.

For Table of Equivalents in English Measure see page 70

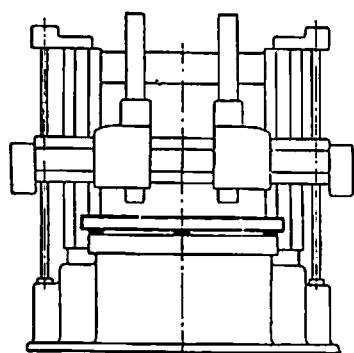

Fig. 1

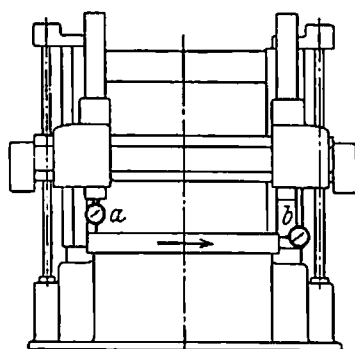

Fig. 2

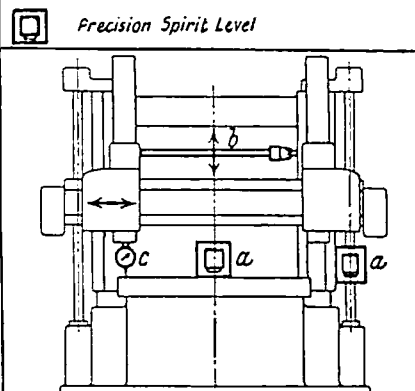

Fig. 3

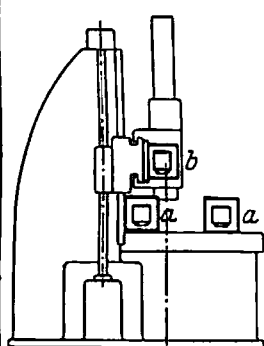

Fig. 4

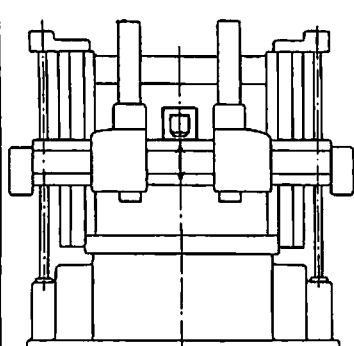

Fig. 5

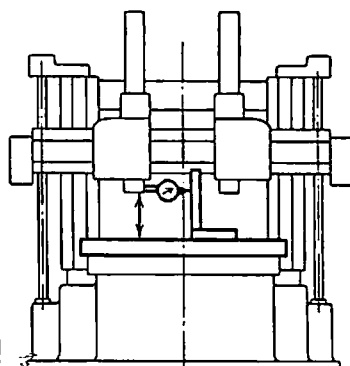

Fig. 6

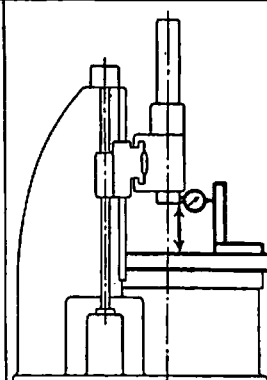

Fig. 7

Test Chart for Double-standard Vertical Turning and Boring Mills | No. 20 Chart 1

Test to be Applied	Fig. No.	Permissible Error
Faceplate or table: Table flat or level (concave only) ..	1	mm. 0 to 0.03 per 1,000 mm. in diam.
Face of the table for true running ..	2a	0.03 per 1,000 mm. in diam.
Table for true running .. .. .	2b	0.03 per 1,000 mm. in diam.
Standards and cross rail*: Standards square with table in guide plane of standards	3a	0.04 per 1,000 mm.
Ditto, in plane perpendicular to guide plane (inclined towards the front side at the upper end)	4a	0 to 0.04 per 1,000 mm.
Standards parallel with each other, measured on the inner or outer guide surfaces	3b	0.06 per 1,000 mm.
Cross rail parallel with table .. .	3c	0.05 per 1,000 mm.
Front guide surface of cross rail flat or level .	4b	0.05 per 1,000 mm.
Incline of cross rail in its vertical adjustment	5	±0.04 per 1,000 mm.

Test Chart for Double-standard Vertical Turning and Boring Mills | No. 20 Chart 2

Test to be Applied	Fig. No.	Permissible Error
Movement of ram parallel with table in guide plane of housing (swivel locked by index pin)	6	mm. 0.01 per 300 mm.
Ditto, in plane perpendicular to guide plane (movement at lower end inclined towards the housing)	7	0 to 0.01 per 300 mm.
Working accuracy of machine is assured: Machine turns round up to 3 m. (10 ft.) dia. within		0.02
Over 3 m. dia. within .. . . .		0.03
Machine turns cylindrically on a length of 300 mm. (about 12 in.) within		0.02
Machine turns cylindrically on a length of 1,000 mm. (about 40 in.) within		0.03
Machine faces (concave only) on 300 mm. dia. (about 12 in.) within		0 to 0.02
Machine faces (concave only) on 1,000 mm. dia (about 40 in.) within		0 to 0.03

\* The movement of the cross rail should be upwards against the weight. The tool holders should be in the mean position.

For Table of Equivalents in English Measure see page 70

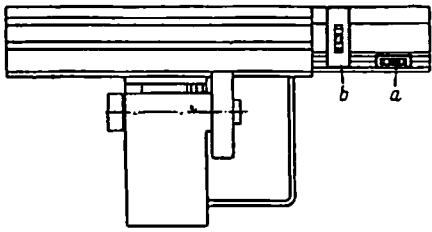

Fig 1

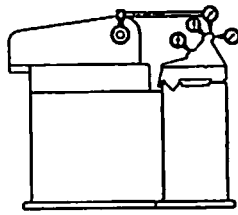

Fig 2

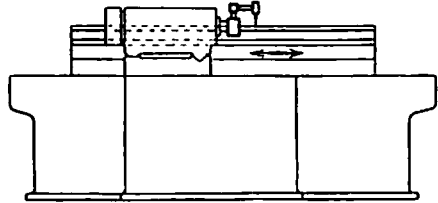

Fig 3

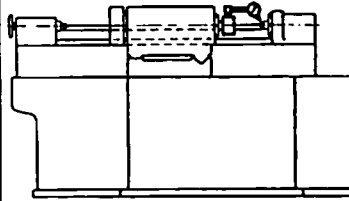

Fig 4

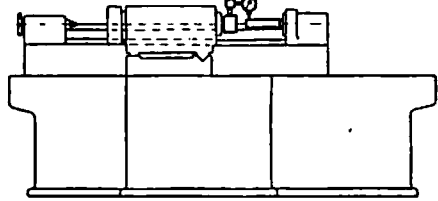

Fig 5

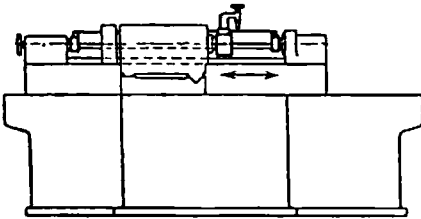

Fig 6

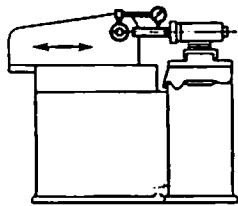

Fig 7

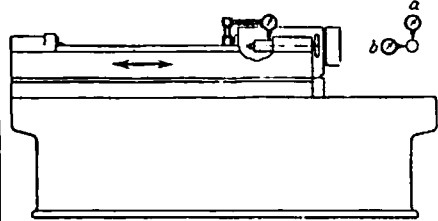

Fig 8

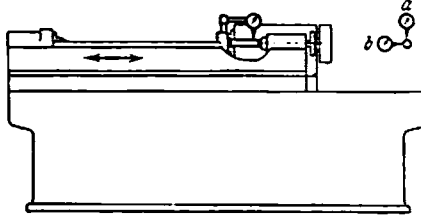

Fig 9

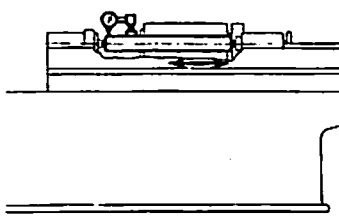

Fig 10

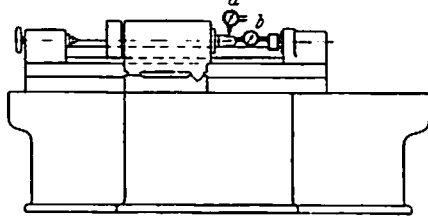

Fig 11

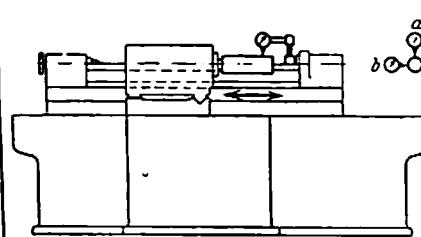

Fig 12

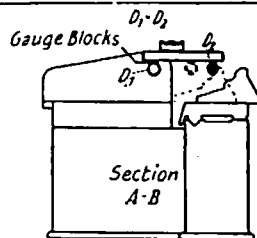

Fig 13

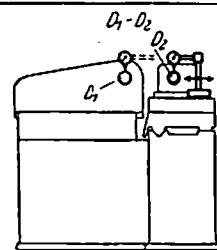

Fig 13a

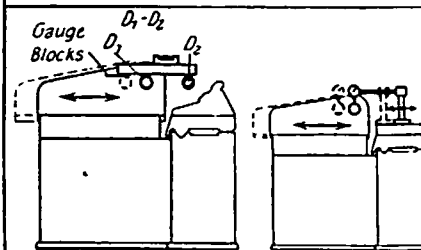

Fig 14

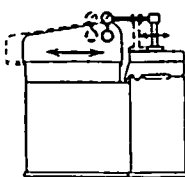

Fig 14a

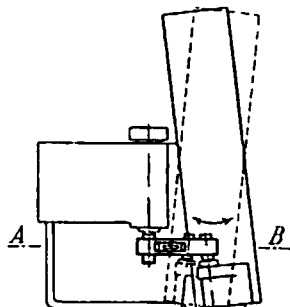
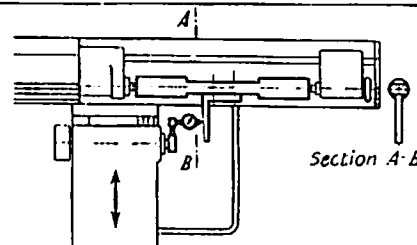

Fig 15



Section A-B

Test Chart for Cylindrical Grinding Machines		No. 21 Chart 1
Test to be Applied	Fig. No.	Permissible Error
		mm.
Bed and table: Bed straight in long. direction .. ..	1a	0.02 per 1,000 mm.
Bed flat or level in transverse direction. No twist permitted	1b	±0.02 per 1,000 mm.
Guide ways of headstock and tailstock parallel with table movement	2	0.01 per 1,000 mm.
Straightness of table movement (for machines of more than 2 m. (80 in.) in grinding length (grinding convex only))	3	0 to 0.02 per 1,000 mm.
Work headstock and spindle: Centre point for true running .. ..	4	0.005
Taper of work spindle runs true: (1) Nearest spindle nose .. .. (2) At a distance of 300 mm. (12 in.)	5	0.005 0.01
Axis of headstock parallel with table movement in vertical plane (rising towards the free end of mandrel; upper table in position of Fig. 2, zero position)	6a	0 to 0.02 per 300 mm.
Ditto, in horizontal plane (free end of mandrel inclined towards grinding wheel)	6b	0 to 0.01 per 300 mm.

Test Chart for Cylindrical Grinding Machines		No. 21 Chart 2
Test to be Applied	Fig. No.	Permissible Error
		mm.
Axis of spindle in swivelling headstock parallel with in-feed movement of grinding wheel slide in vertical plane, measured in the 90 and 45-degree positions of headstock (rising towards the free end of mandrel; for universal grinders only; the zero position is tested in conformance with Fig. 6a)	7	0 to 0.02 per 300 mm.
Tailstock: Sleeve parallel with table movement in vertical plane (front end rising only; upper table in position of Fig. 2) for long adjustment by hand	8a	0 to 0.02 per 100 mm.
Ditto, in horizontal plane (front end inclined towards the grinding wheel)	8b	0 to 0.01 per 100 mm.
Taper in sleeve parallel with table movement in vertical plane (free end on mandrel rising; upper table in position of Fig. 2)	9a	0 to 0.01 per 300 mm.
Ditto, in horizontal plane (free end of mandrel inclined towards the grinding wheel)	9b	0 to 0.01 per 300 mm.
Axis of centres (mandrel between centres) parallel with table movement in vertical plane (rising towards tailstock end)	10	0 to 0.01
Grinding wheel spindle: Taper of spindle for true running ..	11a	0.005
Spindle for axial slip measured at 2 points, displaced by 180°	11b	0.01

TABLE OF EQUIVALENTS			
1. For Converting Mm. Tolerances into Inch Tolerances			
Mm.	Inch	Mm.	Inch
0.003	0.00012	0.03	0.0012
0.005	0.0002	0.05	0.0020
0.01	0.0004	0.2	0.0080
0.02	0.0008		
2. Metric Reference Lengths into Inch Reference Lengths			
Mm.	Inch	Mm.	Inch
100	4	1,000	40
300	12		
3. Metric Tolerances Referred to Various Lengths into Inch Tolerances Referred to 1 Foot and 3 Feet			
Mm.	Inch per foot	Inch per 3 feet	
0.01 per 100 mm.	0.00120	0.00360	
0.01 " 300 "	0.00040	0.00120	
0.02 " 300 "	0.00080	0.00240	
0.01 " 1,000 "	0.00012	0.00036	
0.02 " 1,000 "	0.00024	0.00072	
0.03 " 1,000 "	0.00036	0.00108	
0.04 " 1,000 "	0.00048	0.00144	
0.05 " 1,000 "	0.00060	0.00180	
0.06 " 1,000 "	0.00072	0.00216	

Test Chart for Cylindrical Grinding Machines		No. 21 Chart 3
Axis of wheel spindle parallel with table movement in vertical plane (rising towards free end of mandrel)	12a	mm. 0 to 0.01 per 100 mm.
Ditto, in horizontal plane (free end of mandrel inclined towards the table)	12b	0 to 0.01 per 100 mm.
Axis of wheel spindle and headstock at same height with respect to swivel plate	13	0.1
Ditto, for internal grinding spindle	13a	0.02
Rise and fall of wheel spindle in its in-feed movement	14	0.05 on total length of in-feed motion
	14a	
In-feed motion of wheel slide square with bed ways (upper table set for cylindrical grinding by means of dial gauge)	15	0.01 on total length of in-feed motion
Quick approach to the work, repeats accurately to grinding position (6 repetitions)		0.003 mm.
Fine infeed: sensitive .. .. .		0.002 mm.
Working accuracy of machine: Machine grinds round Up to 80 mm. dia. (3 1/8 in.) .. From 80 to 200 mm. dia. (3 1/8-8 in.) Over 200 mm. dia. (8 in.) .. ..		0.003 0.005 0.01
Machine grinds cylindrically without applying steady rests (convex only): Shafts, 1,000 mm. long, 80 mm. dia. (about 40 by 3 1/8 in.) Shafts, 500 mm. long, 50 mm. dia. (about 20 by 2 in.) Shafts, 250 mm. long, 38 mm. dia. (about 10 by 1 1/2 in.)		0 to 0.015 0 to 0.008 0 to 0.005



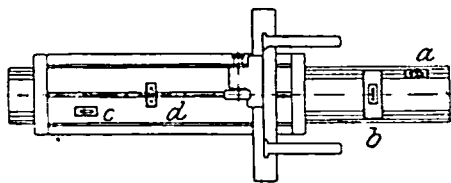

Fig. 1

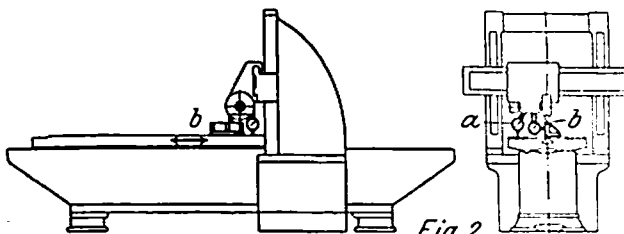

Fig. 2

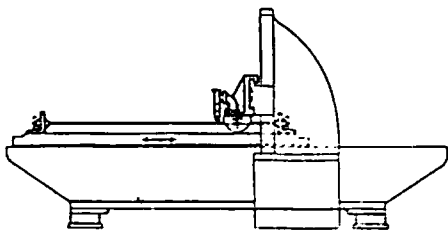

Fig. 3

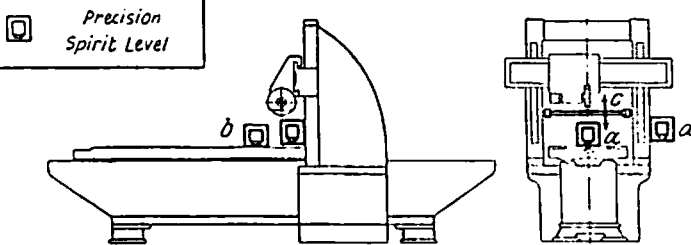

Fig. 4

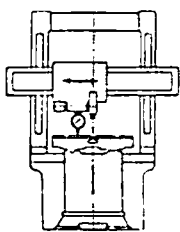

Fig. 5

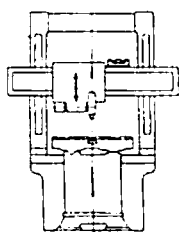

Fig. 6

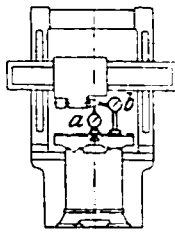

Fig. 7

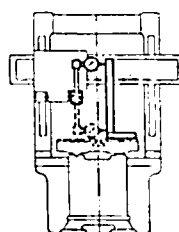

Fig. 8

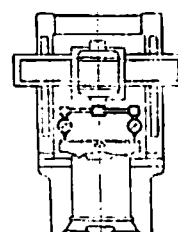

Fig. 9

Test Chart for Planer-type Surface Grinders		No. 22 Chart 1
Test to be Applied	Fig. No.	Permissible Error
Bed and table: Bed straight in long. direction .. ..	1a	mm. 0.02 per 1,000 mm.
Bed flat or level in transverse direction	1b	0.02 per 1,000 mm.
Table flat or level in long. direction ..	1c	0.02 per 1,000 mm.
Ditto, in transverse direction .. .. No twist permitted.	1d	±0.02 per 1,000 mm.
Rise and fall of table in its long. movement (for machines with horizontal wheel-spindle only)	2a	0.01 per 1,000 mm.
T-slots of table parallel with its long. movement (for machines with horizontal wheel-spindle only)	2b	0.01 per 1,000 mm.
Straightness of table movement (test made by using taut wire, straightedge or optical apparatus) (for machines with horizontal wheel-spindle only)	3	0.01 per 1,000 mm.

Test Chart for Planer-type Surface Grinders		No. 22 Chart 2
Test to be Applied	Fig. No.	Permissible Error
Standards and cross rail: Standards square with table in guide plane of standards	4a	mm. 0.02 per 1,000 mm.
Ditto in plane perpendicular to guide plane	4b	0.05 per 1,000 mm.
Standards parallel with each other, measured at inner or outer guide surfaces	4c	0.04 per 1,000 mm.
Cross rail parallel with table .. ..	5	0.02 per 1,000 mm.
Incline of cross rail in its vertical adjustment	6	±0.02 per 1,000 mm.
Grinding wheel saddle: Taper or centring sleeve of wheel spindle for true running	7a	0.01
Wheel spindle for axial slip .. ..	7b	0.01
Axis of wheel spindle parallel with table	8	0.01 per 300 mm.
Axis of wheel spindle square with table (for machines with vertical grinding wheel axis)	9	0.01 per 300 mm.
Working accuracy of machine: Ground work plane-parallel within ..		0.01 per 1,000 mm.

For Table of Equivalents in English Measure see page 70

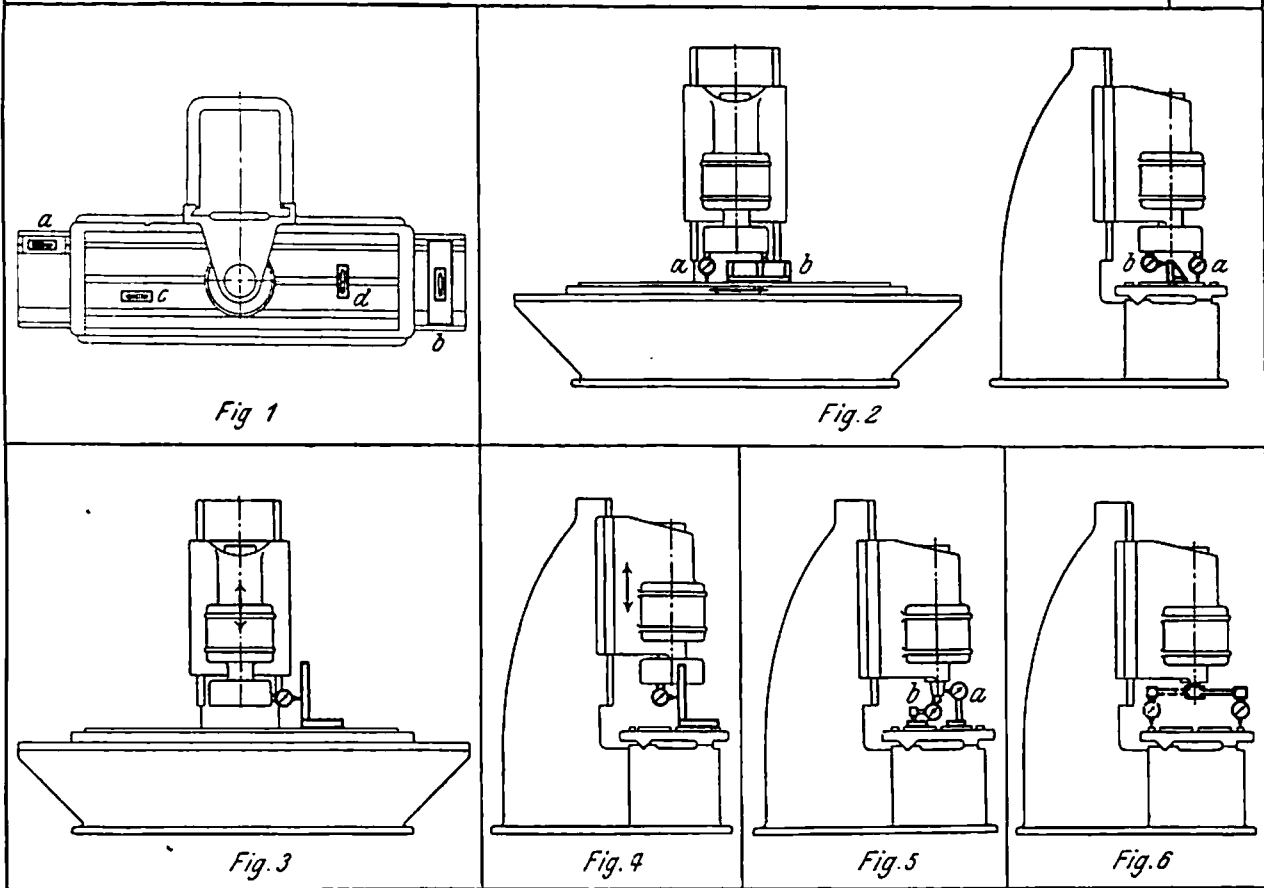

TABLE OF EQUIVALENTS

1. For Converting Mm. Tolerances into Inch Tolerances

Mm.	Inch	Mm.	Inch
0-01	0-0004	0-1	0-004
0-02	0-0008	—	—

2. Metric Reference Lengths into Inch Reference Lengths

Mm.	Inch	Mm.	Inch
100	4	1,000	40
300	12		

3. Metric Tolerances Referred to Various Lengths into Inch Tolerances Referred to 1 Foot and 3 Feet

Mm.	Inch per Foot	Inch per 3 Feet
0-01 per 100 mm.	0-00120	0-00360
0-02 " 100 "	0-00240	0-00720
0-03 " 100 "	0-00360	0-01080
0-01 " 300 "	0-00040	0-00120
0-02 " 300 "	0-00080	0-00240
0-03 " 300 "	0-00120	0-00360
0-01 " 1,000 "	0-00012	0-00036
0-015 " 1,000 "	0-00018	0-00054
0-02 " 1,000 "	0-00024	0-00072
0-03 " 1,000 "	0-00036	0-00108

Test Chart for Vertical Surface Grinders

No. 23

Test to be Applied	Fig. No.	Permissible Error
Bed and table: Bed straight in long. direction . . . . .	1a	mm. 0-02 per 1,000 mm.
Bed flat or level in transverse direction No twist permitted.	1b	±0-02 per 1,000 mm.
Table flat or level in long. direction . . .	1c	0-02 per 1,000 mm.
Ditto, in transverse direction . . . . .	1d	0-02 per 1,000 mm.
Rise and fall of table in its long. movement	2a	0-01 per 1,000 mm.
T-slots of table parallel with its long. movement	2b	0-02 on total length of table
Grinding wheel saddle: Guide ways of upright square with table surface in longitudinal direction	3	0-02 per 300 mm.
Ditto, in transverse direction . . . . .	4	0-02 per 300 mm.
Taper and centring sleeve, respectively, of wheel spindle for true running	5a	0-01
Wheel spindle for axial slip . . . . .	5b	0-005
Wheel spindle square with table in plane through centre of upright Radius of measuring arm 150 mm.	6	0-01 per 300 mm.
Working accuracy of machine: Ground work plane parallel to within . .		0-01 per 1,000 mm.

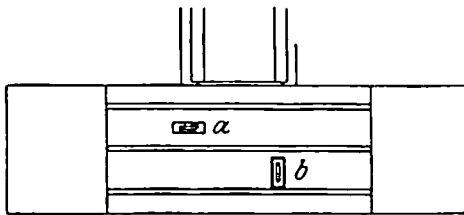

Fig. 1

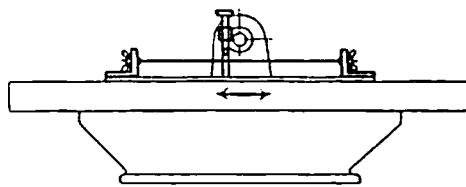

Fig. 4

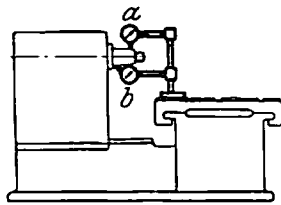
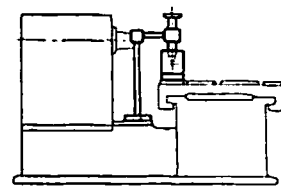

Fig. 2

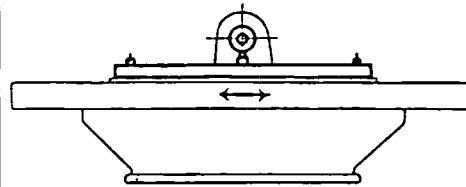

Fig. 4a

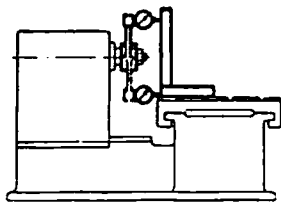
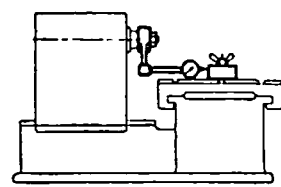

Fig. 3

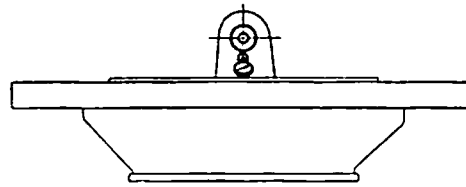
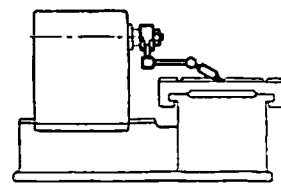
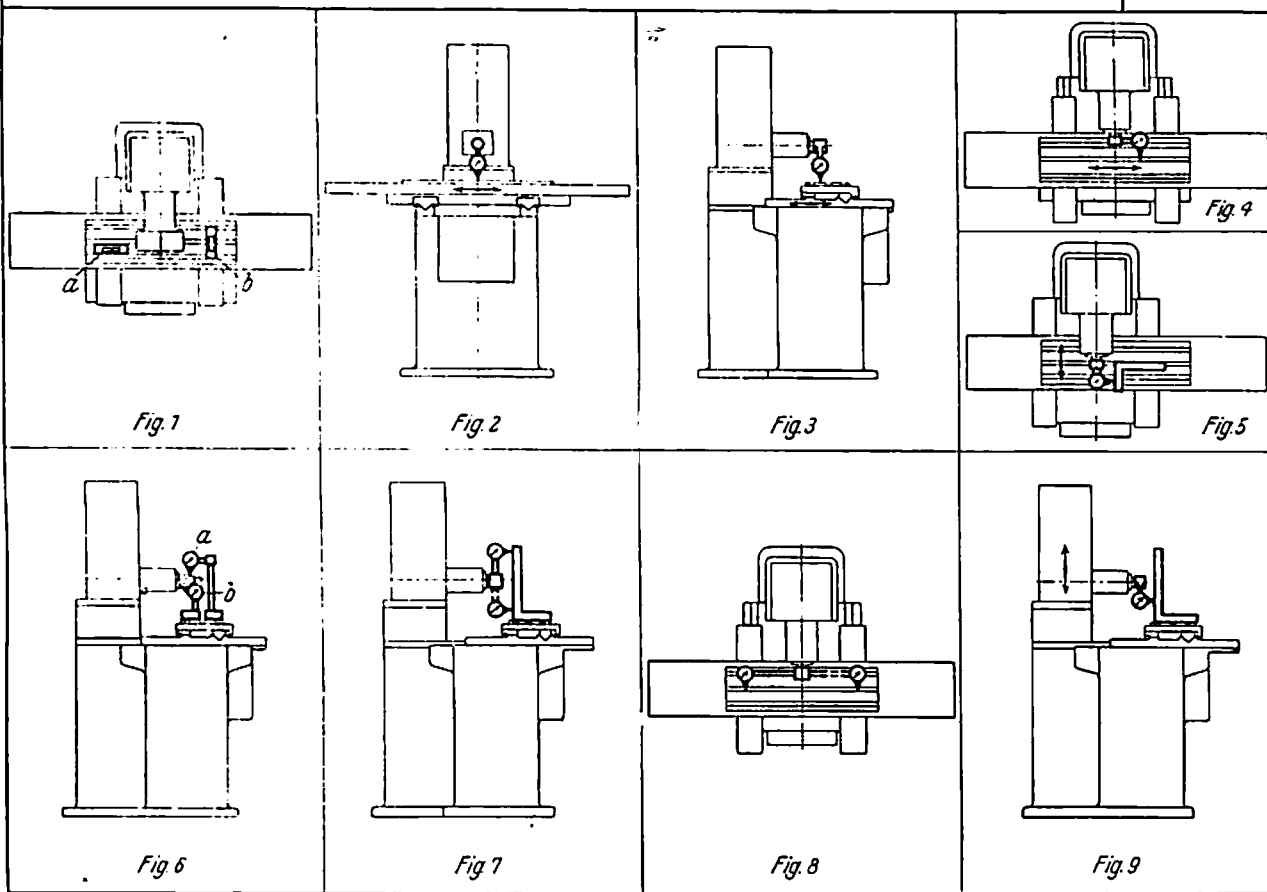

Fig. 5



Test Chart for Surface Grinders with Horizontal Wheel Axis		No. 24
Test to be Applied	Fig. No.	Permissible Error
Table flat or level in long. direction, measured at several positions of table	1a	mm. 0.02 per 1,000 mm.
Ditto, in transverse direction .. .. . No twist permitted.	1b	$\pm 0.02$ per 1,000 mm.
Taper and centring sleeve, respectively,* of wheel spindle for true running	2a	0.01
Wheel spindle for axial slip .. .. .	2b	0.01
Axis of wheel spindle parallel with surface of table .. .. .	3	0.01 per 300 mm.
Straightness of table movement ..	4	0.01 per 1,000 mm.
T-slots parallel with table movement ..	5	0.01 per 1,000 mm.
Working accuracy of machine: Machine grinds a flat plane surface, when finish grinding within .. .. When rough grinding, within .. ..		0.01 per 1,000 mm. 0.03 per 1,000 mm.
* For machines with pressed wheel-body, balanced together with main spindle.		



Test Chart for Surface Grinders with Vertically-adjustable Horizontal Grinding Wheel Spindles		No. 25 Chart 1
Test to be Applied	Fig. No.	Permissible Error
		mm.
Work table: Table flat or level in long. direction ..	1a	0.02 per 1,000 mm.
Ditto, in transverse direction .. .. .	1b	±0.02 per 1,000 mm.
Rise and fall, respectively, of table in its lengthwise movement	2	0.015 per 1,000 mm.
Surface of table parallel with its transverse movement	3	0.01 on total width of table
T-slots parallel with table movement ..	4	0.015 per 1,000 mm.
T-slots square with transverse movement of table	5	0.03 per 300 mm.
Wheel spindle: Taper and centring sleeve, respectively, of wheel spindle for true running	6a	0.01
Wheel spindle for axial slip .. .. .	6b	0.01
Wheel spindle parallel with table (test made by turn-round method)	7	0.02 per 300 mm.
Wheel spindle square with T-slots (tests made by turn-round method)	8	0.02 per 300 mm.

Test Chart for Surface Grinders with Vertically-adjustable Horizontal Grinding Wheel Spindles		No. 25 Chart 2
Test to be Applied	Fig. No.	Permissible Error
		mm.
Vertical adjustment of wheel spindle housing square with table in cross plane of machine	9	0.02 per 100 mm.
Working accuracy of machine: Machine grinds work plane parallel, when finishing within Machine grinds work plane parallel, when roughing		0.01 per 1,000 mm. 0.03 per 1,000 mm.

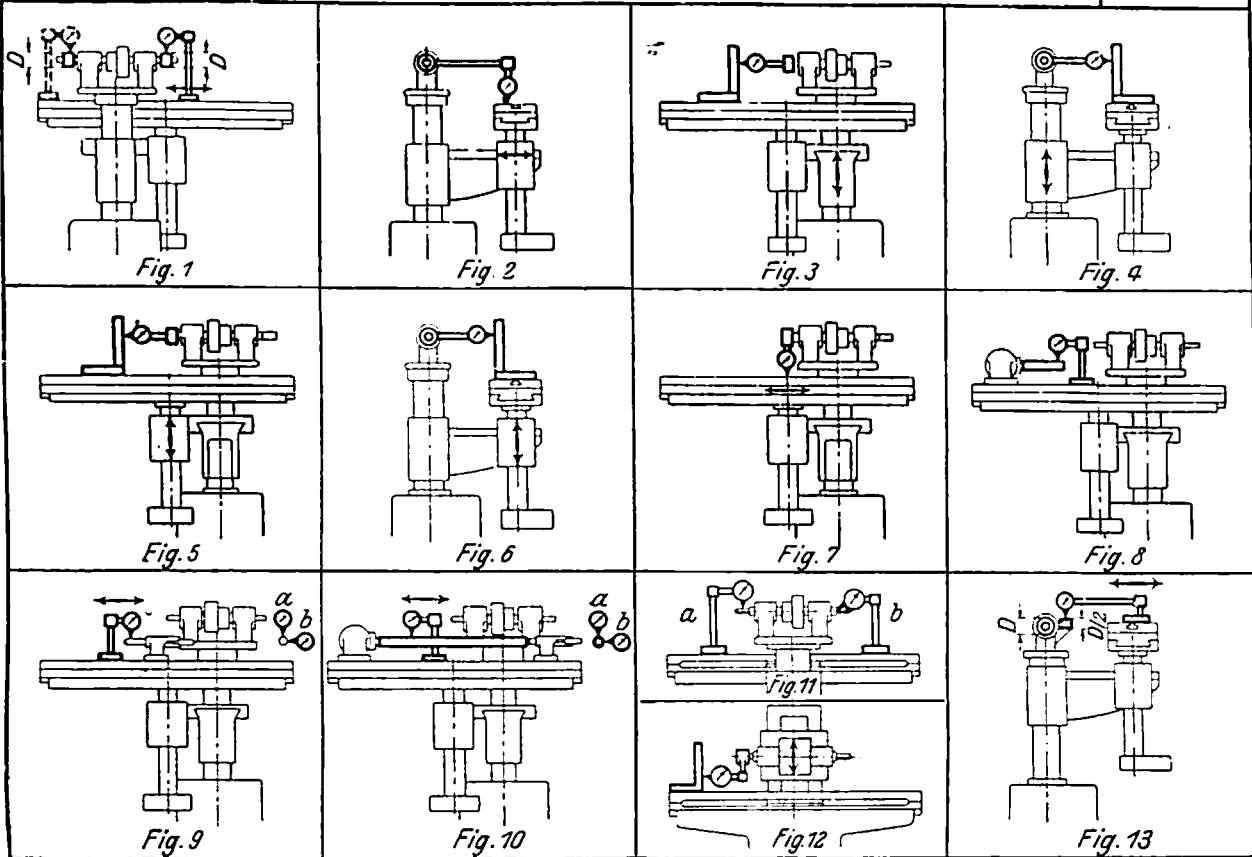

Test Chart for Universal Tool and Cutter Grinders		No. 26 Chart 1
Test to be Applied	Fig. No.	Permissible Error
mm.		
Work table: Table parallel with wheel spindle ..	1	0.02 per 300 mm.
Transverse movement of table parallel with table surface	2	0.01 per 100 mm.
Adjustment of knee square with table surface in plane through long. axis of table	3	0.03 per 100 mm.
Ditto, in plane perpendicular to said plane	4	0.03 per 100 mm.
Guide for pillar square with table in plane through longitudinal axis of table	5	0.03 per 100 mm.
Ditto, in plane perpendicular to said plane	6	0.03 per 100 mm.
Rise and fall, respectively, of table in its long. travel	7	0.03 per 300 mm.
Universal head and tailstock: Taper of work head spindle runs true; maximum amount by which mandrel 100 mm. long (about 4 in.) runs out of truth	8	0.01
Tailstock spindle parallel with table ..	9a	0.01 per 100 mm.

Test Chart for Universal Tool and Cutter Grinders		No. 26 Chart 2
Test to be Applied	Fig. No.	Permissible Error
mm.		
Tailstock spindle parallel with centre T-slot of table	9b	0.01 per 100 mm.
Tailstock axis in line with work head axis in vertical plane (work head previously to be set parallel with table and T-slot by means of mandrel)	10a	0.02
Ditto, in horizontal plane .. ..	10b	0.02
Wheel spindle:		
Wheel spindle for true running .. ..	11a	0.01
Wheel spindle for axial slip .. ..	11b	0.01
Vertical adjustment of wheel head square with work table in plane through long. axis of table (for machines with vertically adjustable wheel head)	12	0.03 per 100 mm.
Ditto, in plane perpendicular to said plane (for machines with vertically adjustable wheel head)	according to 12	0.03 per 100 mm.
Pad for centre gauge on level with axis of wheel spindle	13	0.1

For Table of Equivalents in English Measure see page 76

# Testing Upright Drilling Machines

31

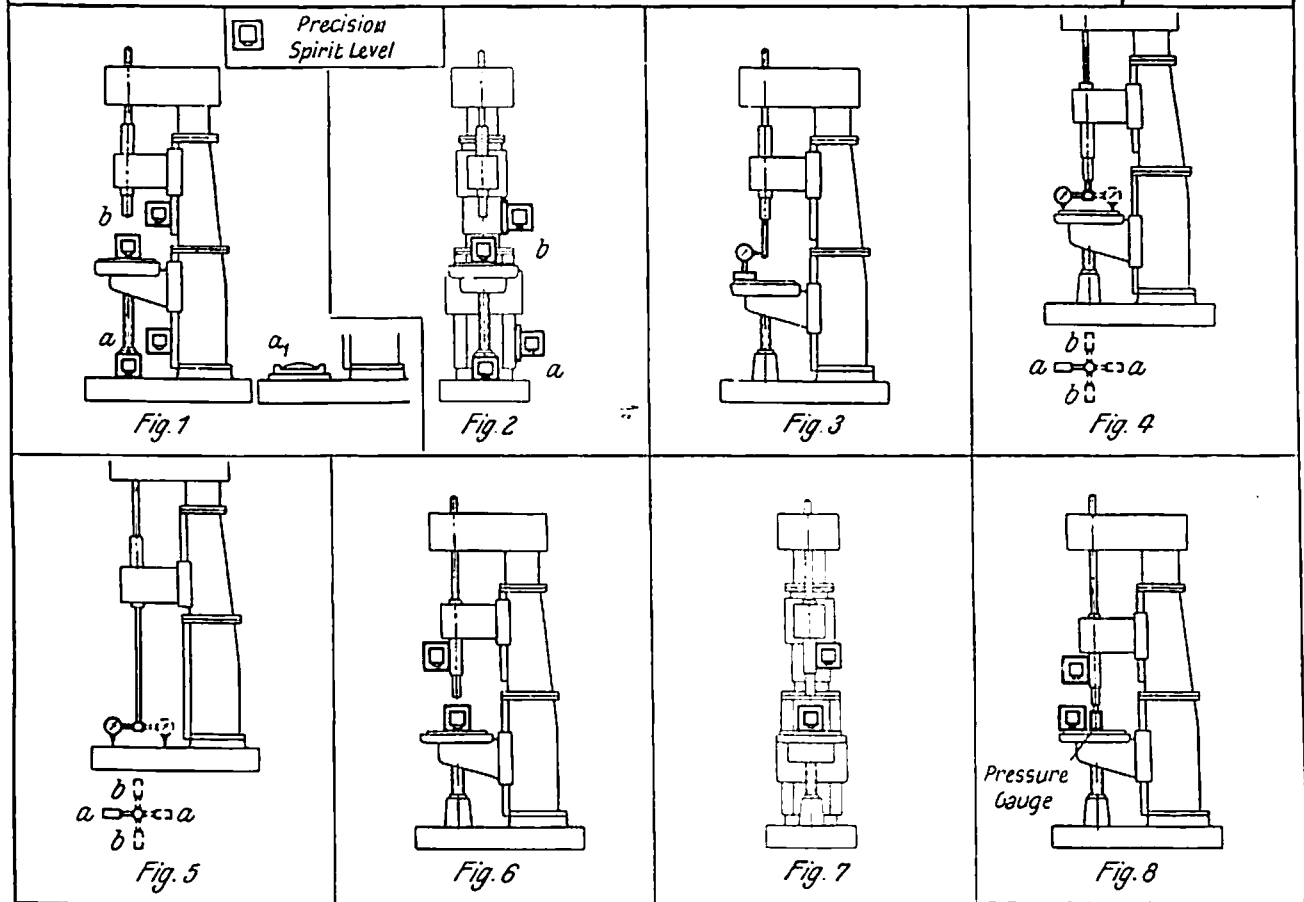

## TABLE OF EQUIVALENTS

1. For Converting Mm. Tolerances into Inch Tolerances			
Mm.	Inch	Mm.	Inch
0.02	0.0008	0.05	0.0020
0.03	0.0012		
2. Metric Reference Lengths into Inch Reference Lengths			
Mm.	Inches	Mm.	Inches
100	4	1,000	40
300	12		
3. Metric Tolerances Referred to 100, 300, and 1,000 Mm. into Inch Tolerances Referred to 1 Foot and 3 Feet			
Mm.	Inch per Foot	Inch per 3 Feet	
0.02 per 100 mm.	0.00240	0.00720	
0.03 " 100 "	0.00360	0.01080	
0.04 " 100 "	0.00480	0.01440	
0.07 " 100 "	0.00840	0.02520	
0.01 " 300 "	0.00040	0.00120	
0.03 " 300 "	0.00120	0.00360	
0.05 " 300 "	0.00200	0.00600	
0.06 " 300 "	0.00240	0.00720	
0.08 " 300 "	0.00320	0.00960	
0.1 " 300 "	0.00400	0.01200	
0.1 " 1,000 "	0.00120	0.00360	
0.2 " 1,000 "	0.00240	0.00720	
0.3 " 1,000 "	0.00360	0.01080	
1 " 1,000 "	0.01200	0.03600	
1.5 " 1,000 "	0.01800	0.05400	
2.5 " 1,000 "	0.03000	0.09000	

## Test Chart for Upright Drilling Machines (Rigid Type)

No. 31 Chart 1

Test to be Applied	Fig. No.	Permissible Error
Upright: Levelling by frame level <i>a</i> or by spirit level and straightedge <i>a</i> <sub>1</sub>	1a	mm. 0.04 per 300 mm.
Upright (guides of work table) square with baseplate in plane through centre of baseplate (upper end inclined towards the front side)	1a	0 to 0.05 per 300 mm.
Ditto, in plane perpendicular to said plane	2a	0.03 per 300 mm.
Guides of drill spindle head square with table in plane of drill spindle (upper end inclined towards front side)	1b	0 to 0.05 per 300 mm.
Ditto, in plane perpendicular to said plane	2b	0.03 per 300 mm.
Drill spindle and work table: Taper of drill spindle runs true; maximum amount by which mandrel 300 mm. (12 in.) long runs out of truth	3	0.03
Drill spindle square with work table in plane through centre of baseplate (turn round method*; spindle at lower end inclined towards upright)	4a	0 to 0.05 per 300 mm.
Ditto, in plane perpendicular to said plane	4b	0.03 per 300 mm.

\* Turn round radius 150 mm. (6 in.)

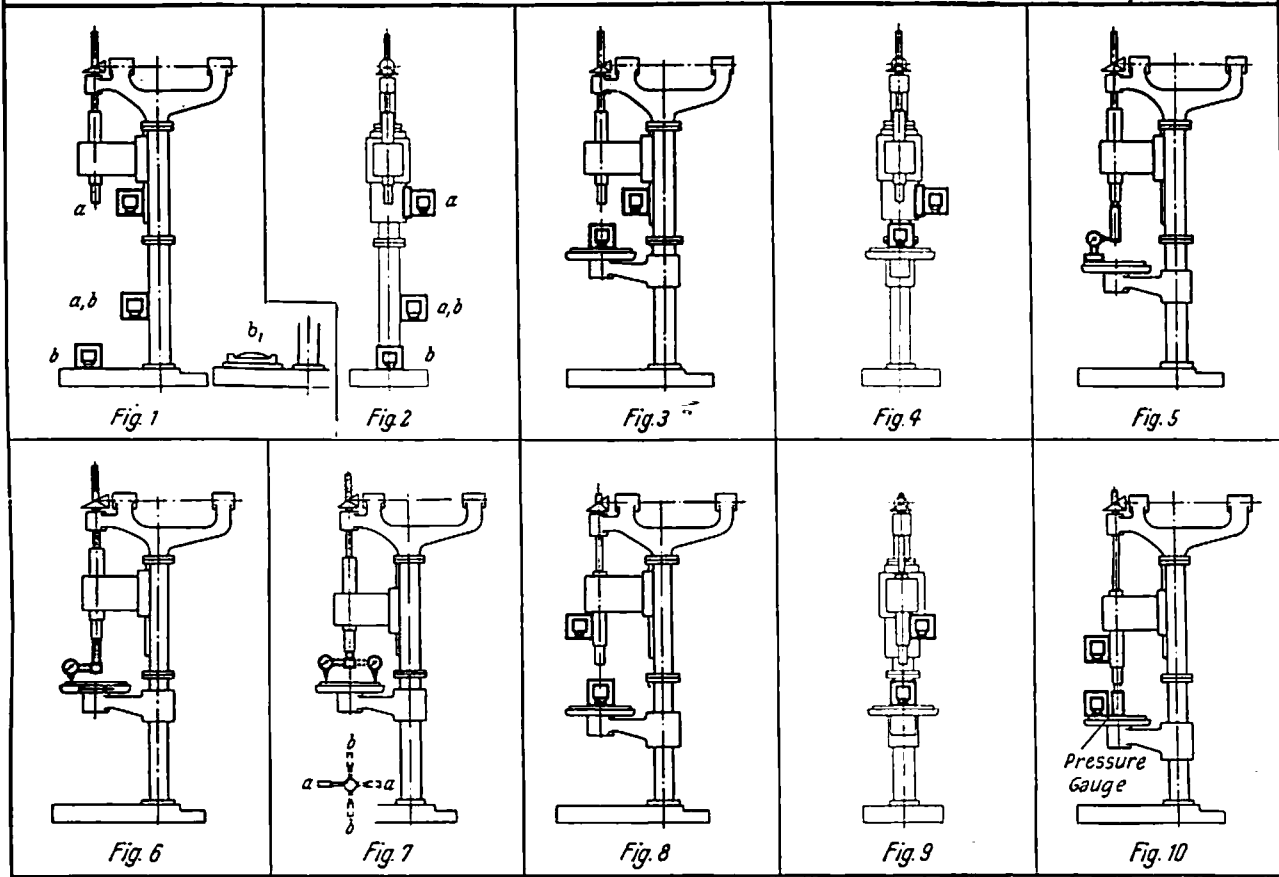

THE BRITISH DRILLING MACHINES CO. LTD.  
 MANUFACTURING DEPT.

Test Chart for Upright Drilling Machine (Rigid Type)		No. 31 Chart 2
Test to be Applied	Fig. No.	Permissible Error
Drill spindle square with baseplate in plane through centre of baseplate (turn-round method*; spindle at lower end inclined towards upright, sleeve in uppermost position)	5a	mm. 0 to 0.05 per 300 mm.
Ditto, in plane perpendicular to said plane	5b	0.03 per 300 mm.
Sleeve square with work table in plane of drill spindle (sleeve at lower end inclined towards upright; tests made with the counterweight supported)	6	0 to 0.05 per 300 mm.
Ditto, in plane perpendicular to said plane	7	0.03 per 300 mm.
Working accuracy of machine is assured: Maximum inclination of drill spindle from its position square with table, the drill pressure being set to correspond with the maximum diameter of drill and its proposed or advised feed, see table on page 22. (Drill spindle head and work table in positions half-way along their respective guide-ways)	8	1.0 per 1,000 mm.
* Turn round radius 150 mm. (6 in.)		

Test Chart for Pillar-Type Drilling Machines		No. 32 Chart 1
Test to be Applied	Fig. No.	Permissible Error
Column: Levelling by frame level <i>b</i> or by spirit level and straightedge <i>b<sub>1</sub></i> Drill head guides parallel with column (table guides) in plane through centre of base	1b 1a	mm. 0.04 per 300 mm. 0.05 per 300 mm.
Ditto, in plane perpendicular to said plane	2a	0.05 per 300 mm.
Column (table guides) square with baseplate in plane through centre of base (column inclined at upper end towards the front side)	1b	0 to 0.08 per 300 mm.
Ditto, in plane perpendicular to said plane	2b	0.05 per 300 mm.
Guides of drill head square with table in plane of drill spindle (guides inclined at upper end towards the front side)	3	0 to 0.08 per 300 mm.
Ditto, in plane perpendicular to said plane	4	0.05 per 300 mm.
Drill spindle and work table: Taper of drill spindle for true running: For machines with up to No. 2 Morse taper, measured on mandrel 100 mm. (4 in.) long Larger than No. 2 Morse tapers, measured on mandrel 300 mm. (12 in.) long	5	0.03 0.04

For Table of Equivalents in English Measure see page 76

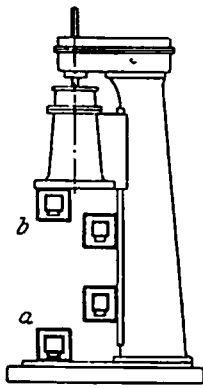

Fig. 1

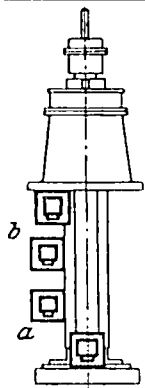

Fig. 2

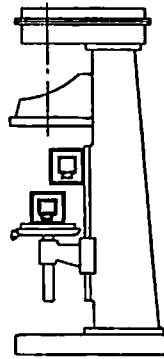

Fig. 3

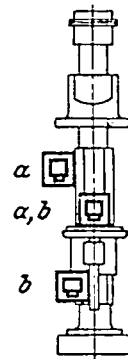

Fig. 4

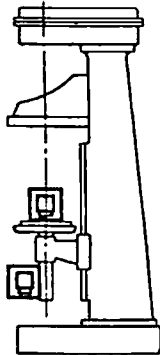

Fig. 5

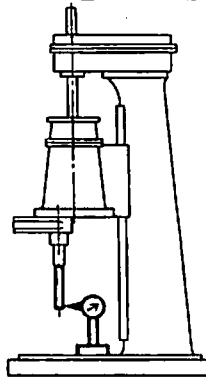

Fig. 6

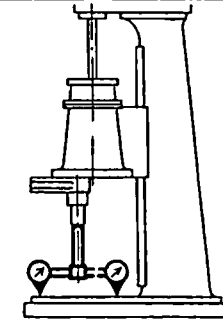

Fig. 7

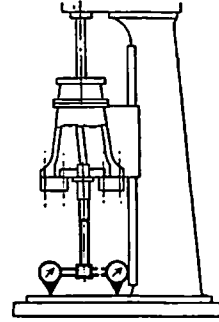

Fig. 8

Test Chart for Pillar Type Drilling Machines | No. 32 Chart 2

Test to be Applied	Fig. No.	Permissible Error
Work table for true running . . . .	6	mm. 0.05 per 300 mm. in diam.
Drill spindle square with table in plane through centre line of baseplate (measurements taken by the turn-round method; spindle inclined at lower end towards column)	7a	0 to 0.08 per 300 mm.
Ditto, in plane perpendicular to said plane	7b	0.05 per 300 mm.
Sleeve square with table in plane of drill spindle (sleeve inclined at lower end towards column; tests made with the counterweight supported)	8	0 to 0.06 per 300 mm.
Ditto, in plane perpendicular to said plane	9	0.06 per 300 mm.
Working accuracy of machine assured within: Maximum permissible incline of drill spindle from its position square with table, the drill pressure being set to correspond with the maximum diameter of drill at its recommended feed, see table on page 22. (Drill spindle head and work table in positions half-way along their respective guide ways)	10	2.5 per 1,000 mm.

Test Chart for Multi-spindle Drilling Machines with Universal-joint Driven Spindles | No. 33 Chart 1

Test to be Applied	Fig. No.	Permissible Error
Upright and spindle slide (for machines with adjustable spindle slide): Upright (guide ways for spindle slide) square with work clamping surface in plane through centre of machine	1a	mm. 0.05 per 300 mm.
Ditto, in plane perpendicular to said plane	2a	0.03 per 300 mm.
Bottom surface of spindle slide (clamping surface for spindle holders) square with upright guide ways in plane through centre of machine (dipping at front)	1b	0 to 0.06 per 300 mm.
Ditto, in plane perpendicular to said plane	2b	0.03 per 300 mm.
Upright and work table (for machines with adjustable work table): Work table square with guide ways of upright in plane through centre of machine (table rising at front end)	3	0 to 0.05 per 300 mm.
Ditto, in plane perpendicular to said plane	4a	0.03 per 300 mm.
Guide for table feed square with clamping surface of table in plane through centre of machine (table rising at front end)	5	0 to 0.04 per 100 mm.
Ditto, in plane perpendicular to said plane	4b	0.02 per 100 mm.

For Table of Equivalents in English Measure see page 76



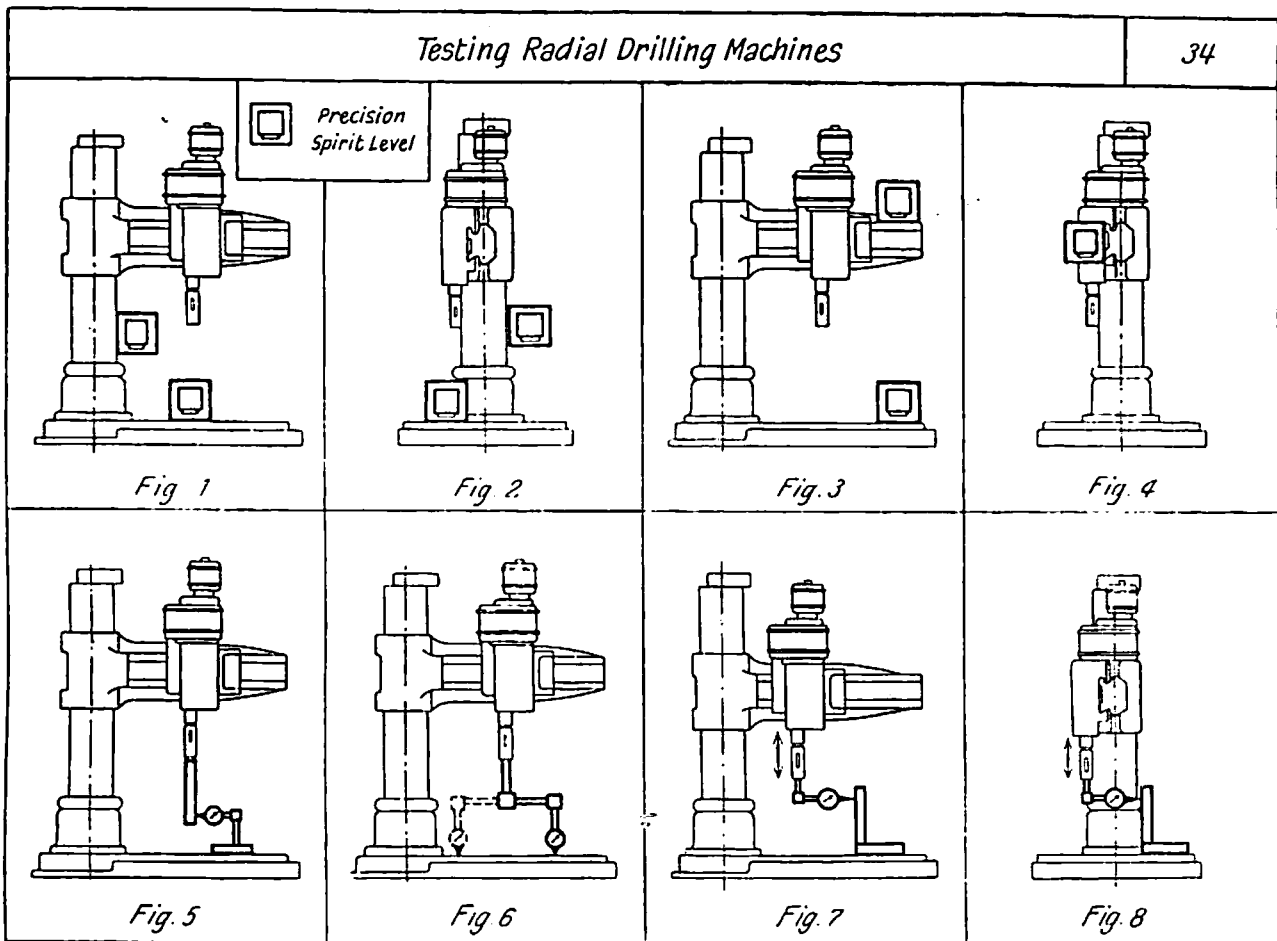

Test Chart for Multi-spindle Drilling Machines with Universal-joint Driven Spindles | No. 33 Chart 2

Test to be Applied	Fig. No.	Permissible Error
Drill spindles: Tapers of drill spindles for true running (measurements taken at an intermediate inclination of universal-joint spindles)	6	mm.
For machines with up to No. 2 Morse taper, measured on a mandrel, 100 mm. long (4 in.)		0.03
With Morse taper larger than 2, measured on a mandrel, 300 mm. long (12 in.)		0.05
Drill spindles square with clamping surface for work and work table, respectively, in plane through centre of machine (measurements taken by the turn-round method with the spindles set at an intermediate inclination; spindles inclined at lower end towards the upright):		
For universal-joint spindles mounted in adjustable spindle holders	7a	0 to 0.07 per 100 mm.
For universal-joint spindles mounted in fixed bearings on exchangeable cluster plate	8a	0 to 0.03 per 100 mm.
Ditto, in plane perpendicular to plane through centre of machine:		
For universal-joint spindles mounted in adjustable spindle holders	7b	0.07 per 100 mm.
For universal-joint spindles mounted in fixed bearings of exchangeable cluster plates	8b	0.03 per 100 mm.
Working accuracy: Parallelism of holes		0.1 per 100 mm.

Test Chart for Radial Drilling Machines | No. 34 Chart 1

Test to be Applied	Fig. No.	Permissible Error
Baseplate:*		mm.
Baseplate flat or level in longitudinal direction	1	0.1 per 1,000 mm.
Ditto, in transverse direction	2	0.1 per 1,000 mm.
Column:*		
Column square with baseplate in plane through centre line of baseplate (sleeve inclined towards the front side)	1	0 to 0.2 per 1,000 mm.
For machines up to 1,400 mm. (4 ft. 7 in.) length of radial arm (maximum spindle radius)		
For machines of over 1,400 mm. (4 ft. 7 in.) length of radial arm		0 to 0.3 per 1,000 mm.
Ditto, in plane perpendicular to plane through centre line of baseplate	2	0.1 per 1,000 mm.
Arm:*		
Arm parallel with baseplate (dipping at outer end):	3	0 to 0.2 per 1,000 mm.
For machines up to 1,400 mm. (4 ft. 7 in.) length of radial arm		
For machines of over 1,400 mm. length of radial arm		0 to 0.3 per 1,000 mm.
Saddle ways, flat or level	4	0.1 per 1,000 mm.
Drilling spindle:*		
Taper of spindle for true running; maximum amount by which mandrel 300 mm. (12 in.) long may run out	5	0.03
Spindle square with baseplate in plane through centre line of baseplate (lower end inclined towards column)	6**	0 to 0.2 per 1,000 mm.
Ditto, in plane perpendicular to said plane	6**	0.1 per 1,000 mm.

\* and \*\* See footnotes on Chart 2

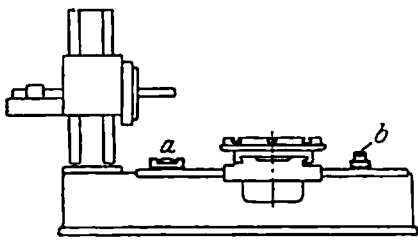

Fig. 1

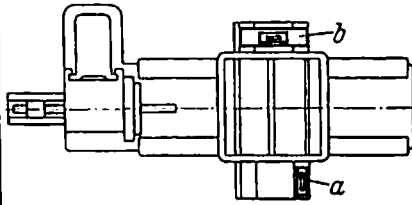

Fig. 2

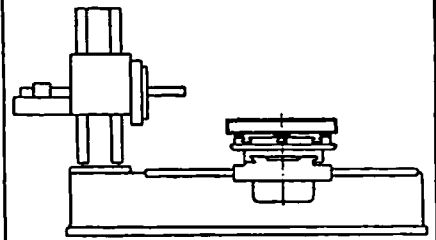

Fig. 3

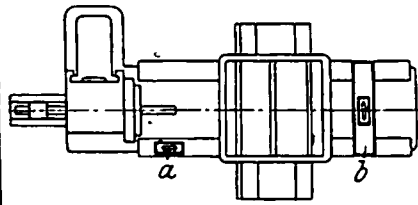

Fig. 4

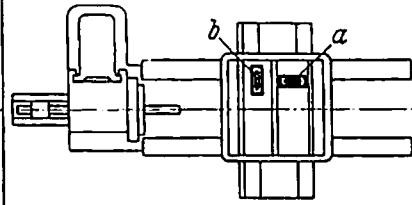

Fig. 5

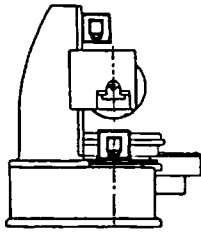
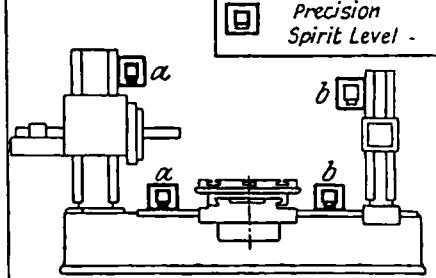

Fig. 6

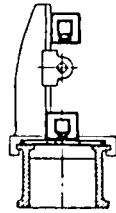

Fig. 7

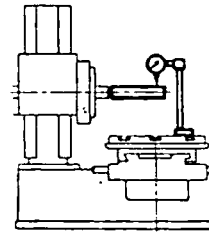

Fig. 8

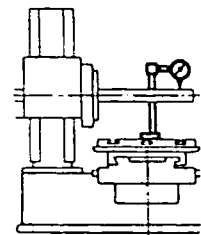

Fig. 9

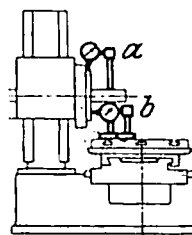

Fig. 10

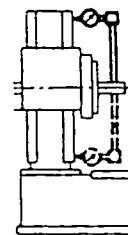

Fig. 11

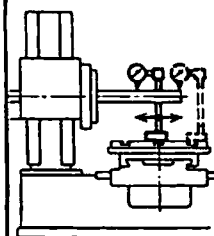

Fig. 12

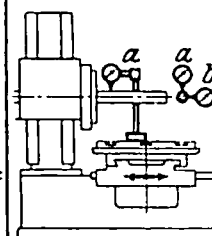

Fig. 13

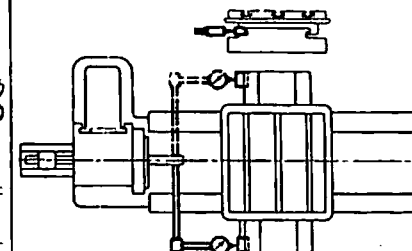

Fig. 14

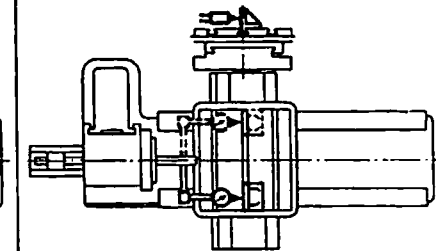

Fig. 15

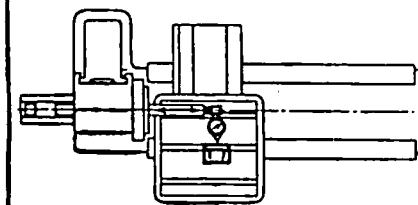

Fig. 16

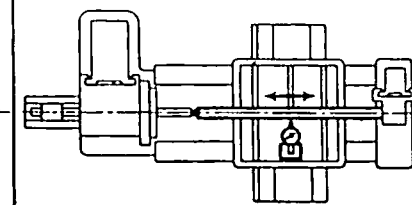

Fig. 17

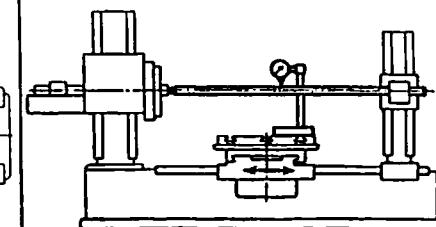

Fig. 18

Test Chart for Radial Drilling Machines		No. 34 Chart 2
Test to be Applied	Fig. No.	Permissible Error
Feed of spindle sleeve square with baseplate in plane through centre line of baseplate (inclined at lower end towards column) .. .. .	7	mm. 0 to 0.1 per 300 mm.
Ditto, in plane perpendicular to said plane	8	0.05 per 300 mm.
Drill spindle square with box table mounted on baseplate in plane through centre line of baseplate (spindle inclined at lower end towards column)	con- form- ing to 6	0 to 0.2 per 1,000 mm.
Ditto, in plane perpendicular to said plane	con- form- ing to 6	0.1 per 1,000 mm.
Working accuracy of machine is assured: Maximum permissible deflection of arm in the extreme position of saddle, when applying the maximum diameter of drill at the proposed feed according to table on page 22, provided that the baseplate is grouted in and bolted to the foundation (arm raised to half its vertical movement on the column) • With all measurements, the arm is to be positioned halfway up the column and the saddle halfway along the radial arm. •• Measurements taken in the following four positions: Radial arm raised to one-third and two-thirds of its vertical movement. Drilling-spindle axis in each case at approximately 300 mm. (12 in.) and two-thirds of radial arm length. Trammel arm 250 mm. (10 in.) long.		1.5 per 1,000 mm.

Test Chart for Horizontal Boring Machines with Spindles up to 80 mm. (3 1/8 in.) diameter		No. 35 Chart 1
Test to be Applied	Fig. No.	Permissible Error
Bed and work table: Bed ways straight in long. direction ..	1a	mm. ±0.01 per 1,000 mm.
Bed flat or level in transverse direction No twist permitted.	1b	±0.01 per 1,000 mm.
Ways of cross-slide straight in long. direction	2a	±0.01 per 1,000 mm.
Ways of cross slide flat or level in transverse direction	2b	±0.01 per 1,000 mm.
Work table flat or level (concave only) ..	3	0 to 0.03 per 500 mm.
Incline of table in its longitudinal travel	4a	±0.02 per 1,000 mm.
Ditto, in its transverse travel .. .. .	4b	±0.05 per 1,000 mm.
Ditto, in its rotary movement .. .. .	4	±0.02 per 1,000 mm.
Upright and outer support: Upright square with bed in plane of boring spindle (inclined at the upper end, inwards)	5a	0 to 0.03 per 1,000 mm.
Ditto, in plane perpendicular to said plane	6	±0.03 per 1,000 mm.

Test Chart for Horizontal Boring Machines with Spindles up to 80 mm. (3 1/8 in.) diameter		No. 35 Chart 2
Test to be Applied	Fig. No.	Permissible Error
Guides on outer support square with bed in plane of boring spindle	5b	mm. 0.05 per 1,000 mm.
Ditto, in plane perpendicular to said plane (incline corresponding with upright)	7	0.05 per 1,000 mm.
Spindle carriage: Taper of boring spindle runs true; maximum amount by which mandrel 300 mm. (12 in.) long may run out of truth (measurements taken with the spindle withdrawn)	8	near nose 0.01  0.02
Boring spindle for true running (spindle advanced by 300 mm. (12 in.))	9	0.03
Faceplate and spindle bush, respectively, for true running	10a	0.02
Faceplate and spindle bush, respectively, for axial slip; measured at 2 points, displaced by 180°	10b	0.01
Boring spindle square with ways on upright (spindle rising at front end)	11	0 to 0.03 per 1,000 mm.
Boring spindle parallel with work table in vertical plane	12	0.03 per 500 mm.

Test Chart for Horizontal Boring Machines with Spindles up to 80 mm. (3 1/8 in.) diameter		No. 35 Chart 3
Test to be Applied	Fig. No.	Permissible Error
Boring spindle parallel with travel of table in vertical plane	13a	mm. 0.02 per 500 mm.
Ditto, in horizontal plane .. .. .	13b	0.02 per 500 mm.
Boring spindle square with ways of cross slide (turn-round method) .. .. .	14	0.03 per 1,000 mm.
T-slots of table square with boring spindle in the zero position of table (locked by index pin)	15	0.02 per 500 mm.
T-slots of table parallel with feed of boring spindle in the 90° position of table (locked by index pin)	16	0.02 per 500 mm.
Bore of outer support in line with boring spindle in horizontal plane (lateral deflection; measured halfway up column)	17	0.03
Ditto, in vertical plane (automatic adjustment is made from the lower position upwards)	18	0.03
For the working accuracy of machine No. 35 see page 83.		

For Table of Equivalents in English Measure see page 76

Test Chart for Horizontal Boring Machines with Spindles over 80 mm. (3 1/8 in.) diameter		No. 36 Chart 1
Test to be Applied	Fig. No.	Permissible Error
Bed and work table: Bed ways straight in long. direction . .	1a	mm. ±0.02 per 1,000 mm.
Bed flat or level in transverse direction. No twist permitted.	1b	±0.02 per 1,000 mm.
Ways of cross slide straight in long. direction	2a	±0.04 per 1,000 mm.
Ways of cross slide flat or level in transverse direction	2b	±0.02 per 1,000 mm.
Work table flat or level (concave only) . .	3	0 to 0.03 per 500 mm.
Incline of work table in its long. travel	4a	±0.02 per 1,000 mm.
Ditto, in its transverse travel . . . .	4b	±0.05 per 1,000 mm.
Ditto, in its rotary motion . . . .	4	±0.02 per 1,000 mm.
Upright and outer support: Upright square with bed in plane of boring spindle (upright inclined inwards at upper end)	5a	0 to 0.03 per 1,000 mm.
Ditto, in plane perpendicular to said plane	6	±0.03 per 1,000 mm.
Guides of outer support square with bed in plane of boring spindle	5b	0.05 per 1,000 mm.
Ditto, in plane perpendicular to said plane (incline corresponding with upright)	7	0.05 per 1,000 mm.

Test Chart for Horizontal Boring Machines with Spindles over 80 mm. (3 1/8 in.) diameter		No. 36 Chart 2
Test to be Applied	Fig. No.	Permissible Error
Spindle carriage: Taper of boring spindle runs true: maximum amount by which mandrel 300 mm. (12 in.) long may run out of truth (measurements taken with spindle withdrawn)	8	mm. 0.02
Boring spindle for true running (spindle advanced by 500 mm. (20 in.))	9	0.03
Faceplate and spindle bush, respectively, for true running	10a	0.02
Faceplate and spindle bush, respectively, for axial slip; measured at two points, displaced by 180 deg.	10b	0.01
Boring spindle square with guide of upright (spindle rising)	11	0 to 0.03 per 1,000 mm.
Boring spindle parallel with work table in vertical plane	12	0.03 per 500 mm.
Boring spindle parallel with table movement in vertical plane	13a	0.02 per 500 mm.
Ditto, in horizontal plane . . . .	13b	0.02 per 500 mm.
Boring spindle square with ways of cross slide (turn-round method)	14	0.03 per 1,000 mm.
T-slots of table square with boring spindle in the zero-position of table (locked by means of index pin)	15	0.02 per 500 mm.
T-slots of table parallel with feed of boring spindle in the 90-deg. position of table (locked by index pin)	16	0.02 per 500 mm.
Bore of outer support in line with boring spindle in horizontal plane (lateral deflection; measured halfway up column)	17	0.03

Test Chart for Horizontal Boring Machines with Adjustable Columns		No. 37
Tests to be Applied	Fig. No.	Permissible Error
Bed and upright: Bed ways straight in long. direction . .	1a	mm. ±0.02 per 1,000 mm.
Bed flat or level in transverse direction. No twist permitted.	2a	±0.02 per 1,000 mm.
Guides of upright square with bed in plane of boring spindle	2b	0.03 per 1,000 mm.
Ditto, in plane perpendicular to said plane	1b	±0.03 per 1,000 mm.
Spindle carriage: Taper of boring spindle runs true; maximum amount by which mandrel 300 mm. (12 in.) long may run out of truth (measurements taken with the spindle withdrawn)	3	0.02
Boring spindle for true running Spindle advanced 500 mm. (20 in.)	4a	0.03
" " 1,000 " (40 " )		0.05
" " 1,500 " (60 " )		0.08
Faceplate and spindle bush, respectively, for true running	4b	0.02
Faceplate and spindle bush, respectively, for axial slip: measured at two points displaced by 180 deg.	4c	0.015
Boring spindle square with upright (turn-round method; spindle rising at front end)	5	0 to 0.03 per 1,000 mm.
Boring spindle square with bed (turn-round method)	6	±0.03 per 1,000 mm.

*Testing Horizontal Boring Machines with Adjustable Columns* 37

Precision Spirit Level

Working Accuracy Horizontal Boring Machine	Spindle up to 80 mm. (3 1/8 in.) No. 35 and 38	Spindle over 80 mm. (3 1/8 in.) No. 36	With adjustable column No. 37
	Permissible Error	Permissible Error	Permissible Error
The bores and outside diameters to be round	mm. 0-015	mm. 0-02	mm. 0-02
The bores to be cylindrical	0-02 per 300 mm.	0-04 per 300 mm.	0-04 per 300 mm.
In boring a hole half-way from one end and turning the revolving table through 180 deg. to complete the hole, the bores to be concentric within	0-015	0-025	0-025
Outside and inside diameters of test piece to be concentric within	0-025	0-04	0-04
Machined surface to be flat (concave only)	0 to 0-015 per 300 mm.	0 to 0-025 per 300 mm.	0 to 0-025 per 300 mm.
Milled surfaces on opposite sides of work to be parallel within	0-025 per 300 mm.	0-025 per 300 mm.	0-025 per 300 mm.
Surfaces at right angles to be square within	0-025 per 500 mm.	0-025 per 500 mm.	0-025 per 500 mm.

Test Chart for Horizontal Boring Machines   No. 38 with Fixed Headstocks up to 80 mm. (3 1/8 in.)   Chart 1		
Test to be Applied	Fig. No.	Permissible Error
Bed and work table: Guides for outer support square with guides of knee column	1a	mm. $\pm 0-01$ per 1,000 mm.
Guides for outer support parallel with guides of column in plane of boring spindle	1b	0-02 per 1,000 mm.
Ditto, in plane perpendicular to said plane	2	0-02 per 1,000 mm.
Guides of knee straight in long. direction	3a	$\pm 0-02$ per 1,000 mm.
Guides of knee flat or level in transverse direction	3b	$\pm 0-02$ per 1,000 mm.
Work table flat or level (concave only) . . .	1c	0 to 0-02 per 500 mm.
Incline of table in its vertical adjustment	3c	$\pm 0-03$ per 1,000 mm.
Ditto, in its longitudinal travel . . . . .	3c	$\pm 0-03$ per 1,000 mm.
Ditto, in its transverse travel . . . . .	3c	$\pm 0-03$ per 1,000 mm.
Ditto, in its rotary movement . . . . .	3c	$\pm 0-02$ per 1,000 mm.

*Testing Horizontal Boring Machines with Fixed Headstocks* 38

□ Precision Spirit Level

For Table of Equivalents in English Measure see page 76

Test Chart for Horizontal Boring Machines with Fixed Headstocks		No. 38 Chart 2
Test to be Applied	Fig. No.	Permissible Error
		mm.
Headstock: Taper of boring spindle runs true; maximum amount by which mandrel 300 mm. (12 in.) long may run out of truth (measurements taken with spindle withdrawn)	4	0.02
Boring spindle for true running (spindle advanced 500 mm. (20 in.))	5	0.03
Spindle bush for true running .. ..	6a	0.01
Spindle bush for axial slip .. ..	6b	0.01
Boring spindle parallel with table movement in horizontal plane .. ..	7	0.03 per 500 mm.
Boring spindle square with ways of cross slide (turn-round method)	8	0.03 per 1,000 mm.
T-slots of table square with boring spindle in the zero position of table (locked by index pin)	9	0.02 per 500 mm.
T-slots of table parallel with feed motion of boring spindle in 90-deg. position of table (locked by index pin)	10	0.02 per 500 mm.
Outer support bearing in line with boring spindle For working accuracy, see page 83.	11	0.02

Test Chart for Planing Machines (Double-standard Machines)		No. 41 Chart 1
Test to be Applied	Fig. No.	Permissible Error
		mm.
Bed and table: Bed straight in long. direction: Maximum deflection of spirit level ..	1a	$\pm 0.02$ per 1,000 mm.
Maximum rise of bed (for machines from 1.5 m.* (5 ft.) upwards in planing length; tests made by the water level and micrometer calipers method or by long straight edge and spirit level or by autocollimator)	2a	0.05
Bed flat or level in transverse direction: Maximum deflection of spirit level. No twist permitted Maximum rise (for machines from 2 m. (about 6 ft. 6 in.) upwards in planing length)	1b 2b	$\pm 0.02$ per 1,000 mm. 0.03
Table flat or level in longitudinal direction: Maximum deflection of spirit level ..	1c	$\pm 0.02$ per 1,000 mm.
Maximum rise (for machines from 3 m.* (10 ft.) upwards in planing length)	3a	0.05
* Measurement of rise by the methods noted is commenced at 1.5 m. (5 ft.) and 3 m. (10 ft.) respectively, since at, and beyond, these lengths the rise possible, if only measured by spirit level, begins to surpass the permissible error.		

### Testing Planing Machines

41

For Table of Equivalents in English Measure see page 76

Test Chart for Planing Machines (Double-standard Machines)		No. 41 Chart 2
Test to be Applied	Fig. No.	Permissible Error
Table flat or level in transverse direction; Maximum deflection of spirit level	1d	mm.
Maximum rise (for machines with from 2 m. (approximately 6 ft. 6 in.) planing width)	3b	$\pm 0.02$ per 1,000 mm. 0.03
Rise and fall, respectively, of table in its long. travel for machines Up to 2 m. planing length .. .. Over 2 m. planing length .. ..	4a	0.02 0.01 per 1,000 mm.
T-slots of table parallel with its long. travel for machines Up to 2 m. in planing length .. .. Over 2 m. in planing length .. ..	4b	0.02 0.01 per 1,000 mm.
Straightness of table movement (measure- ments taken by measuring wire and microscope) for machines Up to 2 m. planing length .. .. Over 2 m. planing length .. ..	5	0.02 0.01 per 1,000 mm.
Play between table rack and wheel ..		0.2
Uprights and cross rail: Uprights square with table in guide plane of uprights	6	0.03 per 1,000 mm.

Test Chart for Planing Machines (Double-standard Machines)		No. 41 Chart 3
Test to be Applied	Fig. No.	Permissible Error
Uprights parallel with each other, measured at the inner or outer surfaces of guide ways	7	mm. 0.04 per 1,000 mm.
Cross rail parallel with table For machines up to 2 m. (6 ft. 6 in.) planing width Over 2 m. planing width; for each additional 0.5 m. (20 in.) planing width the permissible error is to be increased by 0.01 mm (0.0004 in.).	8	0.03
Incline of cross rail in its vertical adjustment	9	$\pm 0.03$ per 1,000 mm.
Side head: Movement of side head square with table	10	0.02 per 500 mm.
Working accuracy of machine (if cutting tests are not possible): (Tests to be performed with a plane- parallel straight-edge representing a workpiece, unclamped and free from stresses): Work is finished parallel .. .. On machines up to 2 m. (80 in.) planing length within .. .. On machines with planing length over 2 m. (80 in.) within .. .. (Cutting tests, see upper right corner)	11	0.02 0.01 per 1,000 mm.

Working Accuracy of Planing Machines (Double-standard and Opside Planers)		Fig. No.	Permissible Error
I. Finishing 4 to 6 test blocks lengthwise Width and height of pieces (A, B, C, D, E, F): 75 mm. (3 in.); length of pieces, 500 mm. (20 in.) (1) Machines up to 2,000 mm. (6ft. 6in.) planing length use 4 test blocks (A, B, C, D) (2) Machines over 2,000 mm. (6ft. 6in.) planing length use 6 test-block (A, B, C, D, E, F). Error for each additional 1 m. (40 in.) in length Maximum permissible error .. .. Use Micrometers or microgauges 0.002 mm. accuracy Surfaces of pieces which rest on table must be carefully prepared. The pieces are fastened in the two outer T-slots of the table as indicated Heights of all points of the finished surface are checked from its base, using an accurate straight- edge as basic surface		12 13	0.02 mm. 0.01 mm. 0.05 mm.
II. Finishing two angle plates feeding the tool vertically downwards (1) Vertical surfaces of both angle plates aligned horizontally .. .. (2) Each angle plate vertical to table top Clock indicator (a), long straight- edge (b) The finished vertical surfaces of the angle plates (A <sub>1</sub> , A <sub>2</sub> ) are in the same plane. Square (B) on table The finished vertical surfaces of the angle plates are perpendic- ular to their bases The angle plates (A <sub>1</sub> , A <sub>2</sub> ) are fast- ened in the T-slot on the border of the table as far apart from each other as possible for all lengths		14	0.04 per 1,000 mm. 0.08 per 1,000 mm.

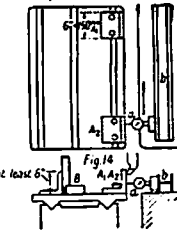
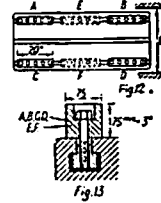

Test Chart for Opside Planing Machines		No. 42 Chart 1
Test to be Applied	Fig. No.	Permissible Error
Bed and planer table (see p. 86): Bed straight in long. direction: Maximum deflection of spirit level .. Maximum rise (for machines with planing lengths from 1.5 m.* (5 ft.) upwards; test made by the water level and micrometer calipers method or by long straight-edge and spirit level)	1a 2a	mm. $\pm 0.02$ per 1,000 mm. 0.05
Bed flat or level, in transverse direction: Maximum deflection of spirit level. No twist permitted Maximum rise for machines with planing width from 2 m. (about 6 ft. 6 in.) upward	1b 2b	$\pm 0.02$ per 1,000 mm. 0.03 2
Table flat or level in long. direction: Maximum deflection of spirit level Maximum rise (for machines with planing lengths from 3 m.* (10 ft.) upwards)	1c 3a	$\pm 0.0$ per 1,000 mm. 0.05
* Measurement of rise by the methods noted is commenced at 1.5 m. (5 ft.) and 3 m. (10 ft.) respectively, since at, and beyond, these lengths the rise possible, if only measured by spirit level, begins to surpass the permissible error.		

## Testing Openside Planing Machines

42

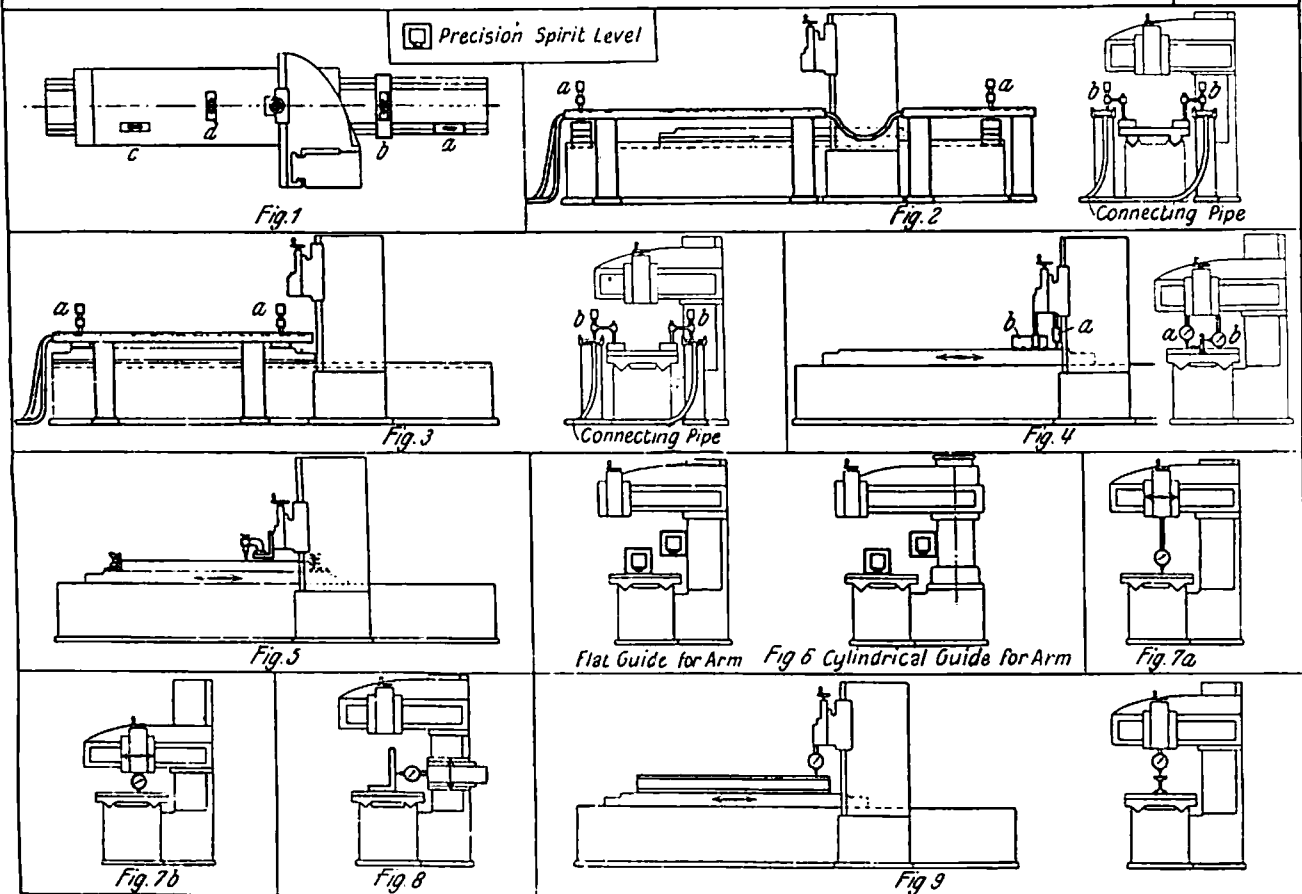

Test Chart for Openside Planing Machines			No. 42 Chart 2
Test to be Applied	Fig. No.	Permissible Error	
Table flat or level in transverse direction; Maximum deflection of spirit level	1d	mm. ±0.02 per 1,000 mm.	
Table flat or level in transverse direction: Maximum rise (for machines with planing widths of from 2 m. (approximately, 6 ft. 6 in.) upwards)	3b	0.03	
Rise and fall of table in its long. movement For machines up to 2 m. planing length Over 2 m. planing length .. ..	4a	0.02 0.01 per 1,000 mm.	
T-slots of table parallel with its long. movement for machines Up to 2 m. planing length .. .. Over 2 m. planing length .. ..	4b	0.02 0.01 per 1,000 mm.	
Straightness of table movement (tests made by measuring wire and microscope) For machines up to 2 m. planing length Over 2 m. planing length .. ..	5	0.02 0.01 per 1,000 mm.	
Play between table rack and wheel ..	..	0.02	

Test Chart for Openside Planing Machines			No. 42 Chart 3
Test to be Applied	Fig. No.	Permissible Error	
Column and arm: Column square with table in cross plane of machine (column inclined at upper end towards the table; cross rail in uppermost position, one tool box at end of arm while testing)	6	mm. 0 to 0.03 per 1,000 mm.	
Cross rail parallel with table (dipping at outer end; measurements to be made in extreme vertical positions of arm) For machines up to 2 m. (6 ft. 6 in.) planing width Over 2 m. planing width; for each additional 0.5 m. the permissible error is to be increased by 0.01 mm. (0.0004 in.)	7	0 to 0.03	
Side head: Vertical movement of side head square with table (inclined at upper end towards the table)	8	0 to 0.02 per 500 mm.	
Working accuracy of machine: (Tests made by parallel straight-edge representing a workpiece unclamped and free from stresses): The workpiece is finished parallel On machines up to 2 m. planing length within .. .. Over 2 m. planing length within ..	9	0.02  0.01 per 1,000 mm.	

For Table of Equivalents in English Measure see page 76



# Testing Shaping Machines

43

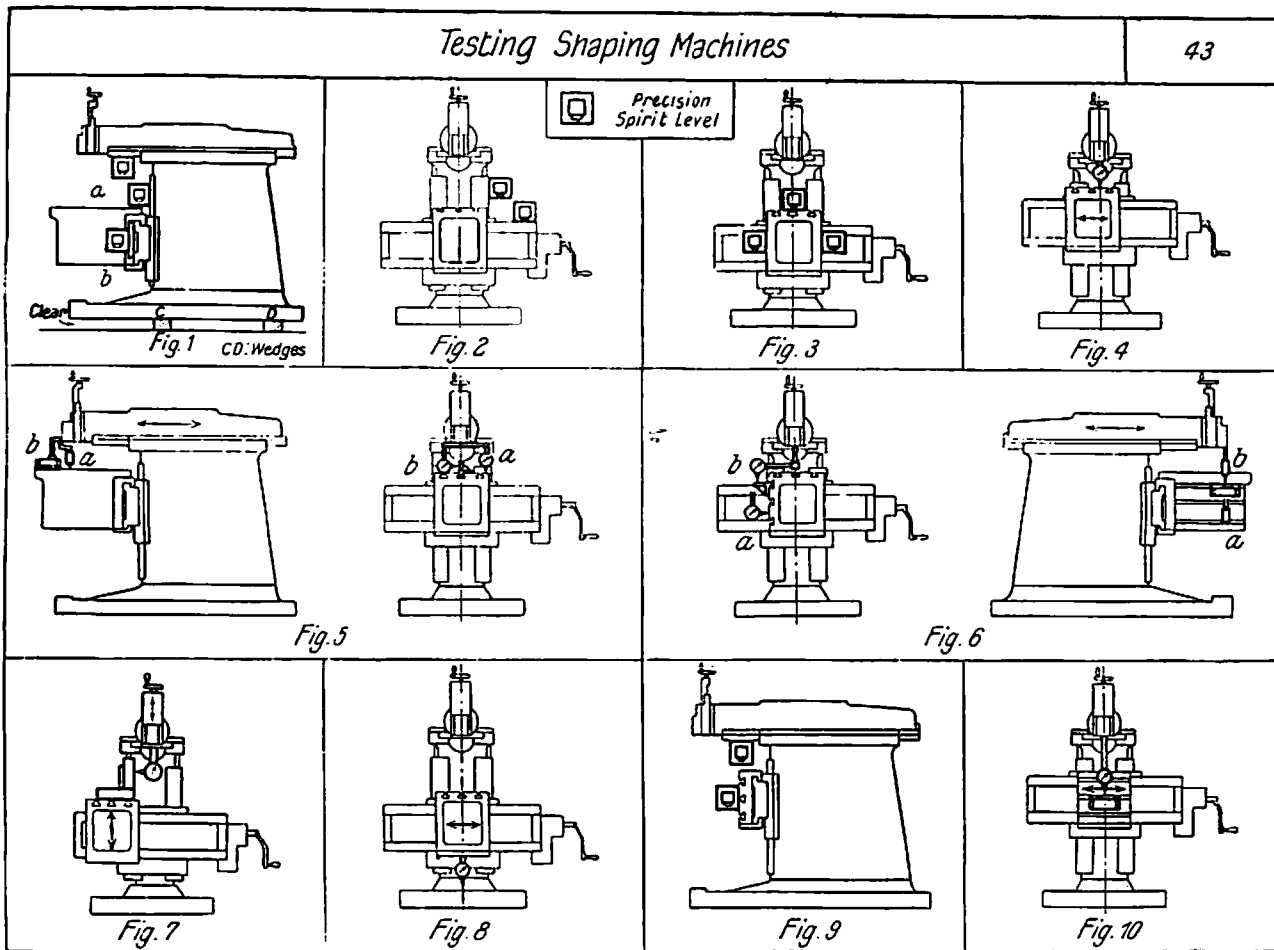

Test Chart for Shaping Machines		No. 43 Chart 1
Test to be Applied	Fig. No.	Permissible Error
Table flat and level in both directions . .	1	mm. 0.04 per 1,000 mm.
Column and table slide: Guide surface of ram square with guide surfaces of column in plane through centre of column	1a	0.02 per 300 mm.
Front bearing surface of table slide flat or level	1b	0.03 per 1,000 mm.
Upper guide on table slide square with column ways	2	0.03 per 300 mm.
Work table: Upper surface of table square with side clamping surfaces	3	0.02 per 300 mm.
Incline of table in its transverse move- ment	3	$\pm 0.015$ per 300 mm.
Ditto, in its vertical movement . . . .	3	$\pm 0.02$ per 300 mm.
Upper surface of table parallel with its transverse movement . . . .	4	0.01 per 300 mm.
Movement of ram parallel with work table (table rising at front) . . . .	5a	0 to 0.015 per 300 mm.
Movement of ram parallel with T-slots . .	5b	0.015 per 300 mm.
Movement of ram parallel with side clamping surfaces	6a	0.02 per 300 mm.

Test Chart for Shaping Machines		No. 43 Chart 2
Test to be Applied	Fig. No.	Permissible Error
Movement of ram parallel with side T-slots (slots rising at front end)	6b	mm. 0 to 0.02 per 300 mm.
Side clamping surfaces of table parallel with its vertical adjustment	7	0.02 per 300 mm.
Guide for table support parallel with transverse movement of table	8	0.02 per 300 mm.
Table saddle: (for machines equipped with saddle): Saddle surface square with guide surface of ram (inclined at upper end towards the column)	9	0 to 0.02 per 300 mm.
T-slots of table saddle parallel with its transverse movement	10	0.02 per 300 mm.
Working accuracy of machine: I. Finishing test-block: Maximum length 1. of test-block = $\frac{1}{3}$ of stroke of ram; 4 in. to 5 in. wide. Material: steel of 35 to 40 tons per sq. in. or cast-iron of 12 to 15 tons per sq. in. (1) Finishing surface A (2) Finishing surface B The finished surfaces are parallel with each other measured by micrometer of 0.002 mm. (0.0001 in.) accuracy	11	0.02 per 300 mm.

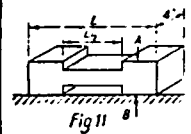

For Table of Equivalents in English Measure see page 76

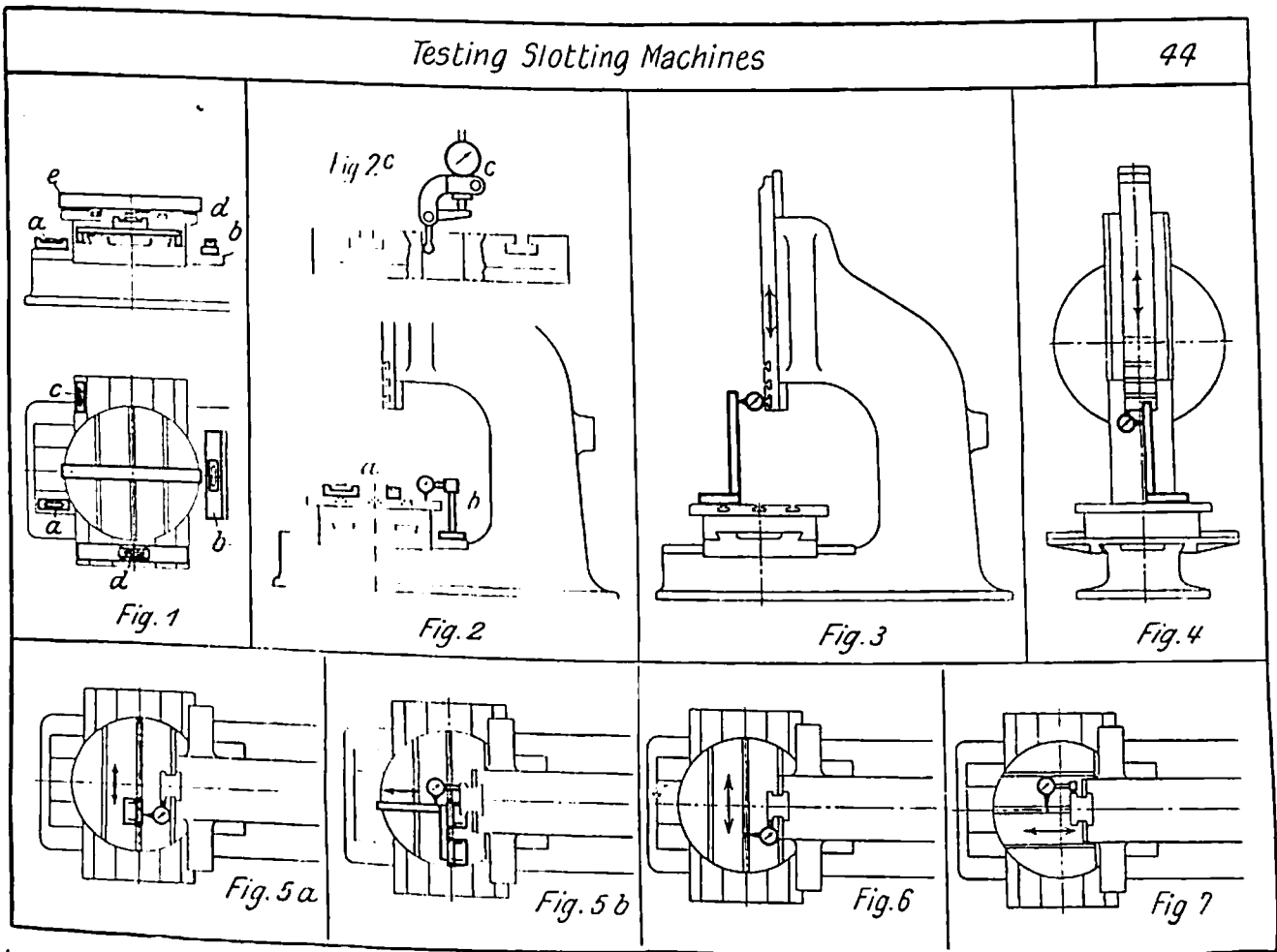

Test Chart for Shaping Machines		No. 43 Chart 3
Test to be Applied	Fig. No.	Permissible Error
Working accuracy of machine: II. Finishing vertical surface of angle plate or prismatic block $H = \frac{1}{2}$ of vertical movement of tool. Length $L$ of block or angle plate = $\frac{1}{2}$ of stroke of ram Finishing surface A B: (a) By lowering tool box vertically from A to B (b) By raising table through distance A B The finished surface A B is perpendicular to top surface of table or of block (Surface of angle plate or block which rests on table must be carefully prepared)	 Fig. 12	0.02 per 300 mm.

Test Chart for Slotting Machines		No. 44 Chart 1
Test to be Applied	Fig. No.	Permissible error mm.
Guides and table: Bed ways for long. slide straight in long. direction	1a	$\pm 0.04$ per 1,000 mm.
Bed ways for long. slide flat or level in transverse direction	1b	$\pm 0.04$ per 1,000 mm.

Test Chart for Slotting Machines		No. 44 Chart 2
Test to be Applied	Fig. No.	Permissible Error
Guides for transverse slide straight in direction at right angles to bed ways	1c	$\pm 0.04$ per 1,000 mm.
Guides for transverse slide flat or level in direction of bed ways	1d	$\pm 0.04$ per 1,000 mm.
Work table flat or level (concave only) . .	1e	0 to 0.02 per 300 mm. dia.
Incline of table in its longitudinal travel	2a	$\pm 0.06$ per 1,000 mm.
Ditto, in its transverse travel . . . .	2a	$\pm 0.06$ per 1,000 mm.
Face of work table for true running . .	2b	0.03 per 300 mm. dia.
Centre hole of table true from 10 in. to 50 in. dia.	2c	0.03 per 300 mm. dia.
Ram: Movement of ram square with work table in plane through centre of column (inclined at lower end towards column)	3	0 to 0.03 per 300 mm.
Ditto, in plane perpendicular to said plane	4	0.02 per 300 mm.
Transverse movement of work table (Fig. 5a) square with its long. movement (Fig. 5b) (Fig. 5a: location of work table from central T-slot) . .	5	0.02 per 300 mm.

For Table of Equivalents in English Measure see page 76

Testing Open-Fronted Power Presses and Punching Machines

51

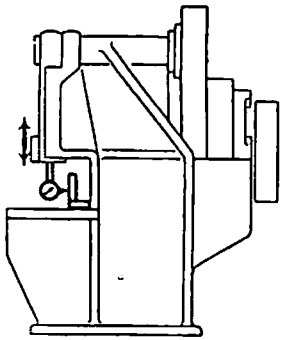

Fig. 1

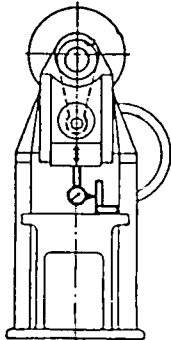

Fig. 2

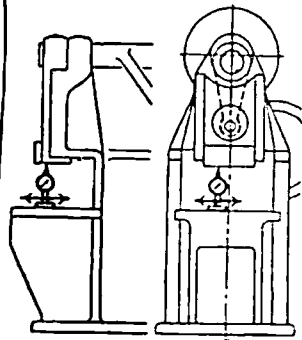

Fig. 3

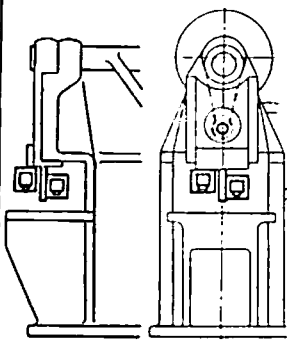

Fig. 4

Test Chart for Open-Fronted Power Presses and Punching Machines No. 51

Test to be Applied	Fig. No.	Permissible Error
Movement of ram or slide square with table in plane through centre of frame (inclined inwards at lower end) For machines up to 50 tons maximum pressure capacity From 50 to 250 tons maximum pressure capacity Over 250 tons maximum pressure capacity	1	mm. 0 to 0.05 per 300 mm. 0 to 0.07 per 300 mm. 0 to 0.10 per 300 mm.
Ditto, in plane perpendicular to plane through centre of frame For machines up to 50 tons maximum pressure capacity From 50 to 250 tons maximum pressure capacity Over 250 tons maximum pressure capacity	2	0.03 per 300 mm. 0.05 per 300 mm. 0.1 per 300 mm.
Bottom surface of ram parallel with table in plane through centre of frame (inclined downwards at outer end) For machines up to 50 tons maximum pressure capacity From 50 to 250 tons maximum pressure capacity Over 250 tons maximum pressure capacity	3a	0 to 0.05 per 300 mm. 0 to 0.07 per 300 mm. 0 to 0.10 per 300 mm.
Bottom surface of ram parallel with table in plane perpendicular to plane through centre of machine: For machines up to 50 tons maximum pressure capacity From 50 to 250 tons maximum pressure capacity Over 250 tons maximum pressure capacity	3b	0.03 per 300 mm. 0.05 per 300 mm. 0.1 per 300 mm.
Hole receiving punch square with bottom surface of ram in plane through centre of frame: For machines up to 50 tons maximum pressure capacity From 50 to 250 tons maximum pressure capacity Over 250 tons maximum pressure capacity	4a	0.03 per 300 mm. 0.05 per 300 mm. 0.1 per 300 mm.
Ditto, in plane perpendicular to plane through centre of machine: For machines up to 50 tons maximum pressure capacity From 50 to 250 tons maximum pressure capacity Over 250 tons maximum pressure capacity	4b	0.03 per 300 mm. 0.05 per 300 mm. 0.1 per 300 mm.

Test Chart for Slotting Machines

No. 44 Chart 3

Test to be Applied	Fig. No.	Permissible Error
T-slots parallel with transverse motion of table in the zero-position of table locked by index pin (for machines with indexing table)	6	mm. 0.02 per 300 mm.
T-slots parallel with long. motion of table in the 90-deg. position of table locked by index pin (for machines with indexing table)	7	0.02 per 300 mm.

Working Accuracy of Slotting Machines

Steel block according to sketch about 100 mm. (4 in.) dia. Plane surfaces A-B-C-D about 50 mm. (2 in.) wide. Cylindrical surfaces remainder.

Fig. No. 8

METHODS	Gauges	Tolerances: Stroke of Machine			
		Less than 350 mm. (14 in.)	From 380 mm. (15 in.) to 700 mm. (28 in.)	Over 700 mm. (28 in.)	
Surface A and B made by longitudinal movement of table	A and B, C and D must be parallel	Micrometer	0.04 mm. per 300 mm.	0.06 mm. per 300 mm.	0.08 mm. per 300 mm.
Surfaces C and D made by transverse movement of table	A, B and C, D, must be perpendicular	Square and slip gauges	0.025 mm. per 300 mm.	0.04 mm. per 300 mm.	0.05 mm. per 300 mm.
Surfaces EEEE made by circular movement of table	Difference between any two diameters of cylinder E	Micrometer	0.04 mm.	0.06 mm.	0.08 mm.
	All surfaces perpendicular to base of block	Square	0.025 mm. per 300 mm.	0.04 mm. per 300 mm.	0.05 mm. per 300 mm.

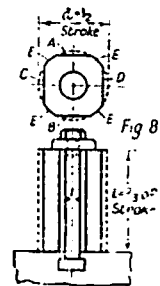

For Table of Equivalents in English Measure see page 41

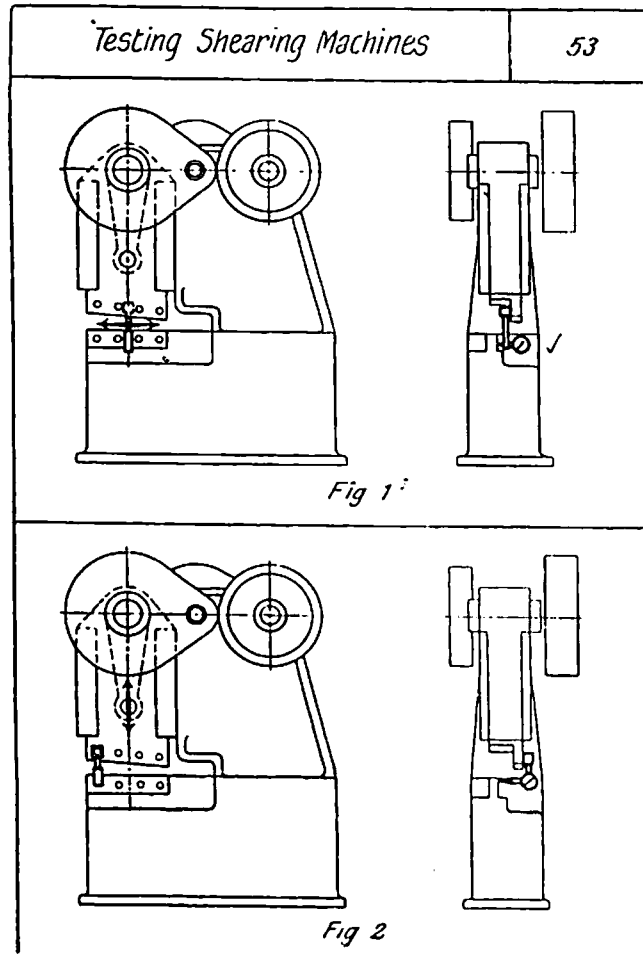
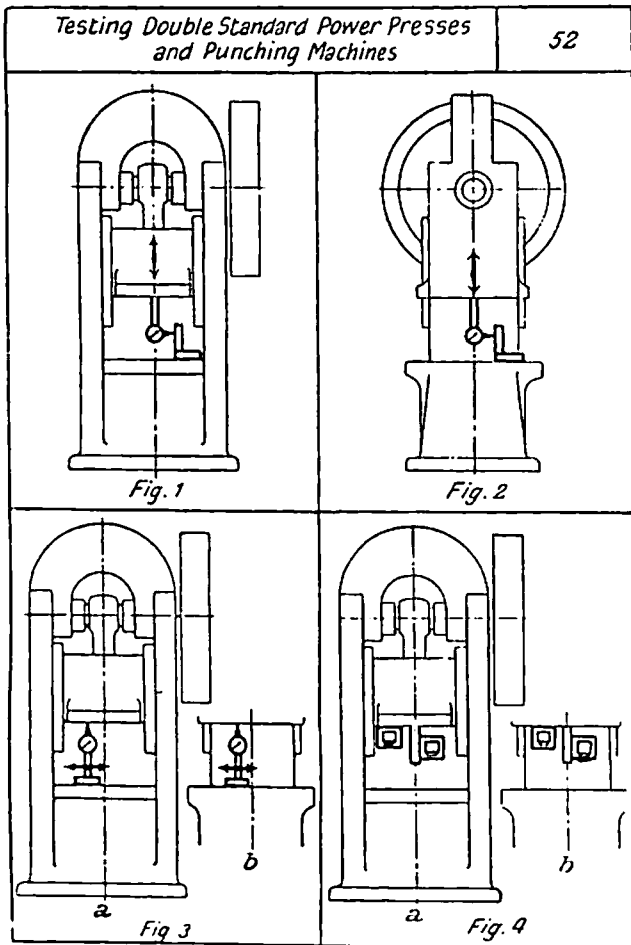

Test Chart for Double Standard Power Presses and Punching Machines		No. 52
Test to be Applied	Fig. No.	Permissible Error
Movement of ram or slide square with table in plane through both standards: For machines up to 50 tons maximum pressure capacity From 50 to 250 tons maximum pressure capacity over 250 tons maximum pressure capacity	1	mm. 0.03 per 300 mm. 0.05 per 300 mm. 0.08 per 300 mm.
Ditto, in plane perpendicular to plane through both standards: For machines up to 50 tons maximum pressure capacity From 50 to 250 tons maximum pressure capacity Over 250 tons maximum pressure capacity	2	0.03 per 300 mm. 0.05 per 300 mm. 0.08 per 300 mm.
Bottom surface of ram parallel with table in plane through both standards: For machines up to 50 tons maximum pressure capacity From 50 to 250 tons maximum pressure capacity Over 250 tons maximum pressure capacity	3a	0.03 per 300 mm. 0.05 per 300 mm. 0.08 per 300 mm.
Ditto, in plane perpendicular to plane through both standards: For machines up to 50 tons maximum pressure capacity From 50 to 250 tons maximum pressure capacity Over 250 tons maximum pressure capacity	3b	0.03 per 300 mm. 0.05 per 300 mm. 0.08 per 300 mm.
Hole receiving punch square with bottom surface of ram in plane through both standards: For machines up to 50 tons maximum pressure capacity From 50 to 250 tons maximum pressure capacity Over 250 tons maximum pressure capacity	4a	0.03 per 300 mm. 0.05 per 300 mm. 0.08 per 300 mm.
Ditto, in plane perpendicular to plane through both standards: For machines up to 50 tons maximum pressure capacity From 50 to 250 tons maximum pressure capacity Over 250 tons maximum pressure capacity	4b	0.03 per 300 mm. 0.05 per 300 mm. 0.08 per 300 mm.

Test Chart for Plate Shearing Machines and Guillotines without Adjustability of Shear Blades for Parallelism		No. 53
Test to be Applied	Fig. No.	Permissible Error
Bearing surfaces of shear blades for parallelism: Maximum deviation on total length of shear blade: For machines with shearing capacity for sheets up to 10 mm. (approximately $\frac{3}{8}$ in.) thick With shearing capacity for sheets up to 30 mm. ( $1\frac{1}{8}$ in.) thick With shearing capacity for sheets over 30 mm. thick	1	mm. 0.1 0.2 0.3
Movement of upper shear blade parallel with bearing surface of the bottom shear blade (with crocodile shears measurement to be taken at extremity of largest lever arm)	2	0.05 per 50 mm.

# ACCEPTANCE TESTS FOR WOODWORKING MACHINES

Acceptance tests for wood-working machines must be drawn up in a manner different from that for acceptance tests for metal-working machines. This is due to the workpiece material, the wood itself. Wood requires very high cutting speeds, which, in metal machining, are employed for grinding operations only, or for light alloys, and these speeds govern the whole design of machine and tool. Since the machine must function without vibration at such high speeds, the cutter spindle must be dynamically balanced and the main bearings suitably designed.

An additional factor which has to be taken into consideration in any scheme of acceptance tests lies in the lack of homogeneity of the wood and its comparative dimensional instability, properties which handicap its exact machining. After machining, the finished shape changes on account of its previous treatment, subsequent treatment and the influence of the atmosphere. If dimensions are to be reasonably maintained, the exterior of the workpiece must, therefore, be protected by varnish or paint as soon as possible after machining.

It is evident that the high degree of accuracy which is usual in metal working is not obtainable, nor called for, in woodworking. Hence acceptance tests for woodworking machines can be comparatively simple and provide for fairly coarse tolerances, partly because woodworking machines are much simpler in design than those for metal working.

It is recommended that woodworking tools be classified into two groups:

- (1) Those with guaranteed accuracy.
- (2) Those without guaranteed accuracy.

In what follows, acceptance tests are established for the ordinary simple machines, such as circular saws, band saws, fret saws, frame saws, planing and thicknessing machines, 4-cutter planing and moulding machines, vertical-spindle moulding machines, chain-cutter mortising machines, and wood turning lathes.

The test values given have been adopted as an outcome of consultation with the leading manufacturers of England, America, Sweden and the Continent.

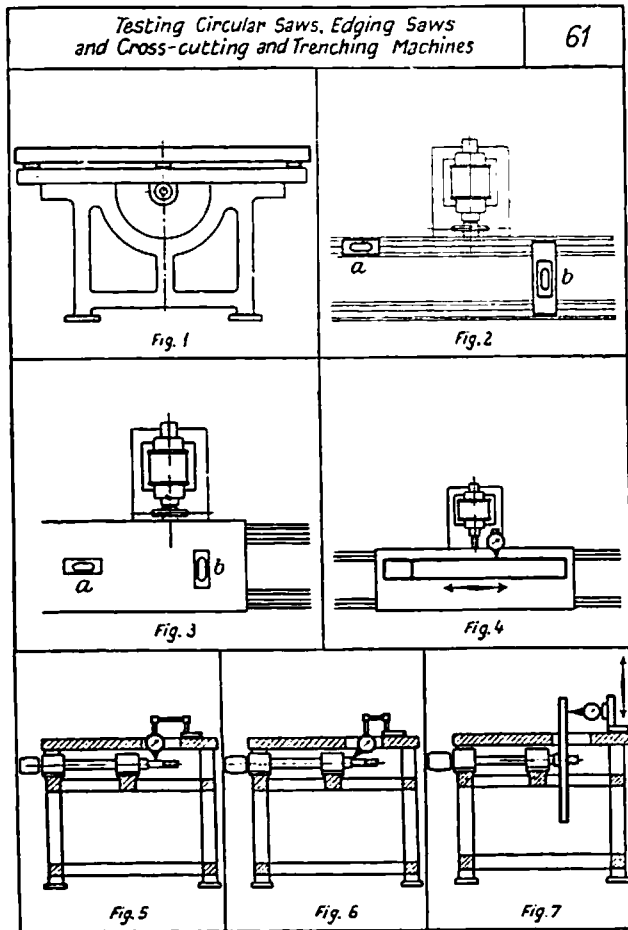

Test Chart for Circular Saws ; Straight-line Edging Saws and Cross Cutting and Trenching Machines		No. 61
Test to be Applied	Fig. No.	Permissible Error
mm.		
Levelling of work table: Table flat longitudinally .. .. .	1	0.2 per 1,000 mm.
Ditto, transversely .. .. .		0.2 per 1,000 mm.
Bed guides and Carriage (edging saws): Bed guideways for the carriage level longitudinally	2a	0.2 per 1,000 mm.
Ditto, transversely .. .. .	2b	0.2 per 1,000 mm.
Table surface of carriage level longitudinally (only for carriage with iron table)	3a	0.2 per 1,000 mm.
Ditto, transversely .. .. .	3b	0.2 per 1,000 mm.
Rise and fall of table in its longitudinal motion	4	0.2 per 1,000 mm.
Saw spindle:		
Spindle runs out of truth .. .. .	5	0.02
Shaft for axial slip .. .. .	6	0.05
Shaft parallel to table surface (measured at a faceplate on the shaft, adjusted for true running)	7	0.2 per 100 mm.
Practical test of the machine at the makers: Machine produces a smooth and even surface		

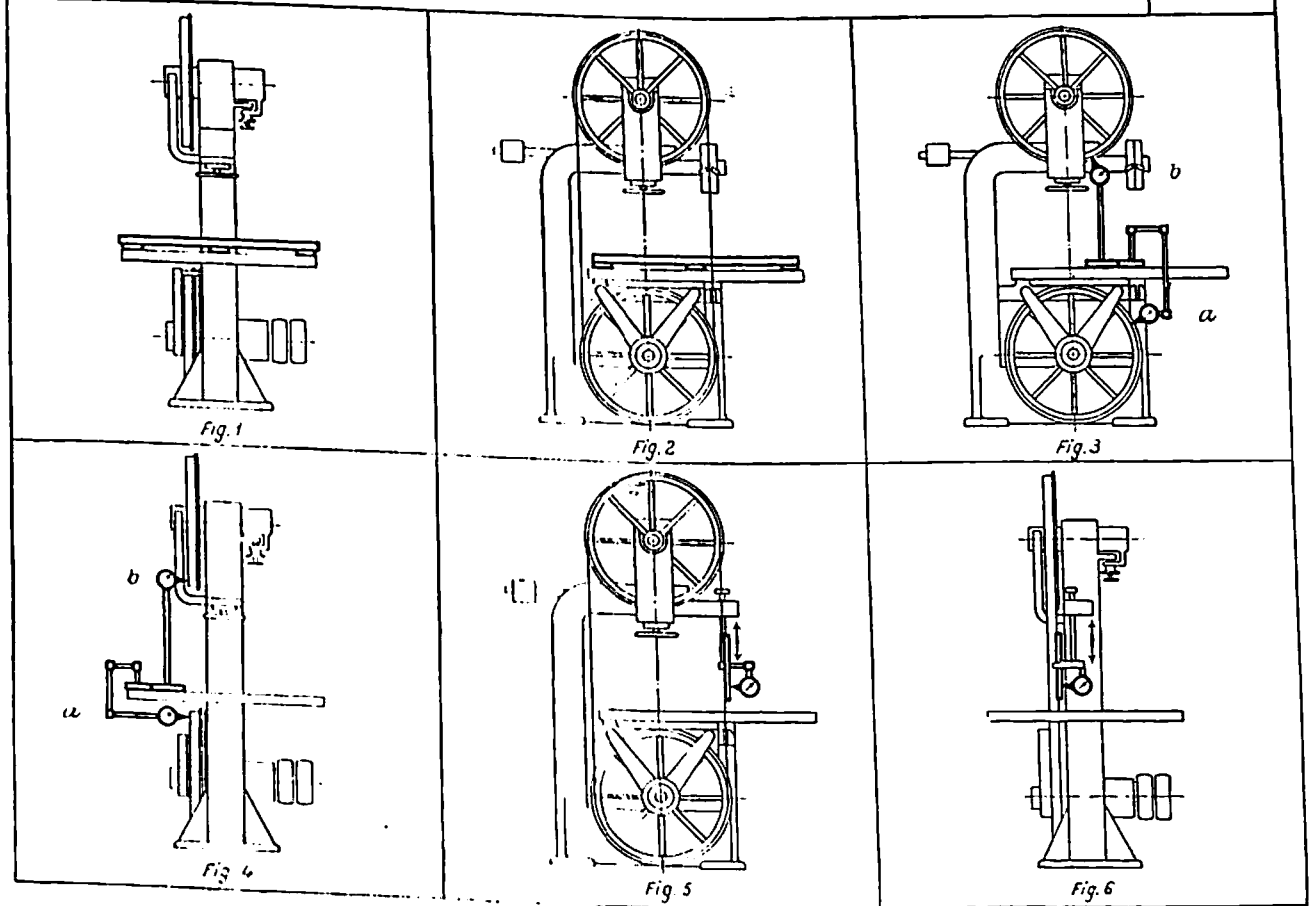

Test Chart for Bandsaws		No. 62 Chart 1
Test to be Applied	Fig. No.	Permissible Error mm.
Table: Table flat longitudinally	1	0.2 per 1,000 mm.
Ditto, transversely	2	0.2 per 1,000 mm.
Guide Pulleys: Lower pulley for true running (concentricity): Up to 1,000 mm. (40 in.) dia. . . . . Over 1,000 mm. (40 in.) dia. . . . .	3a	0.03 0.04
Lower pulley for true running laterally: Up to 1,000 mm. (40 in.) dia. . . . . Over 1,000 mm. (40 in.) dia. . . . .	4a	0.1 0.2
Lower pulley runs true at max. speed (well balanced), i.e. without vibration		
Upper pulley for true running (concentricity): Up to 1,000 mm. (40 in.) dia. . . . . Over 1,000 mm. (40 in.) dia. . . . .	3b	0.03 0.04

Test Chart for Bandsaws		No. 62 Chart 2
Test to be Applied	Fig. No.	Permissible Error mm.
Upper pulley for true running laterally: Up to 1,000 mm. dia. . . . . Over 1,000 mm. dia. . . . .	4b	0.1 0.2
Upper pulley runs true at max. speed (well balanced), i.e. without vibration		
The saw-band runs true after adjustment of pulleys, quietly and without falling off the pulleys		
Displacement of the saw guide with respect to the flat side of the saw. Measurements are taken with the guide in its top and bottom positions, using a straightedge pressed against the flat side of the saw. The guide is clamped in its slide for each reading	5	0.1 per 1,000 mm.
Ditto, with respect to the back edge of the saw	6	0.1 per 1,000 mm.
Practical test of machine at the makers: Machine produces a smooth and even surface		

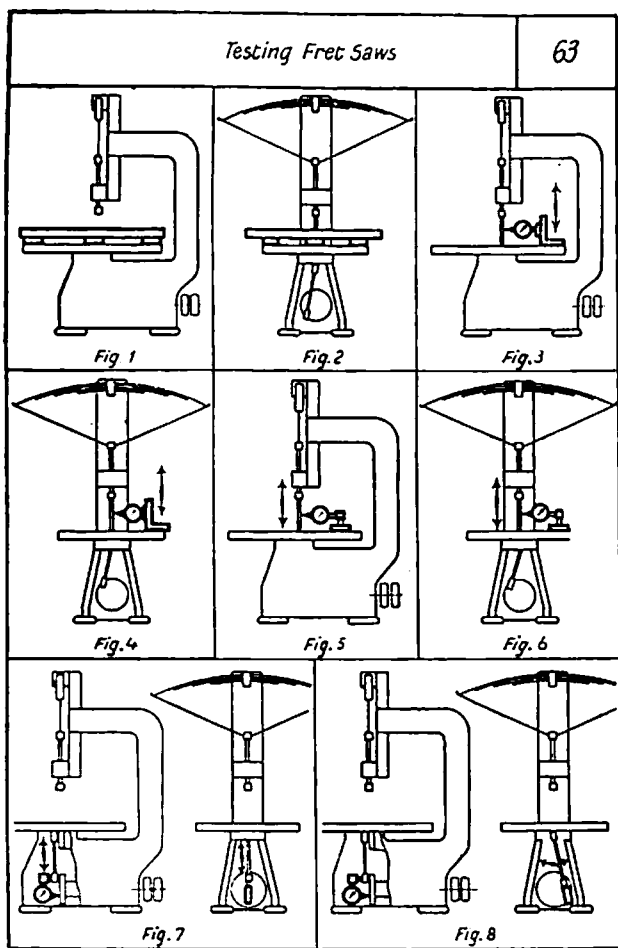

Test Chart for Fret Saws		No. 63
Test to be Applied	Fig. No.	Permissible Error
Table: Table flat longitudinally .. .. .	1	mm. 0.2 per 1,000 mm.
Ditto, transversely .. .. .	2	0.2 per 1,000 mm.
Saw blade perpendicular to table, measured from the back edge. The saw blade may have an inclination towards the front only	3	+0.5 -0 per 100 mm.
Ditto, measured from the flat of the blade (only for machines with non- inclinable table)	4	0.3 per 100 mm.
Displacement of saw in a front and back direction during stroke. The blade may have an inclination to the front only	5	+0.5 -0 per 100 mm.
Ditto, from side to side (only for machines with non-inclinable table)	6	0.3 per 100 mm.
Movement of the lower connecting rod (cross-head) parallel to plane of crank- disc. (The connecting-rod is taken off from the disc and carries the dial gauge)	7	0.2 per 100 mm.
Oscillating movement of connecting rod about pivot of cross-head parallel to the crank-disc. (The connecting rod is taken off from the disc and carries the dial gauge)	8	0.2 per 100 mm.
Practical test of machine at the makers: Machine produces a smooth and even surface		

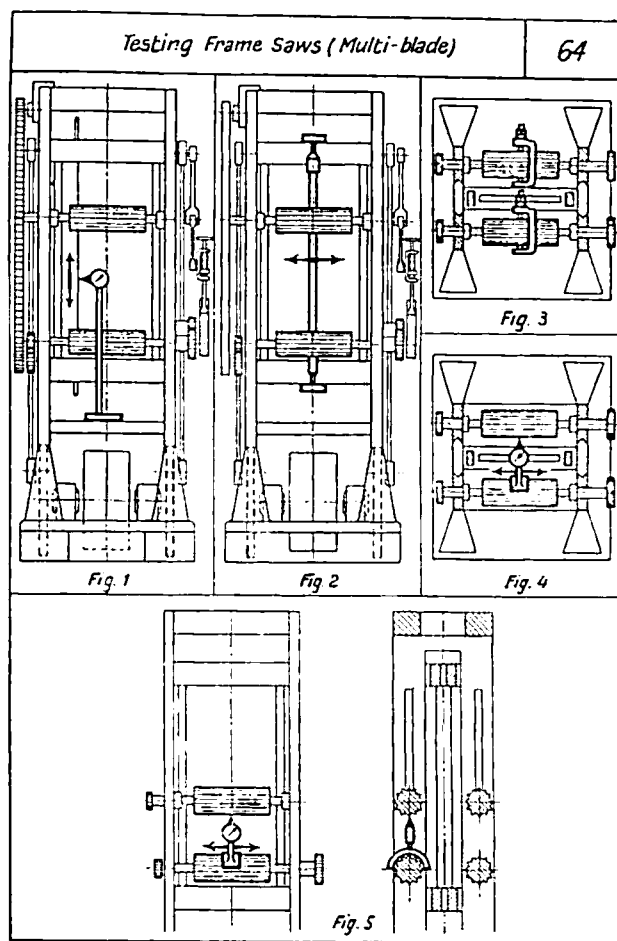

Test Chart for Frame Saws (Multi-blade)		No. 64
Test to be Applied	Fig. No.	Permissible Error
Column Frame: Vertically set blades move in a straight line	1	mm. 0.1 per 300 mm.
Setting faces of saw-buckles are parallel to each other	2	0.2 per 300 mm.
Feed Rollers: Driven feed rollers cylindrical and of same diameter	3	0.3
Upper rollers parallel to each other ..	4	0.4 per 300 mm.
Lower rollers parallel to each other ..	4	0.4 per 300 mm.
Upper rollers parallel to lower pairs (measurements taken with upper rollers at different heights)	5	0.4 per 300 mm.
Practical test of machine at the makers: The boards cut are parallel and straight, with smooth and even surfaces		

WHEELS INDIA LIMITED  
 Plant Engineering Dept

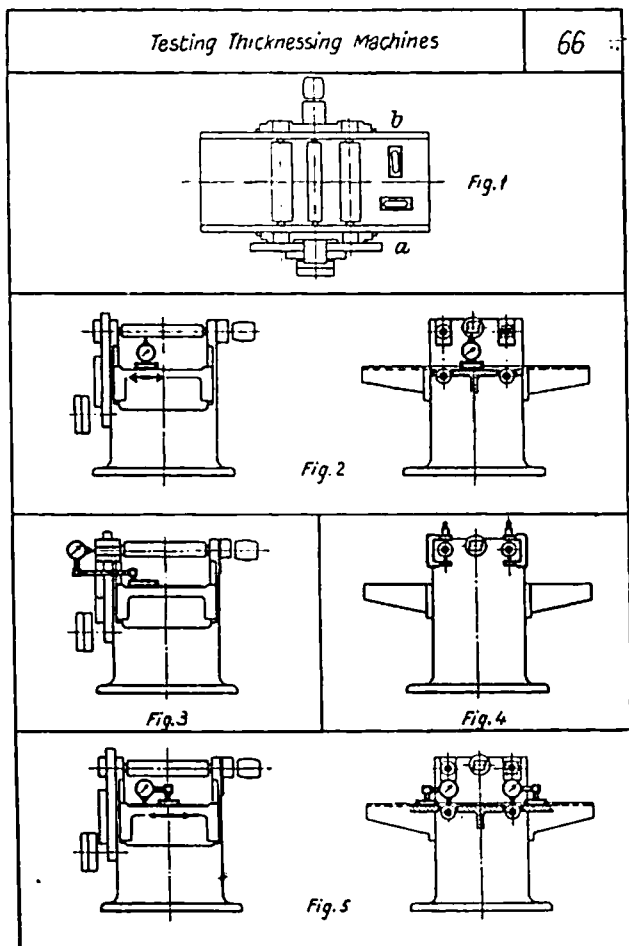
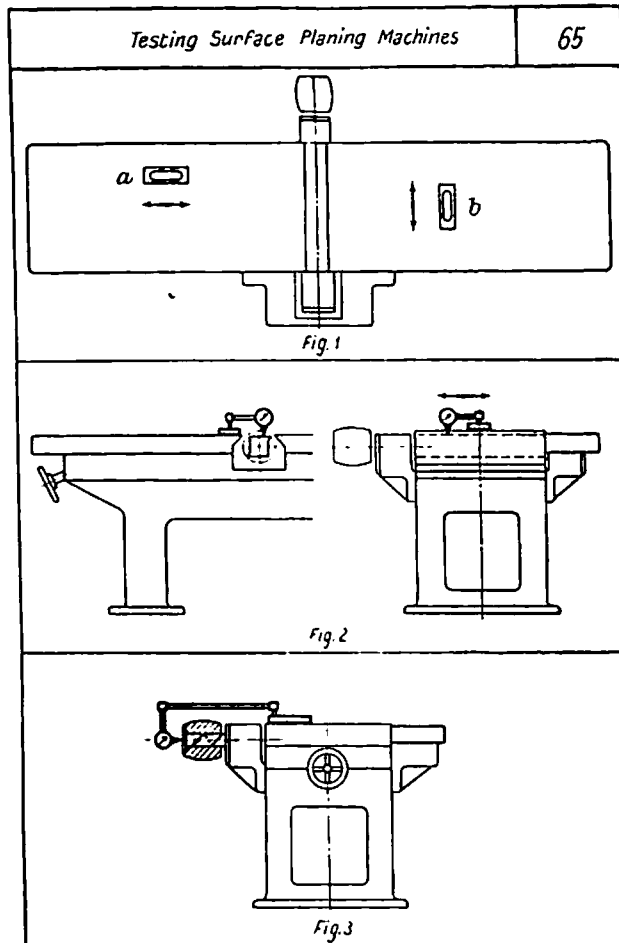

<b>Test Chart for Surface Planing Machines</b>		No. 65
Test to be Applied	Fig. No.	Permissible Error
Table:		
Table flat and level longitudinally ..	1a	mm. 0.2 per 1,000 mm.
Ditto, transversely .. .. .	1b	0.2 per 1,000 mm.
Cutter-block Spindle:		
Setting faces of cutters are parallel to table surface	2	0.1 per 300 mm.
Cutter-block spindle for axial slip ..	3	0.05
Cutter-block spindle is satisfactorily balanced : runs without vibration at maximum speed		
Practical test of machine at the makers: Machine planes a smooth and even surface		

<b>Test Chart for Thicknessing Machine</b>		No. 66
Test to be Applied	Fig. No.	Permissible Error
Table:		
Table flat and level longitudinally ...	1a	mm. 0.2 per 1,000 mm.
Ditto, transversely .. .. .	1b	0.2 per 1,000 mm.
Cutter-block Spindle:		
Setting faces of cutters are parallel to table surface	2	0.1 per 300 mm.
Cutter spindle for axial slip .. ..	3	0.05
Cutter spindle is satisfactorily balanced: runs without vibration at full speed		
Feed Rollers		
Driven feed rollers cylindrical and of equal diameter	4	0.1
Lower rollers parallel to table surface ..	5	0.1 per 300 mm.
Practical test of machine at the makers: Machine planes a smooth and even surface		
1. The boards are parallel longitudinally (measured directly after planing)		0.2 mm. per total length of board 0.1 per 300 mm.
2. Parallel transversely (measured directly after planing) .. ..		



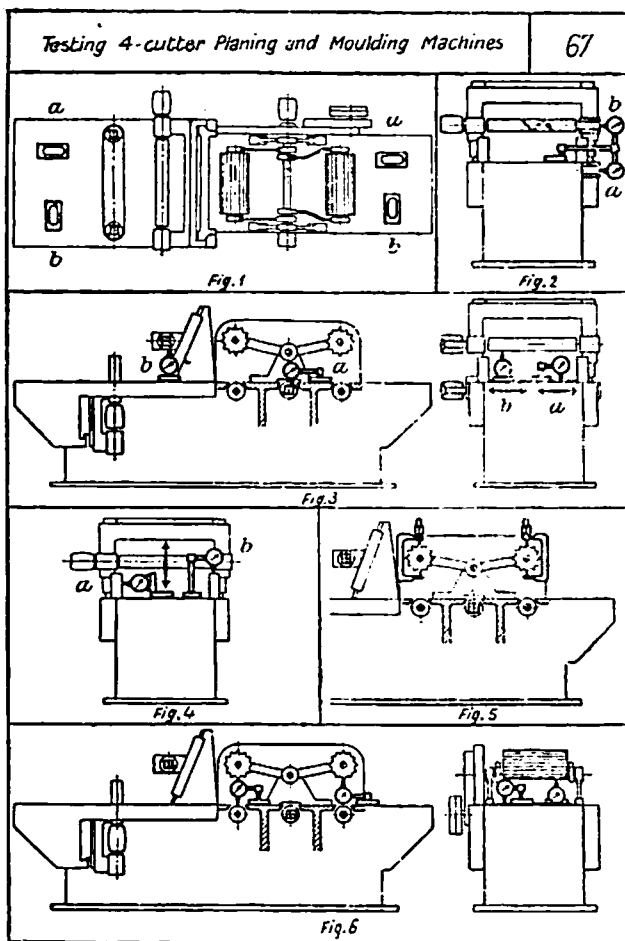

Test Chart for 4-Cutter Planing and Moulding Machines		No. 67
Test to be Applied	Fig. No.	Permissible Error
Table:		
Table flat and even longitudinally ..	1a	mm. 0.2 per 1,000 mm.
Ditto, transversely .. .. .	1b	0.2 per 1,000 mm.
Cutter-block Spindles:		
Setting faces of lower cutter spindle are parallel to table surface ..	3a	0.1 per 300 mm.
Lower cutter spindle is well balanced: runs without vibration at max. speed.		
Lower cutter spindle for axial slip ..	2a	0.05
Setting faces of upper cutter spindle are parallel to table surface ..	3b	0.1 per 300 mm.
Upper cutter spindle is well balanced: runs without vibration at max. speed		
Upper cutter spindle for axial slip ..	2b	0.05
Setting faces of side-cutter spindles are perpendicular to table surface ..	4a	0.05 per 100 mm.
Side cutter spindles are well balanced: run without vibration at max. speed		
Side cutter spindles for axial slip ..	4b	0.05
Feed Rollers:		
Driven feed rollers cylindrical and of equal diameter	5	0.1
Feed rollers parallel to table surface ..	6	0.1 per 300 mm.
Practical test of machine at the makers: Machine planes all surfaces smooth and even:		
1. The workpiece is parallel longitudinally		0.2 per total length of board
2. Ditto transversely .. .. .		0.1 per 300 mm.
3. Width is uniform .. .. .		0.2 per total length of board

**Test Chart for Vertical Spindle Moulding Machines** No. 68

Test to be Applied	Fig. No.	Permissible Error
Table:		
Table flat and level longitudinally ..	1	mm. 0.2 per 1,000 mm.
Ditto, transversely .. .. .		0.2 per 1,000 mm.
Cutter Spindle:		
Internal taper of cutter spindle runs true:		
1. Nearest to spindle nose .. .. .	2	0.03
2. At a distance of 300 mm. (12 in.) ..	3	0.05
Cutter spindle for axial slip .. .. .	4	0.05
Work table square with cutter spindle in plane through longitudinal axis of machine (turn-round method) ..	5	0.01 per 100 mm.
Cutter spindle is well balanced: runs without vibration at maximum speed		
Bore of arm bracket for spindle steady aligned with cutter spindle in two planes perpendicular to each other	6	0.05 per 300 mm.
Practical test of machine at the makers: The moulded surfaces are smooth and even		

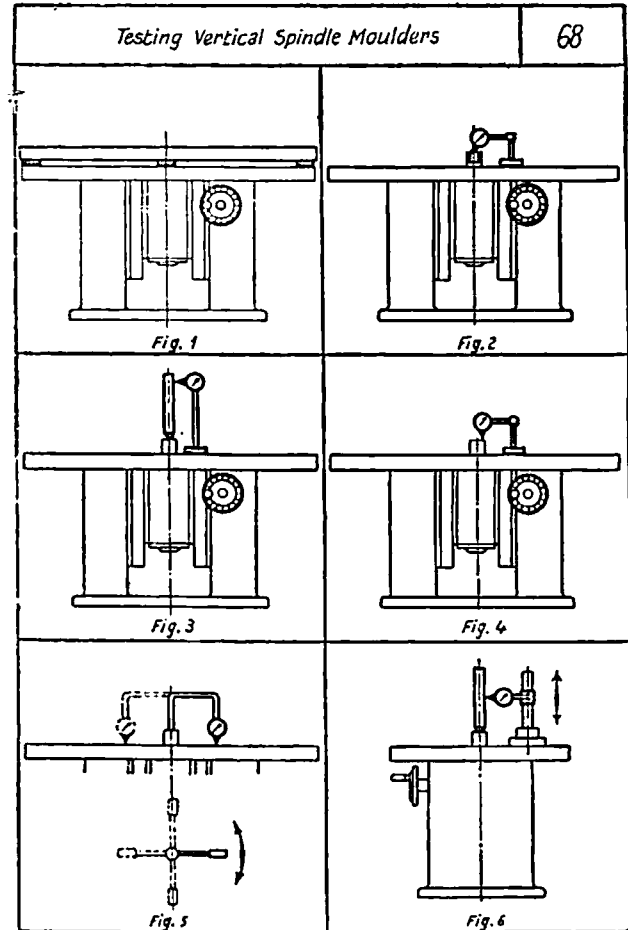

Test Chart for Chain Mortising Machines		No. 69
Test to be Applied	Fig. No.	Permissible Error
		mm.
Carriage: Guide of chain perpendicular to table in plane through longitudinal axis of table	1	0.05 per 100 mm.
Ditto, transversely .. .. .	2	0.05 per 100 mm.
Movement of tool carriage perpendicular to table surface in the longitudinal plane	3	0.05 per 100 mm.
Ditto, in the transverse plane .. ..	4	0.05 per 100 mm.
Table: Table flat and level longitudinally ..	5	0.1 per 300 mm.
Ditto, transversely .. .. .	6	0.1 per 300 mm.
Table fence perpendicular to table ..	7	0.1 per 100 mm.
Knee: Guideways of knee perpendicular to table longitudinally .. .. .	8	0.2 per 300 mm.
Ditto, transversely .. .. .	9	0.2 per 300 mm.
Practical test of machine at the makers: Machine cuts the surfaces of the mortise smooth and clean		

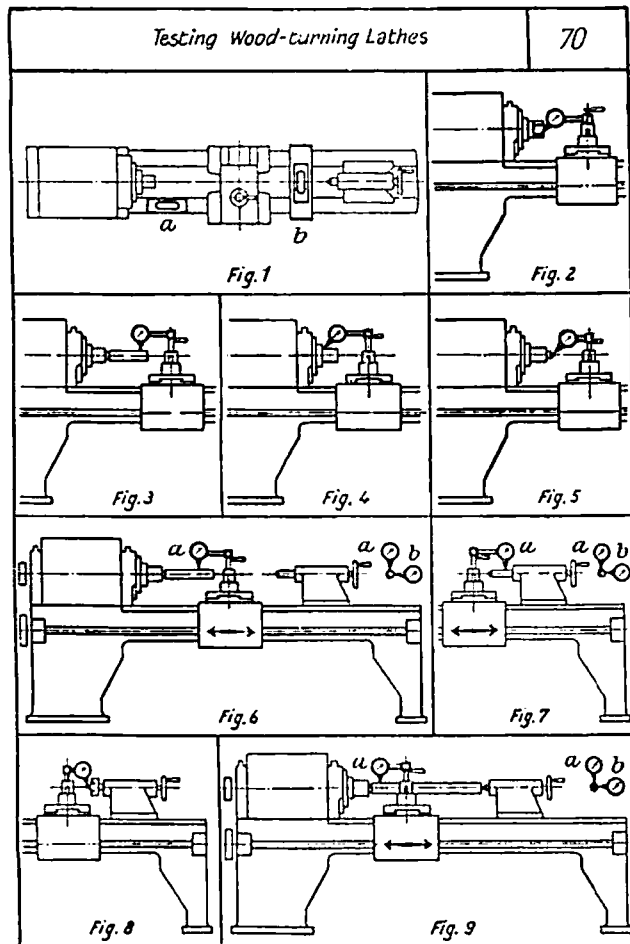
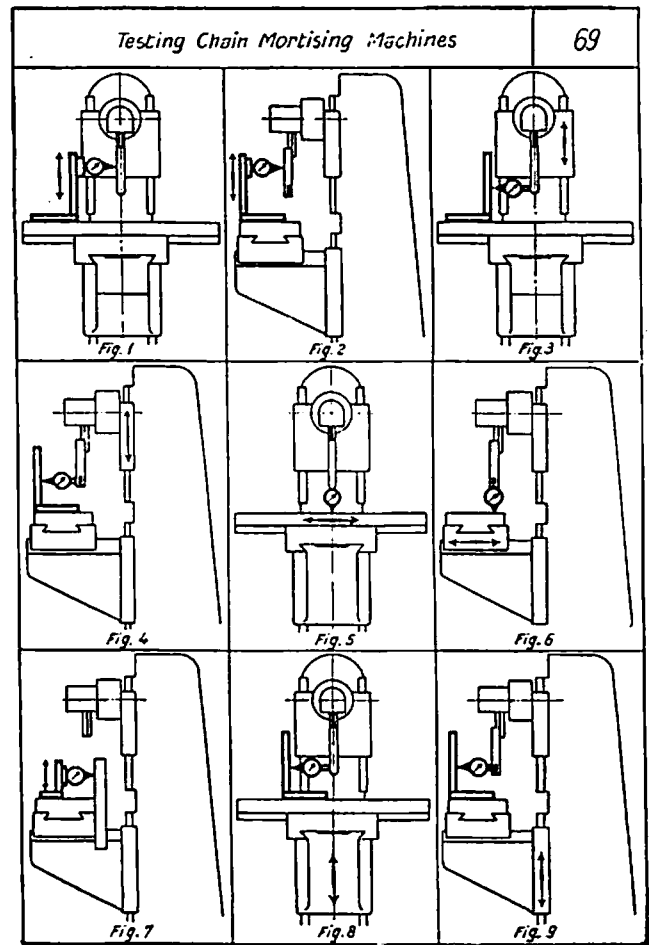

Test Chart for Wood Turning Lathes		No. 70
Test to be Applied	Fig. No.	Permissible Error
		mm.
Bed: Bed level in longitudinal direction ..	1a	0.2 per 1,000 mm.
Ditto, transverse direction .. .. .	1b	0.2 per 1,000 mm.
Headstock: Taper of work spindle runs true: 1. Nearest spindle nose .. .. .	2	0.03
2. At a distance of 300 mm. .. ..	3	0.05
Sleeve shoulder for axial slip .. ..	4	0.05
Centre point for true running .. ..	5	0.1
Work spindle parallel with bed in the vertical plane	6a	0.2 per 300 mm.
Ditto, in the horizontal plane .. .. .	6b	0.2 per 300 mm.
Tailstock: Tailstock sleeve parallel with bed in the vertical plane	7a	0.1 per 100 mm.
Ditto, in the horizontal plane .. .. .	7b	0.1 per 100 mm.
Tailstock centre runs true (for rotating centres only)	8	0.1
Axis of centres (mandrel between centres) parallel with bed: 1. In vertical plane .. .. .	9a	0.2
2. In horizontal plane .. .. .	9b	0.1
Practical test of machine at the makers: Lathe produces a workpiece that is round within		0.1
Lathe turns cylindrically (for machines with clamped tool only)		0.1 per 200 mm.
Lathe faces (hollow only), for machines with compound rest		0.1 per 300 mm.